

FS

**FLEXIBLE SYSTEM SERIES
&
UNIT SERIES**



FLEXIBLE
SYSTEM

FS

Faster and Smoother . . . **FS**



Maximum speed 1500mm/sec *1
High Speed, Long Stroke Actuator
FS Actuator (Flexible Systems)



The FS series actuator was designed for light work, and high speed positioning. The FS module units, together with FS profile modules provide a highly flexible system capable of adapting to a wide variety of different applications. The FS series consists of individual FS modules as well as pre-assembled systems.

Its simple and streamline, yet solid design won the FS series the good design award (G mark) for 1990 in the industrial machinery division which is given by Japan's Ministry of International Trade and Industry (MITI) (No. 90L0968).

(Models selected for the award were FS-11NM-400, 500, 600)

Features

1. Flexible work stations can be constructed at low cost by simply combining actuator modules, guide modules, and profile modules. A greater variety of configurations are available than what was possible with the earlier actuators.
2. A wide variety of gantry and cantilever type configurations are possible, and long stroke, single-axis type systems are well suited for use in high speed loading and unloading applications.
3. The timing belt enables the FS series to perform with minimal noise at high speeds. This high speed capability, particularly when combined with high acceleration, allows for short cycle times in an automated work station.

*1: With an ISAC motor, the maximum speed is 1250mm/sec.



FS SERIES

The FS Series Features:

1. Long Stroke: Maximum 2500mm
 2. Maximum Speed: 1,500mm/sec, tact time improves considerably if work is lightweight. (*)
 3. A wide variety of configurations are possible by simply combining IA Actuator, Guide Rail and Profile Modules.
 4. Small sectional dimensions make the FS Series ideal in limited space situations.
 5. Low running noise.
 6. D1 and D2 versions (available as options) have longer sliders than the standard FS actuator and come with a dust prevention stainless steel sheet.
- * With an ISAC motor, the maximum speed is 1250mm/sec.

IA-FS-11NM-100-600-AC-D1

1 2 3 4 5 6 7 8 9

1 Intelligent Actuator Products Group

2 Series

FS: Flexible Series

3 Guide Block Type

- 11: Single Guide Block
12: Double Guide Block

4 Shape

- N: Narrow Type (60W, 100W)
W: Wide Type (100W, 200W)

5 Structure

- M: Actuator Module
O: Guide Module

6 Power

- 0: Without Motor
60W: 60W Servo Motor
100W: 100W Servo Motor
200W: 200W Servo Motor

7 Stroke Range

- N Type: 300 ~ 1000mm (11.8" ~ 39.4")
W Type: 300 ~ 2500mm (11.8" ~ 98.4")

8 Motor Type

- DC (or no indicator): DC motor
AC: AC motor

9 Options

- D1: Slider Length Equal to 2 standard FS Sliders
D2: Slider Length Equal to D1 + 100mm

Basic Combination Example

■ Single Axis System

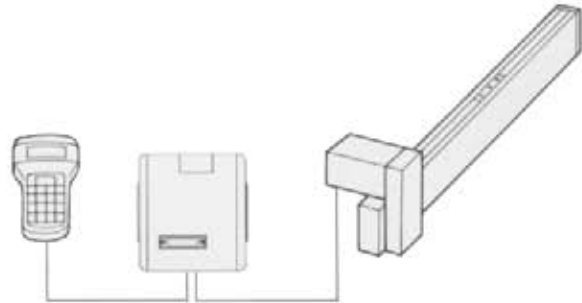

■ System with Two (2) Single-Axis Controllers

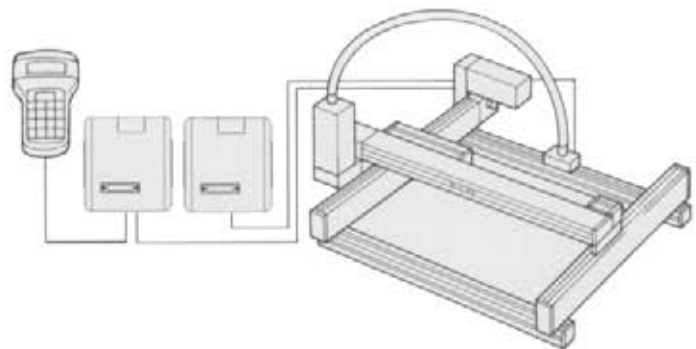

■ System with Multi-Axis SEL Controller

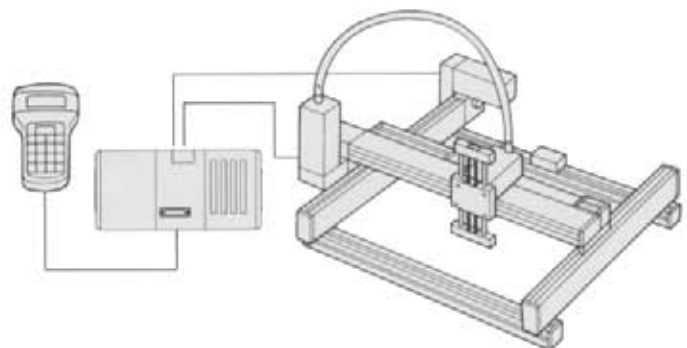

FS Series Overview

The FS Series is broadly classified into two product categories: FS Modules (single unit) listed in the table below and FS Units (assembled FS modules).

FS Modules are either a narrow frame or wide frame type and consist of a single guide type actuator module connected to a 60W, 100W, or 200W AC servo motor and a single extruded guide module. With the FS Series actuators, generally you would purchase the individual FS Modules to construct one of the three configuration types, Single-Axis Table, Gantry or Cantilever, listed for the FS Units.

However, depending on your particular application, you may find it easier to purchase the pre-assembled FS Units. Your FS Unit can be customized according to your specifications and drawings (stroke length, available space, payload, speed...etc.).

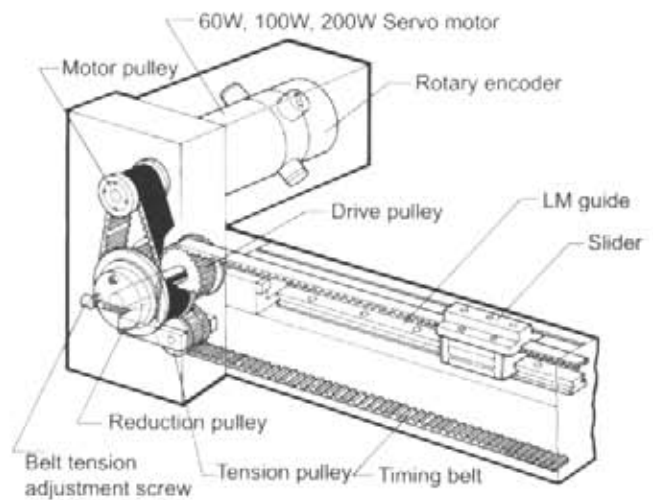

■ FS Series

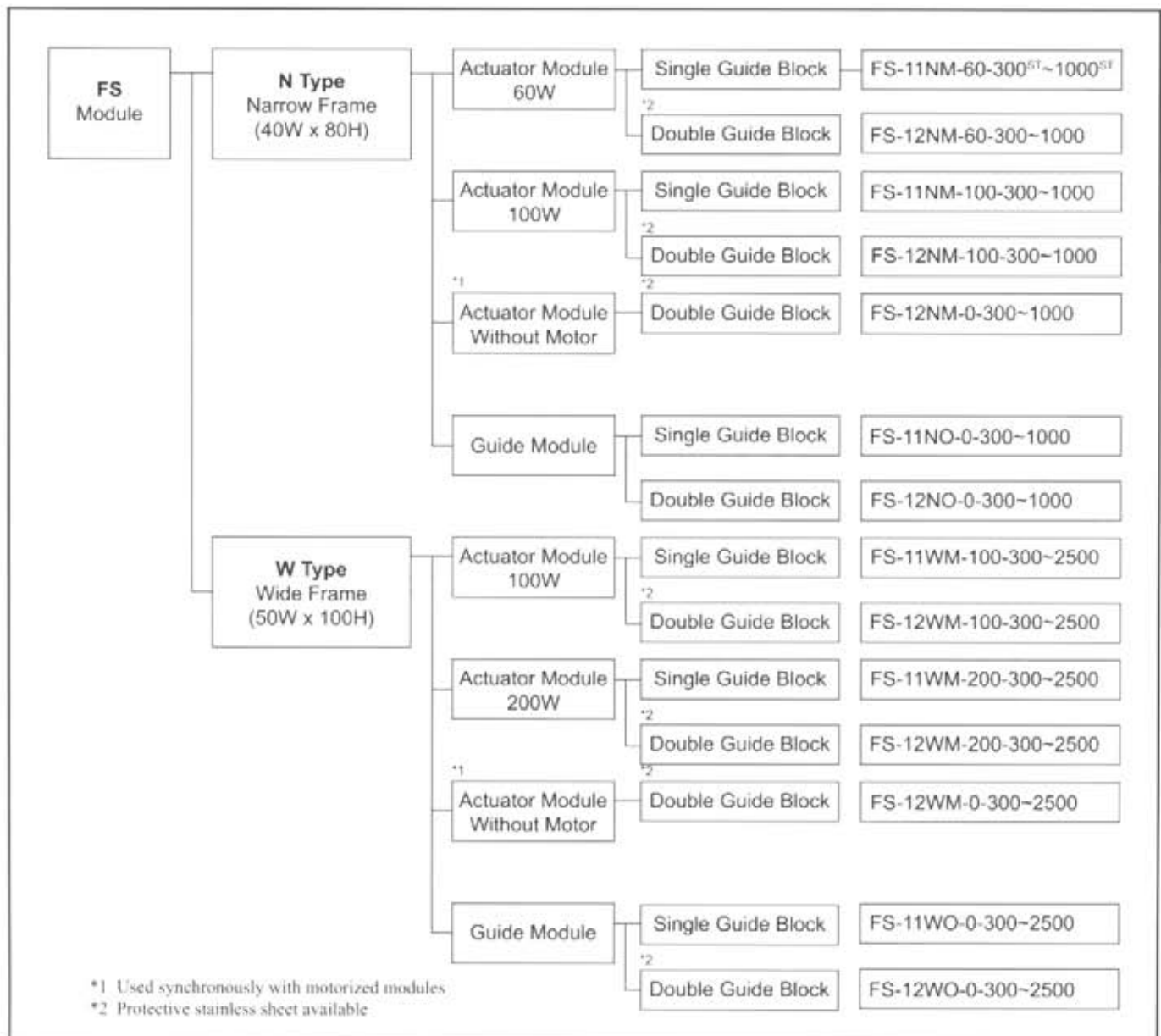

NM Series Standard Specifications and Mechanical Drawing

FS-11NM-100-60

Stroke (mm)	300	400	500	600	700	800	900	1000
Weight (kg)	5.0	5.4	5.8	6.2	6.6	7.0	7.4	7.8

FS-12NM-100-60

Stroke (mm)	300	400	500	600	700	800	900	1000
Weight (kg)	5.7	6.0	6.5	6.9	7.3	7.7	8.1	8.5

Model		FS-11NM-100-60	FS-12NM-100-60
Rated motor power	W	100 (60)	
Rated speed	mm/sec	1250	
Rated thrust	N[kgf]	49 (29) [5 (3)]	
Repeatability	mm	±0.08	
Motor		AC/DC servo motor (100W only for AC)	
Encoder		Attached to motor	
Actuating medium		Timing belt 3M: Width 15mm, Backlash 0.1mm or less	
Linear guide		Linear motion guide: SR-15W Linear motion block (1 for 11NM, 2 for 12NM)	
Motor/belt connection		Reduction ratio by timing belt: 1/2.4	
Base		Extruded aluminum (A6063S-T5) White alumite treatment	
Maximum speed	mm/sec	1500 (1250 when ISAC motor is used)	
Maximum thrust (*1)	N[kgf]	98(58) [10(6)]	
Horizontal payload (*2,3)	kg	3 (2)	15 (9) [11(7) if stroke is 700,800; 9 (5) if stroke is 900, 1000]
Static load (*2,4)	N[kgf]	588 [60]	1176 [120]
Load moment (*5)	N*m[kgf*m]	Ma: 2.9[0.3] Mb: 2.9[0.3] Mc: 4.5[0.46]	Slides together: Ma: 20.5[2.1] Mb: 18.6 [1.9] Mc: 9.1[0.93] Slides 60mm apart: Ma: 78.4[8] Mb: 70.5[7.2] Mc: 9.1[0.93]
Overhang load length L (*5)	mm	200	500 (slides together) 800 (slides 60mm apart)

() = 60W

- *1 Allowable value for 10 seconds at a speed of 10 mm/sec.
- *2 Load uniformly distributed on slider. Base affixed to a flat, strong frame.
- *3 When accelerating to 1250mm/sec at 1G (9800mm/sec²) (FS-11NM-100-60)
When accelerating to 1250mm/sec at 0.3G (2940mm/sec²) (FS-12NM-100-60)
- *4 Value when load moment is not added. Static load is the maximum value when load is added and differs from the payload.
- *5 See figures at right. Moment caused by static load not to exceed allowable load moment. If there is moment in the Mc direction, we recommend using a guide rail (FS-11NO or 12NO) with the actuator.

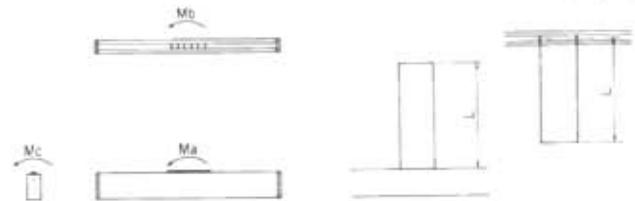

SE - Stroke End
ME - Mechanical End
Dimensions for 60W in ()
*60mm for 11NM

T slot cross section

FS-11NM-100-60

Stroke	300	400	500	600	700	800	900	1000
A	604	704	804	904	1004	1104	1204	1304
B	480	580	680	780	880	980	1080	1180
C	300	400	500	600	700	800	900	1000
D	360	460	560	660	760	860	960	1060

FS-12NM-100-60

Stroke	300	400	500	600	700	800	900	1000
A	704	804	904	1004	1104	1204	1304	1404
B	580	680	780	880	980	1080	1180	1280
C	340	440	540	640	740	840	940	1040
D	460	560	660	760	860	960	1060	1160

NO Series Standard Specifications and Mechanical Drawing

FS-11NO-0

Stroke (mm)	300	400	500	600	700	800	900	1000
Weight (kg)	2.4	2.8	3.2	3.6	4.1	4.4	4.8	5.2

FS-12NO-0

Stroke (mm)	300	400	500	600	700	800	900	1000
Weight (kg)	3.1	3.5	3.9	4.3	4.8	5.1	5.5	5.9

Model		FS-11NO-0	FS-12NO-0
Rated speed	mm/sec	1250	
Linear guide		Linear motion guide: SR-15W Linear motion block (1 for 11NO, 2 for 12NO)	
Base		Extruded aluminum (A6063S-T5) White alumite treatment	
Maximum speed	mm/sec	1500 (1250 when ISAC motor is used)	
Static load (*1, 2)	N[kgf]	588 [60]	1176 [120]
Load moment (*3)	Nim[kgfm]	Ma: 2.9[0.3] Mb: 2.9[0.3] Mc: 4.5[0.46]	Slides together: Ma: 20.5[2.1] Mb: 18.6 [1.9] Mc: 9.1[0.93] Slides 60mm apart: Ma: 78.4[18] Mb: 70.5[7.2] Mc: 9.1[0.93]
Overhang load length L (*3)	mm	200	500 (slides together) 800 (slides 60mm apart)

- *1 Load uniformly distributed on slider. Base affixed to a flat, strong frame.
- *2 Value when load moment is not added. Static load is the maximum value when load is added and differs from the payload.
- *3 See figures at right. Moment caused by static load not to exceed allowable load moment. If there is moment in the Mc direction, we recommend using a guide rail (FS-11NO or 12NO) with the actuator.

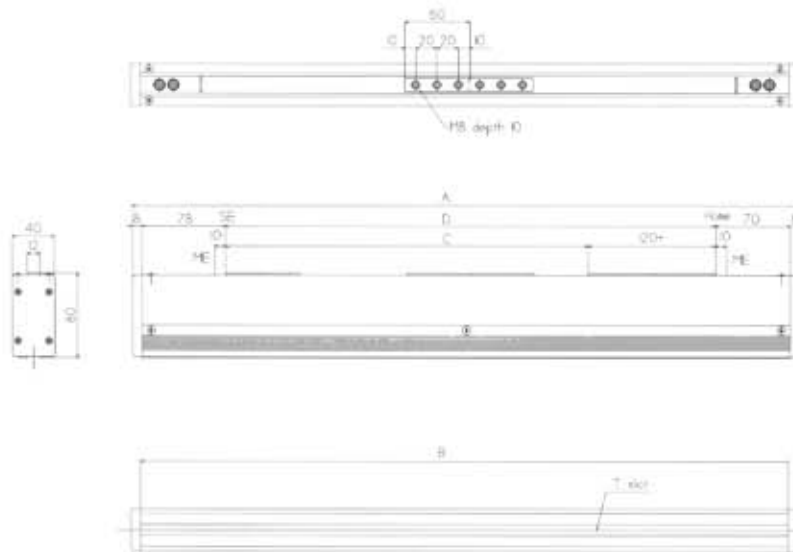
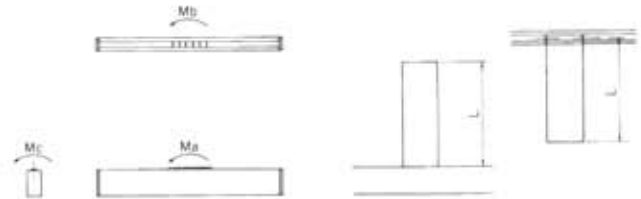

*60mm for 11NO

T slot cross section

FS-11NO-0

Stroke	300	400	500	600	700	800	900	1000
A	524	624	724	824	924	1024	1124	1224
B	508	608	708	808	908	1008	1108	1208
C	300	400	500	600	700	800	900	1000
D	360	460	560	660	760	860	960	1060

FS-12NO-0

Stroke	300	400	500	600	700	800	900	1000
A	624	724	824	924	1024	1124	1224	1324
B	608	708	808	908	1008	1108	1208	1308
C	340	440	540	640	740	840	940	1040
D	460	560	660	760	860	960	1060	1160

WM Series Standard Specifications and Mechanical Drawing

FS-11WM-200-100

Stroke (mm)	300	400	600	800	1000	1500	2000	2500
Weight (kg)	9.8	10.4	11.6	12.8	14.0	17.0	20.0	23.0

(For 100W, reduce by 1.1kg)

FS-12WM-200-100

Stroke (mm)	300	400	600	800	1000	1500	2000	2500
Weight (kg)	11.0	11.6	12.8	14.0	15.2	18.2	21.2	24.2

(For 100W, reduce by 1.1kg)

Model		FS-11WM-200-100		FS-12WM-200-100	
Rated motor power	W	200 (100)			
Rated speed	mm/sec	1250			
Rated thrust	N[kgf]	98 (49) [10 (5)]			
Repeatability	mm	±0.08			
Motor		AC/DC servo motor			
Encoder		Attached to motor			
Actuating medium		Timing belt 5M: Width 20mm, Backlash 0.1mm or less			
Linear guide		Linear motion guide: SR-20W Linear motion block (1 for 11WM, 2 for 12WM)			
Motor/belt connection		Reduction ratio by timing belt: 1/3.2			
Base		Extruded aluminum (A6063S-T5) White alumite treatment			
Maximum speed	mm/sec	1500 (1250 when ISAC motor is used)			
Maximum thrust (*1)	N[kgf]	196(98) [20(10)]			
Horizontal payload (*2,3)	kg	6 (3)	30 (15) [22(11) if stroke is 1600-2000 18(9) if stroke is 2100-2500]		
Static load (*2,4)	N[kgf]	1176 [120]	1960 [200]		
Load moment (*5)	N·m[kgf·m]	Ma: 4.4[0.45] Mb: 3.9[0.4] Mc: 5.8[0.6]	Slides together: Ma: 27.4[2.8] Mb: 25.4[2.6] Mc: 11.7[1.2] Slides 60mm apart: Ma: 107[11] Mb: 98[10] Mc: 11.7[1.2]		
Overhang load length L (*5)	mm	240	600 (slides together) 950 (slides 70mm apart)		

*() = 100W

- *1 Allowable value for 10 seconds at a speed of 10 mm/sec.
- *2 Load uniformly distributed on slider. Base affixed to a flat, strong frame.
- *3 When accelerating to 1250mm/sec at 1G (9800mm/sec²) (FS-11NM-100-60)
When accelerating to 1250mm/sec at 0.3G (2940mm/sec²) (FS-12NM-100-60)
- *4 Value when load moment is not added. Static load is the maximum value when load is added and differs from the payload.
- *5 See figures at right. Moment caused by static load not to exceed allowable load moment. If there is moment in the Mc direction, we recommend using a guide rail (FS-11NO or 12NO) with the actuator.



FS-11WM-200-100

Stroke	300	400	600	800	1000	1500	2000	2500
A	661	761	961	1911	1361	1861	2361	2861
B	490	590	790	990	1190	1690	2190	2690
C	300	400	600	800	1000	1500	2000	2500
D	370	470	670	870	1070	1570	2070	2570

Stroke Increment is 100mm

FS-12WM-200-100

Stroke	300	400	600	800	1000	1500	2000	2500
A	761	861	1061	1261	1461	1961	2461	2961
B	590	690	890	1090	1290	1790	2290	2790
C	330	430	630	830	1030	1530	2030	2530
D	470	570	770	970	1170	1670	2170	2670

Stroke Increment is 100mm

SE = Stroke End
ME = Mechanical End
*70mm for 11WM

T slot cross section

WM Series Standard Specifications and Mechanical Drawing

FS-11WO-0

Stroke (mm)	300	400	600	800	1000	1500	2000	2500
Weight (kg)	4.9	5.6	6.7	8.3	9.6	12.9	16.3	19.6

FS-12WO-0

Stroke (mm)	300	400	600	800	1000	1500	2000	2500
Weight (kg)	5.6	6.2	7.6	8.9	10.2	13.6	16.9	20.3

Model		FS-11WO-0	FS-12WO-0
Rated speed	mm/sec	1250	
Linear guide		Linear motion guide: SR-20W Linear motion block (1 for 11WO, 2 for 12WO)	
Base		Extruded aluminum (A6063S-T5) White alumite treatment	
Maximum speed	mm/sec	1500 (1250 when ISAC motor is used)	
Static load (*1, 2)	N[kgf]	1176 [120]	1960[200]
Load moment (*3)	N·m[kgf·m]	Ma: 4.4[0.45] Mb: 3.9[0.4] Mc: 5.8[0.6]	Slides together: Ma: 27.4[2.8] Mb: 25.4[2.6] Mc: 11.7[1.2] Slides 70mm apart: Ma: 107[11] Mb: 98[10] Mc: 11.7[1.2]
Overhang load length L (*3)	mm	240	600 (slides together) 950 (slides 70mm apart)

- *1 Load uniformly distributed on slider. Base affixed to a flat, strong frame.
- *2 Value when load moment is not added. Static load is the maximum value when load is added and differs from the payload.
- *3 See figures at right. Moment caused by static load not to exceed allowable load moment. If there is moment in the Mc direction, we recommend using a guide rail (FS-11NO or 12NO) with the actuator.

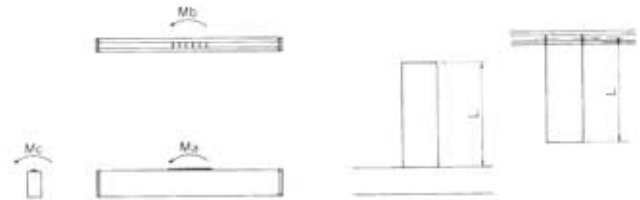

*70mm for 11WO

The drawing includes a top view showing stroke increments (A, B, C, D) and dimensions (100, 150, 200, 250, 300, 350, 400, 450, 500, 550, 600, 650, 700, 750, 800, 850, 900, 950, 1000). A side view shows the T-slot profile with dimensions 100, 150, 200, 250, 300, 350, 400, 450, 500, 550, 600, 650, 700, 750, 800, 850, 900, 950, 1000. A T-slot cross-section shows dimensions 20.2 ± 0.2, 10.2 ± 0.2, and 28.

FS-11WO-0									FS-12WO-0								
Stroke	300	400	600	800	1000	1500	2000	2500	Stroke	300	400	600	800	1000	1500	2000	2500
A	551	651	851	1051	1251	1751	2251	2751	A	651	751	951	1151	1351	1851	2351	2851
B	535	635	835	1035	1235	1735	2235	2735	B	635	735	935	1135	1335	1835	2335	2835
C	300	400	600	800	1000	1500	2000	2500	C	330	430	630	830	1030	1530	2030	2530
D	370	470	670	870	1070	1570	2070	2570	D	470	570	770	970	1170	1670	2170	2670

Stroke Increment is 100mm

FS-Series
Catalogue No. 0701-E

Providing quality products since 1986



IAI Industrieroboter GmbH

Ober der Röth 4

D-65824 Schwalbach am Taunus

Tel.: +49-6196-8895-0

Fax: +49-6196-8895-24

E-Mail: info@iai-gmbh.de

Internet: <http://www.IntelligentActuator.de>

IAI America Inc.

2690 W. 237th Street

Torrance

CA 90505

USA

Tel.: +1-310-891-6015

Fax: +1-310-891-0815

IAI Corporation

645-1 Hirose

Shimizu-City

Shizuoka 424-0102

Japan

Tel.: +81-543-64-5105

Fax: +81-543-64-5182