

# ISPA/ICSPA

## Single-Axis Robot/ Cartesian Robot Catalog - Extract PDF 3/3 -

- Features and Configurations (p41-66)
- ICSPA3/ ICSPA3 3-Axes Cartesian Robots (p129-225)
- Controllers (p226-260)



Catalog No. ISPA-CJ0063-3A



Quality and Innovation



# Cartesian Robots

**ICSA2/ICSPA2**

**ICSA3/ICSPA3**

## Contents

■ Cartesian Robot Series Contents	42
■ Features	43
■ Product Types	45
■ Two-Axes Configuration Unit Selection Table	47
■ Three-Axes Configuration Unit Selection Table	49
■ Points to Note	59
■ Explanation of Model Specification Items	61
■ Installation Method	63
■ System Configuration	65

Cartesian Robot Series **Contents**

Two-Axes Configuration	X-Y Two-Axes Configuration	XYB (Y-Axis Base Mount) Type	ICSA2(ICSPA2)-BA□ H	67			
			ICSA2(ICSPA2)-BA□ M	69			
			ICSA2(ICSPA2)-BB□ H	71			
			ICSA2(ICSPA2)-BB□ M	73			
			ICSA2(ICSPA2)-BC□ H	75			
			ICSA2(ICSPA2)-BC□ M	77			
			ICSA2(ICSPA2)-BD□ H	79			
			ICSA2(ICSPA2)-BE□ H	81			
			ICSA2(ICSPA2)-BE□ M	83			
			ICSA2(ICSPA2)-BF□ H	85			
			XYS (Y-Axis Slider Mount) Type	ICSA2(ICSPA2)-SA□ H	87		
				ICSA2(ICSPA2)-SA□ M	89		
				ICSA2(ICSPA2)-S1C□ H	91		
				ICSA2(ICSPA2)-S1C□ M	93		
				ICSA2(ICSPA2)-S2C□ H	95		
				ICSA2(ICSPA2)-SG□ H	97		
			X-Z Two-Axes Configuration	XZ (Z-Axis Base Mount) Type	ICSA2(ICSPA2)-ZAH	99	
					ICSA2(ICSPA2)-ZAM	101	
	ICSA2(ICSPA2)-Z1CH	103					
	ICSA2(ICSPA2)-Z1CM	105					
	ICSA2(ICSPA2)-Z2CH	107					
	ICSA2(ICSPA2)-ZDH	109					
	ICSA2(ICSPA2)-ZGH	111					
	ICSA2(ICSPA2)-ZHH	113					
Y-Z Two-Axes Configuration	YZ (Y-Axis Slider Mount) Type	ICSA2(ICSPA2)-YAH			115		
		ICSA2(ICSPA2)-YAM			117		
		ICSA2(ICSPA2)-YCH			119		
		ICSA2(ICSPA2)-YCM			121		
		ICSA2(ICSPA2)-YGH	123				
		ICSA2(ICSPA2)-G1JH	125				
X-Y Two-Axes Gantry Configuration	XYG (Gantry) Type	ICSA2(ICSPA2)-G2JH	127				
Three-Axes Configuration	X-Y Base Mount (XYB) + Z-Axis Configuration	Z-Axis Base Mount Type (Z-Axis Slider Flexible)	ICS(P)A3-BA□MB1□	129			
			ICS(P)A3-BB□HB1□	131			
			ICS(P)A3-BB□MB1□	133			
			ICS(P)A3-BB□MB2□	135			
			ICS(P)A3-BC□HB1□	137			
			ICS(P)A3-BC□HB2□	139			
			ICS(P)A3-BC□HB3□	141			
			ICS(P)A3-BC□MB1□	143			
			ICS(P)A3-BC□MB2□	145			
			ICS(P)A3-BC□MB3□	147			
			ICS(P)A3-BD□HB1□	149			
			ICS(P)A3-BD□HB2□	151			
			ICS(P)A3-BD□HB3□	153			
			ICS(P)A3-BE□HB1□	155			
			ICS(P)A3-BE□HB2□	157			
			ICS(P)A3-BE□HB3□	159			
			ICS(P)A3-BE□MB2□	161			
			ICS(P)A3-BE□MB3□	163			
			ICS(P)A3-BF□MB1□	165			
			ICS(P)A3-BF□HB2□	167			
			ICS(P)A3-BF□HB3□	169			
			Z-Axis Slider Mount Type (Z-Axis Body Flexible)	ICS(P)A3-BA□MS1□	171		
				ICS(P)A3-BB□HS1□	173		
				ICS(P)A3-BB□MS1□	175		
				ICS(P)A3-BC□HS1□	177		
				ICS(P)A3-BC□HS3□	179		
				ICS(P)A3-BC□MS1□	181		
				ICS(P)A3-BC□MS3□	183		
				ICS(P)A3-BD□HS1□	185		
				ICS(P)A3-BD□HS3□	187		
				ICS(P)A3-BE□HS1□	189		
				ICS(P)A3-BE□HS3□	191		
				ICS(P)A3-BE□MS1□	193		
				ICS(P)A3-BE□MS3□	195		
				ICS(P)A3-BF□HS1□	197		
				ICS(P)A3-BF□HS3□	199		
				X-Y Gantry (XYG) + Z-Axis Configuration	Z-Axis Base Mount Type (Z-Axis Slider Flexible)	ICS(P)A3-G1JHB1□	201
						ICS(P)A3-G1JHB2□	203
						ICS(P)A3-G1JHB3□	205
			ICS(P)A3-G2JHB1□			207	
			ICS(P)A3-G2JHB2□			209	
			ICS(P)A3-G2JHB3□			211	
			Z-Axis Slider Mount Type (Z-Axis Body Flexible)		ICS(P)A3-G1JHS1□	213	
					ICS(P)A3-G1JHS2□	215	
					ICS(P)A3-G1JHS3□	217	
					ICS(P)A3-G2JHS1□	219	
					ICS(P)A3-G2JHS2□	221	
					ICS(P)A3-G2JHS3□	223	

\* In the above model names, □ indicates the configuration direction (1 through 4).

# Cartesian Robot Series Features

The ICSA/ICSPA Cartesian robots are configuration units based on the two-axes and three-axes configuration patterns that are frequently used. These actuators come pre-wired with brackets attached, so they can be installed in your equipment and used immediately after delivery.

## 1. Configuration Variations

Fifty-seven standard configuration types are provided, so the user can find the model best suited to existing conditions. We can also build custom configurations not currently represented in the standard range. Please contact us regarding your specifications.

### Two-Axes Configuration Type

Two-axes configuration units are available in **31 types**, each combining one of five configuration patterns with different speeds and motor capacities.

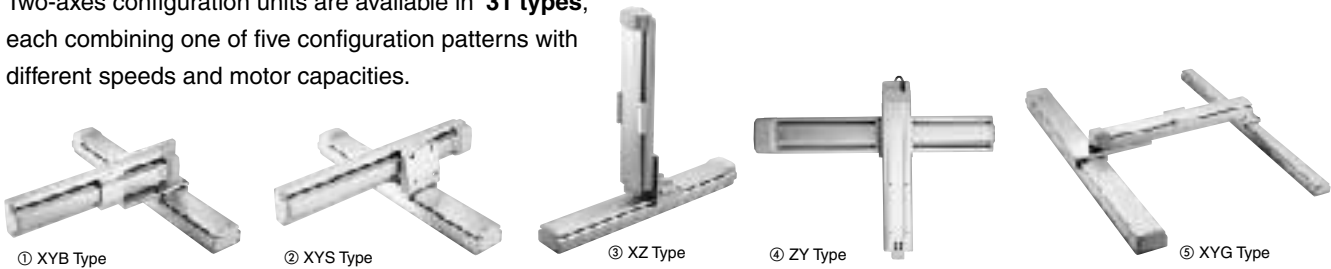

#### 1 XYB (Y-Axis Base Mount) Type

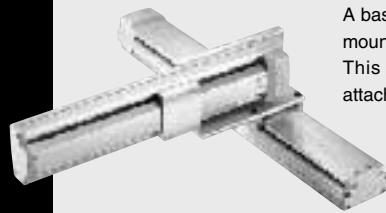

A basic configuration type where the Y-axis base is mounted to the X-axis bracket. This actuator operates with a device or Z-axis attached to the Y-axis slider.

- Point 1** There are four patterns of Y-axis configuration directions to choose from (refer to the figure shown to right).
- Point 2** Select the Y-axis wiring specification from the two options of self-standing cable (standard) and cable track.

#### ■ Configuration Direction

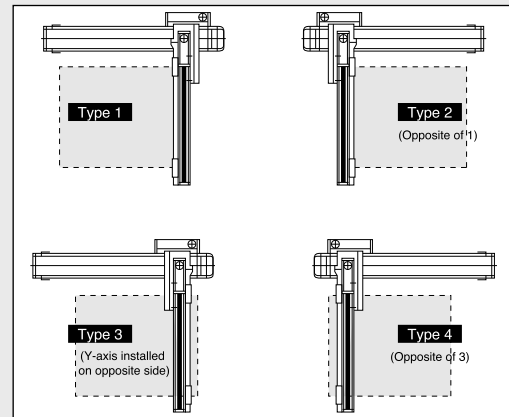

#### 2 XYS (Y-Axis Slider Mount) Type

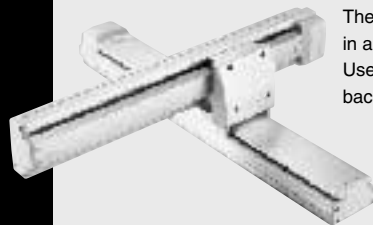

The Y-axis slider is mounted to the X-axis bracket in a manner allowing the Y-axis to move. Use this type when the Y-axis itself must be moved back and forth to avoid an obstacle, etc.

- Point 1** There are four patterns of Y-axis configuration directions to choose from (refer to the figure shown to right).
- Point 2** Only the self-standing cable option is available for the Y-axis wiring specification.

#### ■ Configuration Direction

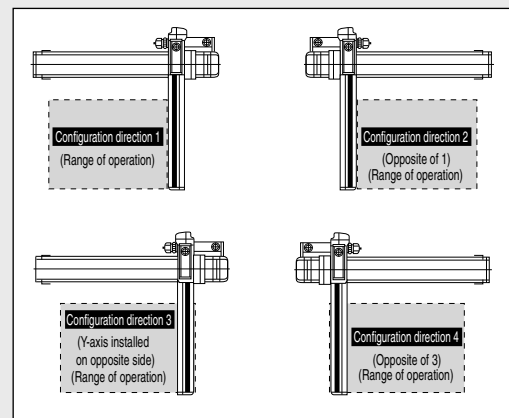

### ③ XZ (Z-Axis Base Mount) Type

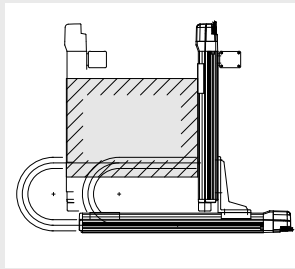

The Z-axis (vertical axis) is positioned vertically on the X-axis. Use this type in such applications as inserting loads into a stocker or moving a pallet up and down.

- Point 1** Since the Z-axis comes standard with a brake, the slider will not drop even when the power is turned off.
- Point 2** The maximum stroke is 2500 mm for the X-axis and 500mm for the Z-axis. (Consult IAI if you need a longer stroke.)

### ④ YZ (Y-Axis Slider Mount) Type

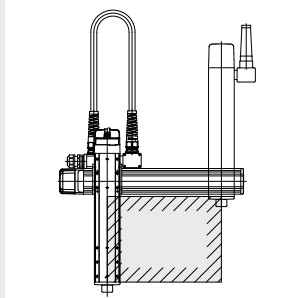

The Y-axis is positioned on its side and its slider is connected to the slider of the Z-axis (vertical axis). Since the Z-axis moves vertically, this type can be fitted with a chuck or other device on the Z-axis for transfer of loads.

- Point 1** Since the Z-axis comes standard with a brake, the slider will not drop even when the power is turned off.
- Point 2** The standard wiring specification of the Z-axis is the self-standing cable, but the cable track can also be used (custom order).
- Point 3** The Z-axis base can be mounted (custom order).

### ⑤ XYG (Gantry) Type

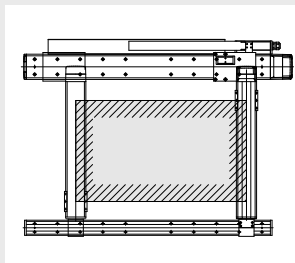
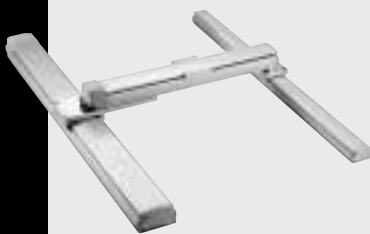

The Y-axis of the XYB type is placed flat and a support guide is attached at the tip of the Y-axis. Use this type for transferring heavy objects or when the Y-axis stroke is long and the tip might sag.

- Point 1** A maximum of 40 kg can be transferred.
- Point 2** The maximum stroke is 2500 mm for the X-axis and 1200 mm for the Y-axis. (Consult IAI if you need a longer stroke.)

## Three-Axes Configuration Type

Three-axes configuration units are available in **102 types**, each combining either the basic XYB (Y-axis base mount) type or high-rigidity XYG (gantry) type with a Z-axis (vertical axis) of high-speed, medium-speed or low-speed specification, providing a maximum load capacity of 19 kg.

**Consult IAI for details on three-axes combined types.**

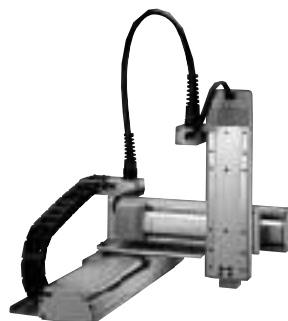

## Four-Axes Configuration Type

We also offer four-axes configuration types, which are three-axes configuration units with a rotating axis integrated with the Z-axis. Please advise us of your desired conditions, and we will select the best configuration and submit drawings.

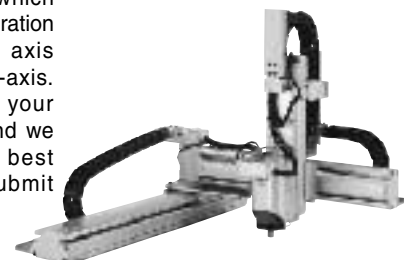

■ Two-Axes Configuration

**X-Y Two-Axes Configuration**

**Y-axis base mount**

The Y-axis slider moves horizontally.

- XYB** type
- BA□H, BA□M
  - BB□H, BB□M
  - BC□H, BC□M
  - BD□H
  - BE□H, BE□M
  - BF□H

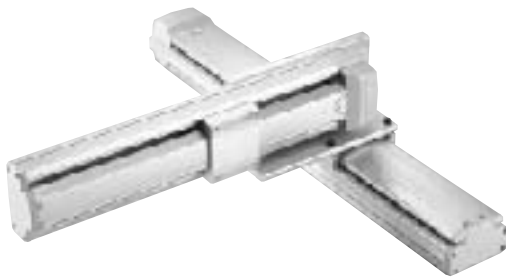

P67~86

**Y-axis slider mount**

The entire Y-axis moves horizontally.

- XYS** type
- SA□H, SA□M
  - S1C□H, S1C□M
  - S2C□H
  - SG□H

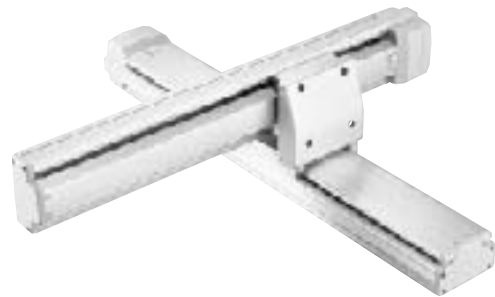

P87~98

■ Three-Axes Configuration

**X-Y Base Mount (XYB)+Z-Axis Configuration**

**Z-Axis Base Mount Type**

The Z-axis is base mounted to the Y slider.  
The Z slider moves vertically.  
The Y-axis slider moves horizontally.

- BA□MB1□
- BB□HB1□
- BB□MB1□
- BC□HB□□
- BC□MB□□
- BD□HB□□
- BE□HB□□
- BE□MB□□
- BF□HB□□

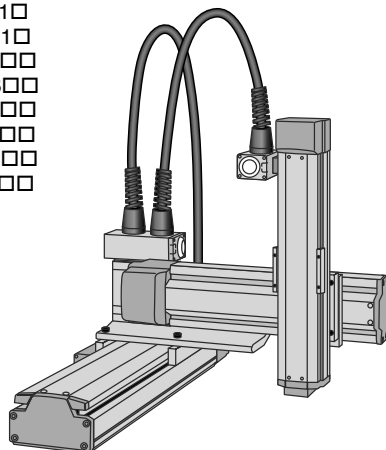

P129~170

**Z-Axis Slider Mount Type**

The Z-axis slider is mounted to the Y-axis slider.  
The body of the Z-axis moves vertically.  
The Y-axis slider moves horizontally.

- BA□MS1□
- BB□HS1□
- BB□MS□□
- BC□HS□□
- BC□MS□□
- BD□HS□□
- BE□HS□□
- BE□MS□□
- BF□HS□□

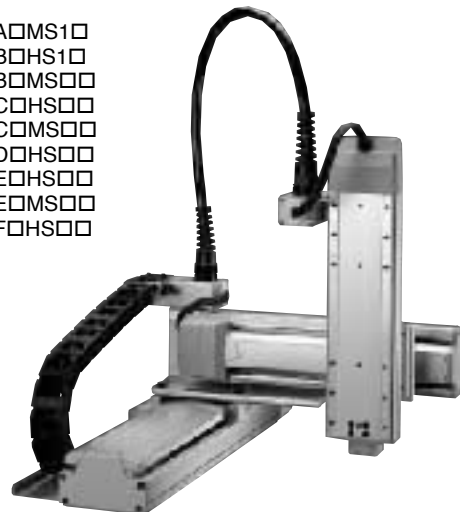

P171~200

**Z-axis base mount**

The Z-axis is positioned vertically and mounted to the X-axis. The Z-axis slider moves vertically.

**XZ** type

- ZAH, ZAM
- Z1CH, Z1CM
- Z2CH
- ZDH
- ZGH
- ZHH

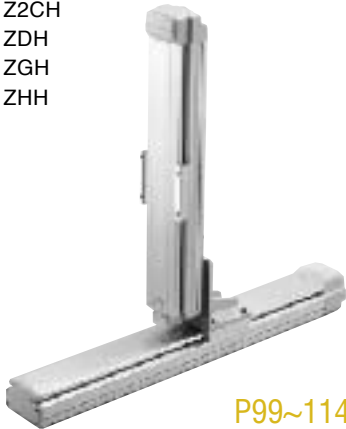

P99~114

**Y-axis slider mount**

The Z-axis slider is mounted to the Y-axis positioned on its side. The entire Z-axis moves vertically.

**YZ** type

- YAH, YAM
- YCH, YCM
- YGH

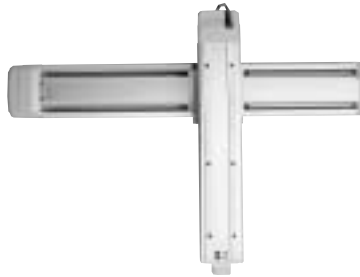

P115~124

**Gantry**

A support axis is added in parallel with the X-axis and the Y-axis base is mounted to the sliders on the two axes. The Y-axis slider moves horizontally.

**XYG** type

- G1JH
- G2JH

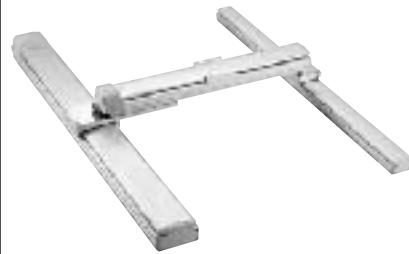

P125~128

**Four-Axes Configuration**

**X-Y Gantry (XYG)+Z-Axis Configuration**

**Z-Axis Base Mount Type**

The Z-axis base mounted to the Y-axis, Z slider moves vertically. The Y-axis slider moves horizontally.

- G1JHB□□
- G2JHB□□

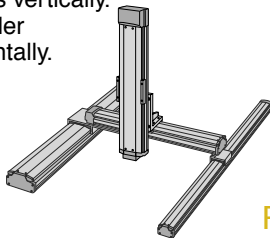

P201~212

**Z-Axis Slider Mount Type**

The Z-axis slider is mounted to the Y-axis slider and moves vertically. The Y-axis slider moves horizontally.

- G1JHS□□
- G2JHS□□

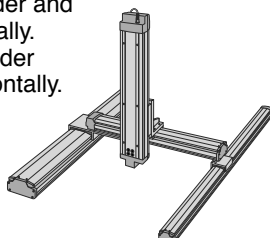

P213~224

**X-Y Base Mount + Z-Axis + Rotating-Axis Configuration**

Rotating-axis mounted to the Z-axis base (Z-slider mounted to Y) of three-axes configuration provides theta motion.

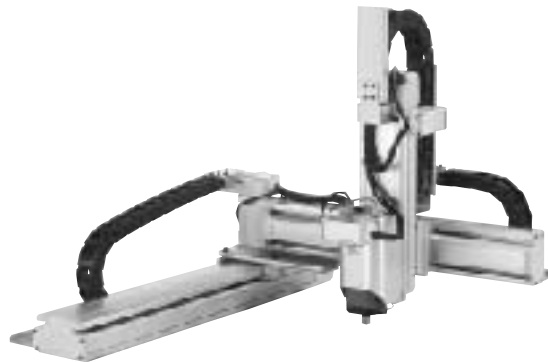

# Cartesian Robot Series Two-Axes Configuration Unit Selection Table

## How to Select a Unit (Explanation of the Table)

Start from • and move toward right as you confirm each condition to select a desired type.

### ① Select the configuration.

- XYB type** The Y-axis base is mounted to the X-axis. (The Y-axis slider moves horizontally.)
- XYS type** The Y-axis slider is mounted to the X-axis. (The Y-axis itself moves horizontally.)
- XZ type** The Z-axis is positioned vertically and mounted to the X-axis. (The Z-axis slider moves vertically.)
- YZ type** The Z-axis slider is mounted to the Y-axis positioned on its side. (The Z-axis itself moves vertically.)
- XYG type** A support axis is added in parallel with the X-axis and the Y-axis base is mounted to the sliders on the two axes. (The Y-axis slider moves horizontally.)

② Select the line that satisfies both the required Y-axis (Z-axis) stroke and load capacity, and then follow that line to the next column on right (Fields with a "-" indicate that this particular configuration is not supported.)

### ③ Check the X-axis stroke.

If the condition is not satisfied, go down to the line below and select a larger type.

### ④ Select the desired speed.

⑤ You have selected the type that satisfies all your desired conditions.

Refer to page 43 for the X/Y-axis configuration directions.

Select the X/Y-axis and Z-axis wiring specifications from the following two options:

SC : Self-standing cable  
CT : Cable track

\* Refer to page 45.

①

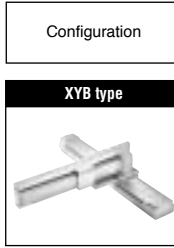

Configuration

XYB type

Load capacity (kg)	Y-axis stroke (mm)						
	100	200	300	400	500	600	700
•	5.2	4.5	3.8	3.1	-	-	-
	18.2	16.6	12.1	8.1	-	-	-
	12.0		11.8	11.1	-	-	-
	25.0			21.8	-	-	-
	20.0				18.7	-	-
	28.8	27.8	26.8	21.8	18.7	-	-
	20.0				18.7	-	-
	-	40.0		33.0	27.3	22.9	19.3
	-	51.2	40.5	33.0	27.3	22.9	19.3
	-	40.0		33.0	27.3	22.9	19.3



XYS type

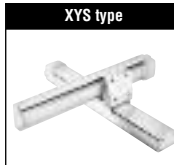

Load capacity (kg)	Y-axis stroke (mm)						
	100	200	300	400	500	600	700
•	6.2	5.5	4.8	4.1	-	-	-
	19.2	14.3	9.3	6.4	-	-	-
	9.7	8.7	7.7	6.7	5.6	-	-
	29.7	29.1	19.3	13.6	9.7	-	-
	29.2	28.2	19.3	13.6	9.7	-	-
	-	-	20.7	18.2	12.5	8.4	-



XZ type



Load capacity (kg)	Z-axis stroke (mm)						
	100	200	300	400	500	600	700
•	4.0	3.3	2.6	-	-	-	-
	10.0	7.5	6.0	-	-	-	-
	8.5	7.5	6.5	5.5	-	-	-
	19.0	17.0	14.0	12.0	-	-	-
	19.0	16.0	13.0	11.0	-	-	-
	19.0	16.0	13.0	11.0	-	-	-
	22.0	18.0	16.0	12.0	10.0	-	-
	22.0	18.0	16.0	12.0	10.0	-	-



YZ type



Load capacity (kg)	Z-axis stroke (mm)						
	100	200	300	400	500	600	700
•	3.0	2.3	1.6	-	-	-	-
	11.0	10.3	9.6	-	-	-	-
	11.9	10.9	9.9	8.9	-	-	-
	13.1	12.1	11.1	10.1	-	-	-
	27.0	25.5	23.9	22.3	20.7	-	-



XYG type

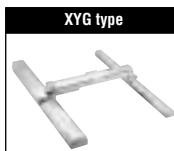

Load capacity (kg)	Y-axis stroke (mm)	
	500 ~ 700	800 ~ 1200
•	40.0	-
	-	40.0







**Caution**

The maximum speed of some long-stroke types (indicated by \*) has been reduced to prevent the ball screw from reaching a dangerous speed. Once the desired type has been selected, check the actual speed specification on the page corresponding to the selected type.

3

X-axis stroke (mm)
100 ~ 600
100 ~ 600
200 ~ 800
200 ~ 800
200 ~ 800
200 ~ 800
800 ~ 2000
300 ~ 1000
300 ~ 1000
1000 ~ 2500

4

Maximum speed (X-axis/Y-axis) (mm/sec)
800/800
400/400
*1000/800
*500/400
*1000/1000
*500/500
*1000/1000
*1000/1000
*500/500
*1000/1000

5 Applicable type

Configuration type	Page
<b>BA□H</b>	→ P67
<b>BA□M</b>	→ P69
<b>BB□H</b>	→ P71
<b>BB□M</b>	→ P73
<b>BC□H</b>	→ P75
<b>BC□M</b>	→ P77
<b>BD□H</b>	→ P79
<b>BE□H</b>	→ P81
<b>BE□M</b>	→ P83
<b>BF□H</b>	→ P85

X-axis stroke

(mm)
100 ~ 600
100 ~ 600
200 ~ 800
200 ~ 800
200 ~ 800
300 ~ 800

Maximum speed (X-axis/Y-axis)

(mm/sec)
800/800
400/400
*1000/1000
*500/500
*1000/1000
1000/1000

Configuration type

Page	
<b>SA□H</b>	→ P87
<b>SA□M</b>	→ P89
<b>S1C□H</b>	→ P91
<b>S1C□M</b>	→ P93
<b>S2C□H</b>	→ P95
<b>SG□H</b>	→ P97

X-axis stroke

(mm)
100 ~ 600
100 ~ 600
200 ~ 800
200 ~ 800
200 ~ 800
800 ~ 2000
200 ~ 800
1000 ~ 2500

Maximum speed (X-axis/Z-axis)

(mm/sec)
800/400
400/200
*1000/500
*500/250
*1000/500
*1000/500
1000/500
*1000/500

Configuration type

Page	
<b>ZAH</b>	→ P99
<b>ZAM</b>	→ P101
<b>Z1CH</b>	→ P103
<b>Z1CM</b>	→ P105
<b>Z2CH</b>	→ P107
<b>ZDH</b>	→ P109
<b>ZGH</b>	→ P111
<b>ZHH</b>	→ P113

Y-axis stroke

(mm)
100 ~ 400
100 ~ 400
200 ~ 700
200 ~ 700
200 ~ 700

Maximum speed (Y-axis/Z-axis)

(mm/sec)
800/400
400/200
1000/500
*500/250
1000/500

Configuration type

Page	
<b>YAH</b>	→ P115
<b>YAM</b>	→ P117
<b>YCH</b>	→ P119
<b>YCM</b>	→ P121
<b>YGH</b>	→ P123

X-axis stroke

(mm)
1000 ~ 2500
1000 ~ 2500

Maximum speed (X-axis/Y-axis)

(mm/sec)
*1000/1000
*1000/1000

Configuration type

Page	
<b>G1JH</b>	→ P125
<b>G2JH</b>	→ P127

# Cartesian Robots Series Three-Axes Configuration Unit Selection Table

**How to Select a Unit (Explanation of the Table)** Start from ① and move toward right as you confirm each condition to select a desired type.

**① Select the installation method of Z-axis from the followings:**

- [Z-Axis Base Mount]  
(The Z-axis base is mounted to the Y-axis slider: The Z-axis slider moves vertically.)
- [Z-Axis Slider Mount]  
(The Z-axis slider is mounted to the Y-axis slider: The Z-axis itself moves vertically.)

**② Select the Z-axis type from High-speed, Mid-speed, and Low-speed.**

(The Slider Mount Type is available only in Mid-speed and Low-speed.)

**③ Select the load capacity for Z-axis**  
(total weight of load and jig)

**④ Select the desired Z-axis stroke from the chart.**

**⑤ Check the Y-axis stroke and load capacity.**

(If the condition is not satisfied, go down to the line below and select larger load capacity.)

**⑥ Check the X-axis stroke.**

If the condition is not satisfied, go down to the line below and select larger type.

\* ( ) specifies the case of B□□H□□ or BF□H□□.

**⑦ Check the maximum speed for X-axis and Y-axis.**

If the condition is not satisfied, go down to the line below and select larger type.

**⑧ You have selected the type that satisfies all your desired conditions.**

Refer to page 45 for the X/Y-Axis configuration directions.

Select the X/Y-Axis and Z-Axis wiring specifications from the two options to the right.

Only cable track is available for X/Y-Axis type D, F, 1J, and 2J.

Only Self-standing cable is available for Z-Axis Slider Mount Type.

We can also build custom configurations not currently represented in the standard range.

Please contact us regarding your specifications.

SC: Self-standing cable  
CT: Cable track

\* Refer to page 225.

**[ Z-Axis Base Mount ] ①**

②

③

④

⑤

Z-Axis Speed Type	Z-Axis			Y-Axis Stroke (mm)								
	Load Capacity	Stroke (mm)		100	200	300	400	500	600	700	800~1200	
High-Speed Type 800~1000 mm/sec	3kg or less	100~300	→	3.0			-	-	-	-	-	-
		100~400		3.0			-	-	-	-	-	
		100~500		-	3.0			-	-	-	-	
		100~600		-	-	-	-	3.0		-	-	
		100~600		-	-	-	-	-	-	-	3.0	
	9kg or less	100	→	9.0			-	-	-	-	-	
		200		-	9.0			-	-	-		
		300		9.0	8.4	-	-	-	-			
		400		-	9.0			-	-	-		
		500		8.6	7.3	-	-	-	-			
		1000~600		-	9.0			7.9	-	-		
				7.6	6.3	-	-	-	-			
				-	9.0			6.9	-	-		
				-	9.0			5.8	-	-		
	-	-	-	-	9.0		-	-				
	-	-	-	-	-	-	-	9.0				

**Example of Selection**

**Conditions**  
 The Z-Axis is subject to base mount.  
 Allowable tip load : 2kg  
 Speed : 800mm/sec or more  
 Z-Axis Stroke : 200mm  
 Y-Axis Stroke : 500mm  
 X-Axis Stroke : 700MM

- ① Select the chart of [Z-Axis Base Mount Type].
- ② Select ""High-speed"" type since the desired speed is 800mm/sec."
- ③ Select "3kg or less" since the load capacity is 2kg."
- ④ Move the line for 100~300 to the right since Z-Axis stroke is 200mm.
- ⑤ The crossed column for Z-Axis stroke 100~300mm and Y-Axis stroke 500mm reads "---" (Not applicable), so apply the line below. Since the Y-Axis stroke on the line covers 500mm, shift to the right."
- ⑥ The X-Axis stroke is applicable up to 800mm, so shift to the right."
- ⑦ The maximum speed for X-Axis/ Y Axis is 1000mm/sec and satisfy the condition. Shift to the right.
- ⑧ As a result, Unit Type [BC□HB1H] is the selected suitable model."

**Note** The numbers in ( ) in X-Axis stroke in the chart below are for models in ( ) listed in Applicable Type's configuration type.  
 Example: If the X-Axis stroke in the above example is 1000mm, configuration Applicable Type will be [BD□HB1H].

⑥ \* ( ) is for the type BD□HB□□ or BF□HB□□.

⑦

⑧ **Applicable Type**

	X-Axis Stroke		Maximum Speed (X-axis / Y-axis)		Configuration Type	Page
	(mm)		(mm/sec)			
→	200~800		1000/800	→	ICSA [ICSPA] 3-BB□HB1H	• P131
	200~800 (800~2000)		1000/1000		ICSA [ICSPA] 3-BC□HB1H (BD□HB1H)	• P137 (P149)
	300~1000 (1000~2500)		1000/1000		ICSA [ICSPA] 3-BE□HB1H (BF□HB1H)	• P155 (P165)
	1000~2500		1000/1000		ICSA [ICSPA] 3-G1JHB1H	• P201
→	200~800 (800~2000)		1000/1000	→	ICSA [ICSPA] 3-BC□HB3H (BD□HB3H)	• P141 (P153)
	300~1000 (1000~2500)		1000/1000		ICSA [ICSPA] 3-BE□HB3H (BF□HB3H)	• P159 (P169)
	200~800 (800~2000)		1000/1000		ICSA [ICSPA] 3-BC□HB3H (BD□HB3H)	• P141 (P153)
	300~1000 (1000~2500)		1000/1000		ICSA [ICSPA] 3-BE□HB3H (BF□HB3H)	• P159 (P169)
	200~800 (800~2000)		1000/1000		ICSA [ICSPA] 3-BC□HB3H (BD□HB3H)	• P141 (P153)
	300~1000 (1000~2500)		1000/1000		ICSA [ICSPA] 3-BE□HB3H (BF□HB3H)	• P159 (P169)
	200~800 (800~2000)		1000/1000		ICSA [ICSPA] 3-BC□HB3H (BD□HB3H)	• P141 (P153)
	300~1000 (1000~2500)		1000/1000		ICSA [ICSPA] 3-BE□HB3H (BF□HB3H)	• P159 (P169)
	200~800 (800~2000)		1000/1000		ICSA [ICSPA] 3-BC□HB3H (BD□HB3H)	• P141 (P153)
	300~1000 (1000~2500)		1000/1000		ICSA [ICSPA] 3-BE□HB3H (BF□HB3H)	• P159 (P169)
	300~1000 (1000~2500)		1000/1000		ICSA [ICSPA] 3-BE□HB3H (BF□HB3H)	• P159 (P169)
	1000~2500		1000/1000		ICSA [ICSPA] 3-G1JHB3H	• P205
			1000/1000		ICSA [ICSPA] 3-G2JHB3H	• P211

[ Z-Axis Base Mount ] ①

②

③

④

⑤

Z-Axis Speed Type	Z-Axis			Y-Axis Stroke (mm)									
	Load Capacity	Stroke (mm)		100	200	300	400	500	600	700	800~1200		
Mid-Speed Type 400~500 mm/sec	6kg or less	100	→	Load Capacity (kg)	6.0				2.9	-	-	-	-
					6.0				5.9	-	-	-	-
		6.0				-	-	-	-	-			
		200			6.0			2.3	-	-	-	-	
					6.0			5.3	-	-	-	-	
		300			6.0				-	-	-	-	
					6.0		5.7	1.7	-	-	-	-	
		5.6			5.4	4.7	-	-	-	-			
		6.0				-	-	-	-				
		6.0				-	-	-	-				
-				6.0				-					
-				-	-	-	6.0	-					
-				-	-	-	-	6.0					
Mid-Speed Type 400~500 mm/sec	9kg or less	100	→	Load Capacity (kg)	9.0				-	-	-	-	
					9.0				-	-	-	-	
		9.0				-	-	-	-				
		200			9.0			8.4	-	-	-		
					9.0			-	-	-	-		
		300			8.6				7.3	-	-		
					9.0			-	-	7.9	-		
		400			7.6		6.3	-	-	-			
					9.0				-	6.9	-		
		9.0				-	5.8	-					
-				9.0				-					
-				-	-	-	9.0	-					
Mid-Speed Type 400~500 mm/sec	19kg or less	100	→	Load Capacity (kg)	10.7				9.4	-	-	-	
					19.0	18.5	17.5	12.5	9.4	-	-	-	
		19.0				18.0	13.6	10.0	-				
		19.0				-	-	-	19.0				
		19.0				-	-	-	19.0				
		19.0				-	-	-	19.0				
	200	9.7			8.4	-	-	-					
		18.5			17.5	16.5	11.5	8.4	-	-			
		19.0			17.0	12.6	9.0	-					
		19.0				-	-	-					
		19.0				-	-	-					
		19.0				-	-	-					
	300	8.6				7.3	-	-					
		17.4			16.4	15.4	10.4	7.3	-	-			
		19.0			15.9	11.5	7.9	-					
		19.0				-	-	-					
		19.0				-	-	-					
		19.0				-	-	-					
400	7.6			6.3	-	-	-						
	16.4	15.4	14.4	9.4	6.3	-	-						
	19.0			14.9	10.5	6.9	-						
	18.7				-	-	-						
	18.7				-	-	-						
	18.7				-	-	-						
500	19.0				13.8	9.4	5.8	-					
	17.6				-	-	-						
	17.6				-	-	-						
	17.6				-	-	-						
	17.6				-	-	-						
	17.6				-	-	-						
600	16.6				-	-	-						
	16.6				-	-	-						

6 * ( ) is for the type BD□HB□□ or BF□HB□□.		7		8 Applicable Type	
X-Axis Stroke		Maximum Speed (X-axis / Y-axis)		Configuration Type	Page
(mm)		(mm/sec)			
100~600		400/400		ICSA [ICSPA] 3-BA□MB1M	• P129
200~800		1000/800		ICSA [ICSPA] 3-BB□HB1M	• P131
200~800		500/400		ICSA [ICSPA] 3-BB□MB1M	• P133
100~600		400/400		ICSA [ICSPA] 3-BA□MB1M	• P129
200~800		1000/800		ICSA [ICSPA] 3-BB□HB1M	• P131
200~800		500/400		ICSA [ICSPA] 3-BB□MB1M	• P133
100~600		400/400		ICSA [ICSPA] 3-BA□MB1M	• P129
200~800		1000/800		ICSA [ICSPA] 3-BB□HB1M	• P131
200~800		500/400		ICSA [ICSPA] 3-BB□MB1M	• P133
200~800		1000/1000		ICSA [ICSPA] 3-BC□HB1M (BD□HB1M)	• P137 (P149)
300~1000		1000/1000		ICSA [ICSPA] 3-BE□HB1M (BF□HB1M)	• P155 (P165)
1000~2500		1000/1000		ICSA [ICSPA] 3-G1JHB1M	• P201
1000~2500		1000/1000		ICSA [ICSPA] 3-G2JHB1M	• P207
200~800		500/400		ICSA [ICSPA] 3-BB□MB2M	• P135
200~800 (800~2000)		1000/1000		ICSA [ICSPA] 3-BC□HB2M (BD□HB2M)	• P139 (P151)
300~1000 (1000~2500)		1000/1000		ICSA [ICSPA] 3-BE□HB2M (BF□HB2M)	• P157 (P167)
200~800 (800~2000)		1000/1000		ICSA [ICSPA] 3-BC□HB2M (BD□HB2M)	• P139 (P151)
300~1000 (1000~2500)		1000/1000		ICSA [ICSPA] 3-BE□HB2M (BF□HB2M)	• P157 (P167)
200~800 (800~2000)		1000/1000		ICSA [ICSPA] 3-BC□HB2M (BD□HB2M)	• P139 (P151)
300~1000 (1000~2500)		1000/1000		ICSA [ICSPA] 3-BE□HB2M (BF□HB2M)	• P157 (P167)
200~800 (800~2000)		1000/1000		ICSA [ICSPA] 3-BC□HB2M (BD□HB2M)	• P139 (P151)
300~1000 (1000~2500)		1000/1000		ICSA [ICSPA] 3-BE□HB2M (BF□HB2M)	• P157 (P167)
300~1000 (1000~2500)		1000/1000		ICSA [ICSPA] 3-BE□HB2M (BF□HB2M)	• P157 (P167)
1000~2500		1000/1000		ICSA [ICSPA] 3-G1JHB2M	• P203
1000~2500		1000/1000		ICSA [ICSPA] 3-G2JHB2M	• P209
200~800 (800~2000)		1000/1000		ICSA [ICSPA] 3-BC□HB3M (BD□HB3M)	• P141 (P153)
200~800		500/500		ICSA [ICSPA] 3-BC□MB3M	• P147
300~1000 (1000~2500)		1000/1000		ICSA [ICSPA] 3-BE□HB3M (BF□HB3M)	• P159 (P169)
1000~2500		1000/1000		ICSA [ICSPA] 3-G1JHB3M	• P205
1000~2500		1000/1000		ICSA [ICSPA] 3-G2JHB3M	• P211
200~800 (800~2000)		1000/1000		ICSA [ICSPA] 3-BC□HB3M (BD□HB3M)	• P141 (P153)
200~800		500/500		ICSA [ICSPA] 3-BC□MB3M	• P147
300~1000 (1000~2500)		1000/1000		ICSA [ICSPA] 3-BE□HB3M (BF□HB3M)	• P159 (P169)
1000~2500		1000/1000		ICSA [ICSPA] 3-G1JHB3M	• P205
1000~2500		1000/1000		ICSA [ICSPA] 3-G2JHB3M	• P211
200~800 (800~2000)		1000/1000		ICSA [ICSPA] 3-BC□HB3M (BD□HB3M)	• P141 (P153)
200~800		500/500		ICSA [ICSPA] 3-BC□MB3M	• P147
300~1000 (1000~2500)		1000/1000		ICSA [ICSPA] 3-BE□HB3M (BF□HB3M)	• P159 (P169)
1000~2500		1000/1000		ICSA [ICSPA] 3-G1JHB3M	• P205
1000~2500		1000/1000		ICSA [ICSPA] 3-G2JHB3M	• P211
300~1000 (1000~2500)		1000/1000		ICSA [ICSPA] 3-BE□HB3M (BF□HB3M)	• P159 (P169)
1000~2500		1000/1000		ICSA [ICSPA] 3-G1JHB3M	• P205
1000~2500		1000/1000		ICSA [ICSPA] 3-G2JHB3M	• P211
1000~2500		1000/1000		ICSA [ICSPA] 3-G1JHB3M	• P205
1000~2500		1000/1000		ICSA [ICSPA] 3-G2JHB3M	• P211

[ Z-Axis Base Mount ] ①

②

③

④

⑤

Z-Axis Speed Type	Z-Axis			Y-Axis Stroke (mm)								
	Load Capacity	Stroke (mm)		100	200	300	400	500	600	700	800~1200	
Low-Speed Type 200~250 mm/sec	14kg or less	100	→	13.0	11.4	6.9	2.9	-	-	-	-	
				7.1		6.9	6.2	-	-	-	-	
				14.0				-	-	-	-	
				14.0				13.5	-	-	-	
				-				14.0				-
				-				14.0				-
		200		12.4	10.8	6.3	2.3	-	-	-	-	
				6.1		5.9	5.2	-	-	-	-	
				14.0				-	-	-	-	
				14.0				12.9	-	-	-	
				-				14.0				13.5
				-				14.0				-
		300		11.8	10.2	5.7	1.7	-	-	-	-	
				5.6		5.4	4.7	-	-	-	-	
	14.0				-	-	-	-				
	14.0				12.3	-	-	-				
	-				14.0				12.9			
	-				14.0				-			
	400	-				14.0				12.3		
		-				14.0				11.7		
		-				14.0				11.7		
		-				14.0				-		
		-				14.0				-		
		-				14.0				-		
	500	-				14.0				-		
		-				14.0				-		
		-				14.0				-		
		-				14.0				-		
-				14.0				-				
-				14.0				-				
19kg or less	100	→	15.9		12.7	-	-	-	-			
			10.7				9.4	-	-	-		
			19.0	18.5	17.5	12.5	9.4	-	-	-		
			-				19.0	18.0	13.6	10.0		
			-				19.0				-	
			-				19.0				19.0	
	200		14.6				11.4	-	-	-		
			9.7				8.4	-	-	-		
			18.5	17.5	16.5	11.5	8.4	-	-	-		
			-				19.0	17.0	12.6	9.0		
			-				19.0				-	
			-				19.0				19.0	
	300		13.8				10.6	-	-	-		
			8.6				7.3	-	-	-		
17.4		16.4	15.4	10.4	7.3	-	-	-				
-				19.0	15.9	11.5	7.9					
-				19.0				-				
-				19.0				19.0				
400	12.8				9.6	-	-	-				
	7.6				6.3	-	-	-				
	16.4	15.4	14.4	9.4	6.3	-	-	-				
	-				19.0	14.9	10.5	6.9				
	-				18.7				-			
	-				18.7				18.7			
500	-				19.0				13.8			
	-				19.0				9.4			
	-				19.0				5.8			
	-				17.6				-			
	-				17.6				17.6			
	-				16.6				-			
100~600	-				-				16.6			
100~600	-				-				16.6			

6		7		8 Applicable Type	
X-Axis Stroke		Maximum Speed (X-axis / Y-axis)		Configuration Type	
(mm)		(mm/sec)		Page	
100~600		400/400		ICSA [ICSPA] 3-BA□MB1L	• P129
200~800		1000/1000		ICSA [ICSPA] 3-BB□HB1L	• P131
200~800		500/400		ICSA [ICSPA] 3-BB□MB1L	• P133
200~800 (800~2000)		1000/1000		ICSA [ICSPA] 3-BC□HB1L (BD□HB1L)	• P137 (P149)
300~1000 (1000~2500)		1000/1000		ICSA [ICSPA] 3-BE□HB1L (BF□HB1L)	• P155 (P165)
100~600		400/400		ICSA [ICSPA] 3-BA□MB1L	• P129
200~800		1000/1000		ICSA [ICSPA] 3-BB□HB1L	• P131
200~800		500/400		ICSA [ICSPA] 3-BB□MB1L	• P133
200~800 (800~2000)		1000/1000		ICSA [ICSPA] 3-BC□HB1L (BD□HB1L)	• P137 (P149)
300~1000 (1000~2500)		1000/1000		ICSA [ICSPA] 3-BE□HB1L (BF□HB1L)	• P155 (P165)
100~600		400/400		ICSA [ICSPA] 3-BA□MB1L	• P129
200~800		1000/1000		ICSA [ICSPA] 3-BB□HB1L	• P131
200~800		500/400		ICSA [ICSPA] 3-BB□MB1L	• P133
200~800 (800~2000)		1000/1000		ICSA [ICSPA] 3-BC□HB1L (BD□HB1L)	• P137 (P149)
300~1000 (1000~2500)		1000/1000		ICSA [ICSPA] 3-BE□HB1L (BF□HB1L)	• P155 (P165)
100~600		400/400		ICSA [ICSPA] 3-BA□MB1L	• P129
200~800		1000/1000		ICSA [ICSPA] 3-BB□HB1L	• P131
200~800		500/400		ICSA [ICSPA] 3-BB□MB1L	• P133
200~800 (800~2000)		1000/1000		ICSA [ICSPA] 3-BC□HB1L (BD□HB1L)	• P137 (P149)
300~1000 (1000~2500)		1000/1000		ICSA [ICSPA] 3-BE□HB1L (BF□HB1L)	• P155 (P165)
200~800		1000/1000		ICSA [ICSPA] 3-BC□HB1L (BD□HB1L)	• P137 (P149)
300~1000 (1000~2500)		1000/1000		ICSA [ICSPA] 3-BE□HB1L (BF□HB1L)	• P155 (P165)
300~1000 (1000~2500)		1000/1000		ICSA [ICSPA] 3-BE□HB1L (BF□HB1L)	• P155 (P165)
1000~2500		1000/1000		ICSA [ICSPA] 3-G1JHB1L	• P201
		1000/1000		ICSA [ICSPA] 3-G2JHB1L	• P207
200~800		1000/1000		ICSA [ICSPA] 3-BB□MB2L	• P135
200~800 (800~2000)		500/500		ICSA [ICSPA] 3-BC□HB2L (BD□HB2L)	• P139 (P151)
200~800		1000/1000		ICSA [ICSPA] 3-BC□MB2L	• P145
300~1000 (1000~2500)		1000/1000		ICSA [ICSPA] 3-BE□HB2L (BF□HB2L)	• P157 (P167)
1000~2500		1000/1000		ICSA [ICSPA] 3-G1JHB2L	• P203
		500/400		ICSA [ICSPA] 3-G2JHB2L	• P209
200~800		1000/1000		ICSA [ICSPA] 3-BB□MB2L	• P135
200~800		500/500		ICSA [ICSPA] 3-BC□HB2L (BD□HB2L)	• P139 (P151)
200~800		1000/1000		ICSA [ICSPA] 3-BC□MB2L	• P145
300~1000 (1000~2500)		1000/1000		ICSA [ICSPA] 3-BE□HB2L (BF□HB2L)	• P157 (P167)
1000~2500		1000/1000		ICSA [ICSPA] 3-G1JHB2L	• P203
		500/400		ICSA [ICSPA] 3-G2JHB2L	• P209
200~800		1000/1000		ICSA [ICSPA] 3-BB□MB2L	• P135
200~800 (800~2000)		500/500		ICSA [ICSPA] 3-BC□HB2L (BD□HB2L)	• P139 (P151)
200~800		1000/1000		ICSA [ICSPA] 3-BC□MB2L	• P145
300~1000 (1000~2500)		1000/1000		ICSA [ICSPA] 3-BE□HB2L (BF□HB2L)	• P157 (P167)
1000~2500		1000/1000		ICSA [ICSPA] 3-G1JHB2L	• P203
		1000/1000		ICSA [ICSPA] 3-G2JHB2L	• P209
200~800		1000/1000		ICSA [ICSPA] 3-BB□MB2L	• P135
200~800 (800~2000)		500/500		ICSA [ICSPA] 3-BC□HB2L (BD□HB2L)	• P139 (P151)
200~800		1000/1000		ICSA [ICSPA] 3-BC□MB2L	• P145
300~1000 (1000~2500)		1000/1000		ICSA [ICSPA] 3-BE□HB2L (BF□HB2L)	• P157 (P167)
1000~2500		1000/1000		ICSA [ICSPA] 3-G1JHB2L	• P203
		1000/1000		ICSA [ICSPA] 3-G2JHB2L	• P209
300~1000 (1000~2500)		1000/1000		ICSA [ICSPA] 3-BE□HB2L (BF□HB2L)	• P157 (P167)
1000~2500		1000/1000		ICSA [ICSPA] 3-G1JHB2L	• P203
		1000/1000		ICSA [ICSPA] 3-G2JHB2L	• P209
1000~2500		1000/1000		ICSA [ICSPA] 3-G1JHB2L	• P203
		1000/1000		ICSA [ICSPA] 3-G2JHB2L	• P209





6 \* ( ) is for the type BD□HB□□ or BF□HB□□.

7

8 Applicable Type

	X-Axis Stroke		Maximum Speed (X-axis / Y-axis)		Configuration Type	Page
	(mm)		(mm/sec)			
→	100~600	→	400/400	→	ICSA [ICSPA] 3-BA□MS1M	• P171
	200~800		1000/800		ICSA [ICSPA] 3-BB□HS1M	• P173
	200~800		500/500		ICSA [ICSPA] 3-BB□MS1M	• P175
	200~800 (800~2000)		1000/1000		ICSA [ICSPA] 3-BC□HS1M (BD□HS1M)	• P177 (P185)
	300~1000 (1000~2500)		1000/1000		ICSA [ICSPA] 3-BE□HS1M (BF□HS1M)	• P189 (P197)
	1000~2500		1000/1000		ICSA [ICSPA] 3-G1JHS1M	• P213
			1000/1000		ICSA [ICSPA] 3-G2JHS1M	• P219
	100~600		400/400		ICSA [ICSPA] 3-BA□MS1M	• P171
	200~800		1000/800		ICSA [ICSPA] 3-BB□HS1M	• P173
	200~800		500/500		ICSA [ICSPA] 3-BB□MS1M	• P175
	200~800 (800~2000)		1000/1000		ICSA [ICSPA] 3-BC□HS1M (BD□HS1M)	• P177 (P185)
	300~1000 (1000~2500)		1000/1000		ICSA [ICSPA] 3-BE□HS1M (BF□HS1M)	• P189 (P197)
	1000~2500		1000/1000		ICSA [ICSPA] 3-G1JHS1M	• P213
			1000/1000		ICSA [ICSPA] 3-G2JHS1M	• P219
	100~600		400/400		ICSA [ICSPA] 3-BA□MS1M	• P171
	200~800		1000/800		ICSA [ICSPA] 3-BB□HS1M	• P173
	200~800		500/500		ICSA [ICSPA] 3-BB□MS1M	• P175
	200~800 (800~2000)		1000/1000		ICSA [ICSPA] 3-BC□HS1M (BD□HS1M)	• P177 (P185)
	300~1000 (1000~2500)		1000/1000		ICSA [ICSPA] 3-BE□HS1M (BF□HS1M)	• P189 (P197)
	1000~2500		1000/1000		ICSA [ICSPA] 3-G1JHS1M	• P213
1000/1000		ICSA [ICSPA] 3-G2JHS1M	• P219			
200~800 (800~2000)	1000/1000	ICSA [ICSPA] 3-BC□HS3M (BD□HS3M)	• P179 (P187)			
300~1000 (1000~2500)	1000/1000	ICSA [ICSPA] 3-BE□HS3M (BF□HS3M)	• P191 (P199)			
1000~2500	1000/1000	ICSA [ICSPA] 3-G1JHS3M	• P217			
	1000/1000	ICSA [ICSPA] 3-G2JHS3M	• P223			
200~800 (800~2000)	1000/1000	ICSA [ICSPA] 3-BC□HS3M (BD□HS3M)	• P179 (P187)			
300~1000 (1000~2500)	1000/1000	ICSA [ICSPA] 3-BE□HS3M (BF□HS3M)	• P191 (P199)			
1000~2500	1000/1000	ICSA [ICSPA] 3-G1JHS3M	• P217			
	1000/1000	ICSA [ICSPA] 3-G2JHS3M	• P223			
200~800 (800~2000)	1000/1000	ICSA [ICSPA] 3-BC□HS3M (BD□HS3M)	• P179 (P187)			
300~1000 (1000~2500)	1000/1000	ICSA [ICSPA] 3-BE□HS3M (BF□HS3M)	• P191 (P199)			
1000~2500	1000/1000	ICSA [ICSPA] 3-G1JHS3M	• P217			
	1000/1000	ICSA [ICSPA] 3-G2JHS3M	• P223			
300~1000 (1000~2500)	1000/1000	ICSA [ICSPA] 3-BC□HS3M (BD□HS3M)	• P179 (P187)			
1000~2500	1000/1000	ICSA [ICSPA] 3-BE□HS3M (BF□HS3M)	• P191 (P199)			
	1000/1000	ICSA [ICSPA] 3-G1JHS3M	• P217			
1000~2500	1000/1000	ICSA [ICSPA] 3-G2JHS3M	• P223			
	1000/1000	ICSA [ICSPA] 3-G1JHS3M	• P217			
1000~2500	1000/1000	ICSA [ICSPA] 3-G2JHS3M	• P223			
	1000/1000	ICSA [ICSPA] 3-G1JHS3M	• P217			

[ Z-Axis Slider Mount ] ①

②

③

④

⑤

Z-Axis Speed Type	Z-Axis			Y-Axis Stroke (mm)							
	Load Capacity	Stroke (mm)		100	200	300	400	500	600	700	800~1200
Low-Speed Type 400~500 mm/sec	11 kg or less	100	→	11.0	7.6	3.6	-	-	-	-	-
				7.2	7.0	6.3	-	-	-	-	
				11.0			-	-	-	-	-
				11.0				-	-	-	-
				-	11.0					-	-
				-	-	-	-	11.0			-
		-		-	-	-	-	-	-	11.0	
		10.3		6.9	2.9	-	-	-	-		
		6.5		6.3	5.6	-	-	-	-		
		10.3			-	-	-	-			
		10.3				-	-	-			
		-		10.3					-	-	
	-	-		-	-	10.3			-		
	-	-		-	-	-	-	-	10.3		
	9.6	6.2		2.2	-	-	-	-			
	5.8	5.6		4.9	-	-	-	-			
	9.6			-	-	-	-				
	9.6				-	-	-				
	-	9.6					-	-			
	-	-		-	-	9.6			-		
	-	-		-	-	-	-	-	9.6		
	-	8.9					-	-			
	-	-		-	-	8.9			-		
	-	-		-	-	-	-	-	8.9		

⑥ \* ( ) is for the type BD□HB□□ or BF□HB□□.

⑦

⑧ Applicable Type

X-Axis Stroke		Maximum Speed (X-axis / Y-axis)		Configuration Type		Page
(mm)		(mm/sec)				
100~600		400~400		ICSA [ICSPA] 3-BA□MS1L		• P171
200~800		1000~800		ICSA [ICSPA] 3-BB□HS1L		• P173
200~800		500~400		ICSA [ICSPA] 3-BB□MS1L		• P175
200~800 (800~2000)		1000~1000		ICSA [ICSPA] 3-BC□HS1L (BD□HS1L)		• P177 (P185)
300~1000 (1000~2500)		1000~1000		ICSA [ICSPA] 3-BE□HS1L (BF□HS1L)		• P189 (P197)
1000~2500		1000~1000		ICSA [ICSPA] 3-G1JHS1L		• P213
		1000~1000		ICSA [ICSPA] 3-G2JHS1L		• P219
100~600		400~400		ICSA [ICSPA] 3-BA□MS1L		• P171
200~800		1000~800		ICSA [ICSPA] 3-BB□HS1L		• P173
200~800		500~400		ICSA [ICSPA] 3-BB□MS1L		• P175
200~800 (800~2000)		1000~1000		ICSA [ICSPA] 3-BC□HS1L (BD□HS1L)		• P177 (P185)
300~1000 (1000~2500)		1000~1000		ICSA [ICSPA] 3-BE□HS1L (BF□HS1L)		• P189 (P197)
1000~2500		1000~1000		ICSA [ICSPA] 3-G1JHS1L		• P213
		1000~1000		ICSA [ICSPA] 3-G2JHS1L		• P219
100~600		400~400		ICSA [ICSPA] 3-BA□MS1L		• P171
200~800		1000~800		ICSA [ICSPA] 3-BB□HS1L		• P173
200~800		500~400		ICSA [ICSPA] 3-BB□MS1L		• P175
200~800 (800~2000)		1000~1000		ICSA [ICSPA] 3-BC□HS1L (BD□HS1L)		• P177 (P185)
300~1000 (1000~2500)		1000~1000		ICSA [ICSPA] 3-BE□HS1L (BF□HS1L)		• P189 (P197)
1000~2500		1000~1000		ICSA [ICSPA] 3-G1JHS1L		• P213
		1000~1000		ICSA [ICSPA] 3-G2JHS1L		• P219
300~1000 (1000~2500)		1000~1000		ICSA [ICSPA] 3-BE□HS1L (BF□HS1L)		• P189 (P197)
1000~2500		1000~1000		ICSA [ICSPA] 3-G1JHS1L		• P213
		1000~1000		ICSA [ICSPA] 3-G2JHS1L		• P219

**Notes on Catalog Specifications****Speed**

**"Speed" refers to the specified speed at which the actuator slider will move. The slider accelerates from a stationary state, and once the specified speed is reached it will maintain that speed until the specified position (immediately before the target position), where it will begin decelerating to stop at the target position.**

**< Caution >**

- ① With all Cartesian robot models, the maximum speed will not change even when the load placed on the slider is changed.
- ② The time needed to reach the specified speed will vary according to the acceleration (deceleration).
- ③ If the travel distance is short, the specified speed may not be reached.
- ④ With a long-stroke axis, the maximum speed will drop to avoid reaching a dangerous speed.  
(If you are using a 600 or longer stroke, check the maximum speed for the applicable stroke.)
- ⑤ When calculating the travel time, consider acceleration, deceleration and stabilization periods in addition to the travel time at the specified speed. (Refer to pages 39 and 40 for the method to calculate travel time.)
- ⑥ Speed can be set in increments of 1 mm/sec in a program.

**Acceleration/Deceleration**

**"Acceleration" refers to the rate of change of speed when the speed rises from zero (stationary state) to the specified speed.**

**"Deceleration" refers to the rate of change of speed when the specified speed drops to zero (stationary state).**

**< Caution >**

- ① Increasing the acceleration (deceleration) will shorten the duration the actuator accelerates (decelerates) and decrease the travel time. However, doing so will also cause rapid acceleration (deceleration), resulting in increased shock.
- ② The load capacity of each type assumes operation at the rated acceleration and maximum speed.  
(The rated acceleration is 0.3 G for the standard type and 0.15 G when the lead is 4 or 5 mm.)
- ③ The ICSA2/ICSPA2 supports a maximum acceleration of 1.0 G.  
The load capacity will decrease when the specified acceleration is increased beyond the rated acceleration.  
For the load capacity at a raised acceleration, refer to the table of load capacity by acceleration corresponding to each actuator type.
- ④ Acceleration can be set (specified) in increments of 0.01 G for each position movement in a program.

**Positioning Repeatability**

**"Positioning repeatability" refers to the positioning accuracy of repeated movements to a pre-stored position.**

**This is not the same as "absolute positioning accuracy," so exercise caution.**

**Home**

**The home is set on the motor side for the standard specification, or on the counter-motor side for the reversed-home specification.**

**< Caution >**

- The incremental actuator always requires homing every time the power is reconnected. (Homing is not required for the absolute type even after reconnecting the power.)
- During homing the slider (or rod or arm) will move to the mechanical end before reversing, so be careful to prevent contact with surrounding parts.
- Note that changing the home position from the standard to reverse homing specification will require the actuator to be returned to IAI for adjustment.

**Duty**

**IAI recommends that our actuators be used at a duty of 50% or less as a guideline in view of the relationship of service life and accuracy.**

$$\text{Duty (\%)} = \frac{\text{Acceleration / Deceleration Time}}{\text{Motion time + Inactivity}} \times 100$$

# Options

If the creep sensor (C) or home limit switch (L) is specified, a sensor cover will be provided on the side face of each axis. Therefore, be careful to prevent contact between each cover and peripheral equipment.

As a rule, a sensor cover is installed on the inside of the X-axis (Y-axis overhung direction), or the top side of the Y-axis. The installation position on the Z-axis will vary depending on the configuration pattern.

With a single-axis robot, the option codes will change when the sensor installation position is reversed (opposite side specification). With a Cartesian robot, however, the option codes need not be changed (only C and L are available).

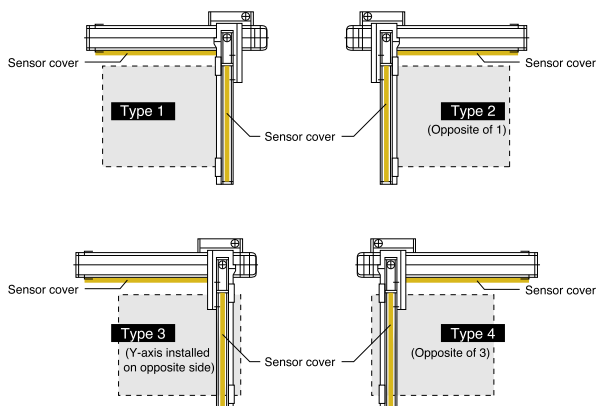

## [ICSA2/ICSPA2]

\* In the standard specification the creep sensor (C) and home limit switch (L) are installed on the right side as viewed from the motor.

Configuration type	Configuration direction	X-axis installation side	Y-axis installation side	Z-axis installation side
<b>XYB</b>	<b>1</b>	Opposite side	Opposite side	—
	<b>2</b>	Standard	Standard	—
	<b>3</b>	Opposite side	Standard	—
	<b>4</b>	Standard	Opposite side	—
<b>XYS</b>	<b>1</b>	Opposite side	Standard	—
	<b>2</b>	Standard	Opposite side	—
	<b>3</b>	Opposite side	Opposite side	—
	<b>4</b>	Standard	Standard	—
<b>XZ</b>		Opposite side	—	Opposite side
<b>YZ</b>		—	Standard	Opposite side
<b>XYG</b>		Opposite side	Opposite side	—

# Cartesian Robot Series Explanation of Model Specification Items

Cartesian robot series features two-axes and three-axes.

Refer to the right page for the explanation of each model specification item.

The selection range for each item will vary depending on the actuator type. For details, refer to the page corresponding to each actuator type.

Number of axes	(1) Series	(2) Type	(3) Encoder type	(4)		(5)		(6)		(7) Applicable controller	(8) Cable length	(9) Cable management between axis 1 and 2	(10) Cable management between axis 2 and 3
				Axis 1 (X-axis, Z-axis)		Axis 2 (X-axis, Z-axis)		Axis 3 (Z-axis)					
				Stroke (cm)	Options	Stroke (cm)	Options	Stroke (cm)	Options				
2 axes	ICSA2 ICSPA2	BA□H BA□M BB□H BB□M BC□H BC□M BD□H BE□H BE□M BF□H SA□H SA□M S1C□H S1C□M SA□M S2C□H SG□M ZAH ZAM Z1CH Z1CM Z2CH ZDH ZGH ZHH YAH YAM YCH YCM YGH G1JH G2JH	A I	10 ~ 250	AQ B C L NM RT	10 ~ 120	AQ B C L NM RT		T1	3L 5L	CT SC		
3 axes	ICSA3 ICSPA3	BB□MB□□ BC□HB□□ BC□MB□□ BD□HB□□ BE□HB□□ BE□MB□□ BF□HB□□ G1JHB□□ G2JHB□□ BA□MS1□ BB□HS1□ BB□MS1□ BC□HS□□ BC□MS□□ BD□HS□□ BE□HS□□ BE□MS□□ BF□HS□□ G1JHS□□ G2JHS□□	A I	10 ~ 250	AQ B C L NM RT	10 ~ 120	AQ B C L NM RT	10 ~ 60	AQ B C L NM RT	T1	□L (Custom order)	CT-CT SC-SC (CT-SC)	

\* In the above model names, □ indicates the configuration direction (1 through 4) (refer to page 43).

### (1) Series

Indicate the name of each series.

- ICSA2: ISA Two-axes configuration
- ICSPA2: ISPA Two-axes configuration
- ICSA3: ISA Three-axes configuration
- ICSPA3: ISPA Three-axes configuration

### (2) Type

Indicate the configuration pattern, configuration direction, configuration model and speed type.

Two-Axes Configuration  $\frac{B}{(1)} \frac{B}{(2)} \frac{1}{(3)} \frac{H}{(4)}$  Three-Axes Configuration  $\frac{B}{(1)} \frac{B}{(2)} \frac{1}{(3)} \frac{H}{(4)} \frac{B}{(5)} \frac{1}{(6)} \frac{M}{(7)}$

- (1) XY-axis configuration / component type (\*1) B:XYB Type / S: XYS Type / Z: XZ Type / Y: YZ Type / G: XYG Type
- (2) XY-axis configuration / size type A / B / C / 1C / 2C / D / E / F / G / 1J / 2J
- (3) XY-axis configuration direction (\*2) 1 / 2 / 3 / 4
- (4) XY-axis speed type H: High-speed type / M: Mid-speed type
- (5) Z-axis installation type B: Base mounted / S: Slider mounted
- (6) Z-axis motor output 1: 60W / 2: 100W / 3: 200W
- (7) Z-axis speed type H: High-speed type / M: Mid-speed type / L: Low-speed type

- (\*1) B(XYB type) and G(XYG type) are available for three-axes configuration.
- (\*2) Specify only when XY-axis configuration type is B(XYB type) or S(XYS type).

### (3) Encoder type

Indicate whether the encoder installed in the actuator is an "absolute type" or "incremental type."

- A: Absolute type Since the current slider position will be retained after the power is turned off, homing is not required when the actuator is powered up.
- I: Incremental type Since the slider position data are cleared when the power is turned off, homing must be performed every time the actuator is powered up.

### (4) Axis 1 details

Indicate the stroke of axis 1 of the two-axes configuration type, as well as an option(s) to be equipped on that axis.

Enter the stroke in centimeters (e.g., 500-mm stroke → 50).

When selecting multiple options, specify them in alphabetical order without a hyphen in between (e.g., AQ seal + Creep sensor + Limit switch + Reversed home specification → AQCLNM).

\* Refer to the explanation of single-axis robot models (page 13) for the details of options.

### (5) Axis 2 details

Indicate the stroke of axis 2 of the two-axes configuration type, as well as an option(s) to be equipped on that axis. Other details are the same as above.

### (6) Axis 3 details

Indicate the stroke of axis 3 of the three-axes configuration type, as well as an option(s) to be equipped on that axis. Other details are the same as above.

### (7) Applicable controller

Indicate the type of controller to be used with the actuator.  
T1: XSEL-J/K, E-Con, P-Driver  
T2: XSEL-P/Q

### (8) Cable length

Indicate the length of the motor/encoder cable connecting the axis-1 actuator to the controller.  
Two standard lengths of 3L (3 m) and 5L (5 m) are available. You can also specify a different length as a custom order. (Maximum length is 20m)

### (9) Cable management between axis 1 and 2

Indicate the cable management between axis 1 and 2.

SC: Self-standing cable  
CT: Cable track

\* The cable management between axis 1 and 2 for types below are available in cable track (CT).

BD□H, BF□H, BD□HB□□, BF□HB□□,  
G1JHB□□, G2JHB□□, BD□HS□□,  
BF□HS□□, G1JHS□□, G2JHS□□

### (10) Cable management between axis 2 and 3

Indicate the cable management from axis 2 to axis 3.

SC: Self-standing cable  
CT: Cable track

\* The cable management between axis 2 and 3 is basically the same as that between axis 1 and 2 except the types listed to the left.

**Two-Axes Configuration**

**XYB type**

- Affix the actuators using the through holes provided on the bottom surface of the X-axis.
- BA□H, BA□M :  $\varnothing 7$  (P15 ISA-SXM Refer to the bottom plan view.)
- BB□H, BB□M :  $\varnothing 9$  (P18 ISA-MXM Refer to the bottom plan view.)
- BC□H, BC□M :  $\varnothing 9$  (P19 ISA-MXM Refer to the bottom plan view.)
- BD□H, :  $\varnothing 9$  (P20 ISA-MXMX Refer to the bottom plan view.)
- BE□H, BE□M :  $\varnothing 9$  (P26 ISA-LXM Refer to the bottom plan view.)
- BF□H, :  $\varnothing 9$  (P28 ISA-LXMX Refer to the bottom plan view.)

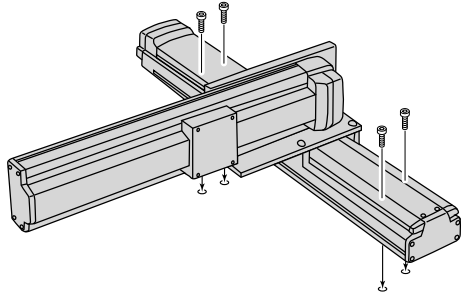

**XYs type**

- Affix the actuators using the through holes provided on the bottom surface of the X-axis.
- SA□H, SA□M :  $\varnothing 7$  (P15 ISA-SXM Refer to the bottom plan view.)
- S1C□H, S1C□M:  $\varnothing 9$  (P18 ISA-MXM Refer to the bottom plan view.)
- S2C□H :  $\varnothing 9$  (P19 ISA-MXM Refer to the bottom plan view.)

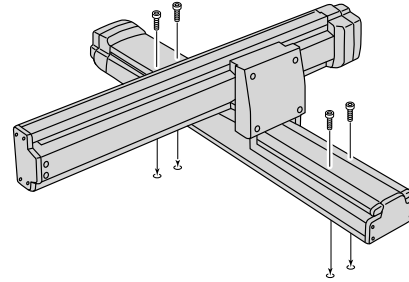

**XZ type**

- Affix the actuators using the through holes provided on the bottom surface of the X-axis.
- ZAH, ZAM :  $\varnothing 7$  (P15 ISA-SXM Refer to the bottom plan view.)
- Z1CH, Z1CM:  $\varnothing 9$  (P18 ISA-MXM Refer to the bottom plan view.)
- Z2CH :  $\varnothing 9$  (P19 ISA-MXM Refer to the bottom plan view.)
- ZDH, :  $\varnothing 9$  (P20 ISA-MXMX Refer to the bottom plan view.)
- ZGH :  $\varnothing 9$  (P26 ISA-LXM Refer to the bottom plan view.)
- ZHH :  $\varnothing 9$  (P28 ISA-LXMX Refer to the bottom plan view.)

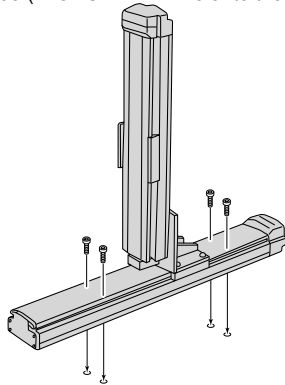

**YZ type**

- Affix the actuators using the threaded holes provided on the bottom surface of the actuator.
- YAH, YAM : M6 (P16 ISA-SYM Refer to the bottom plan view.)
- YCH, YCM : M8 (P22 ISA-MYM Refer to the bottom plan view.)
- YGH : M8 (P32 ISA-LYM Refer to the bottom plan view.)

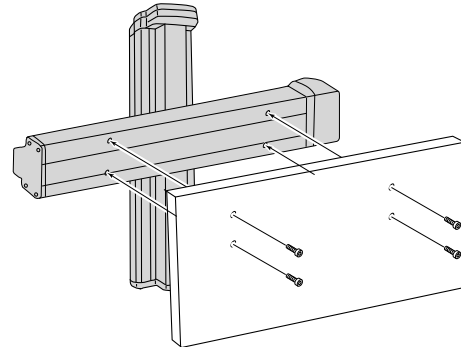

**XYG type**

- Affix the actuators using the through holes provided on the bottom surface of the X-axis (driving shaft / driven shaft).
- G1JH (Driving shaft) :  $\varnothing 9$  (P30 ISA-LXUWX Refer to the bottom plan view.)  
(Driven shaft) :  $\varnothing 7$  (P15 ISA-SXM Refer to the bottom plan view.)
- G2JH (Driving shaft) :  $\varnothing 9$  (P30 ISA-LXUWX Refer to the bottom plan view.)  
(Driven shaft) :  $\varnothing 7$  (P15 ISA-SXM Refer to the bottom plan view.)

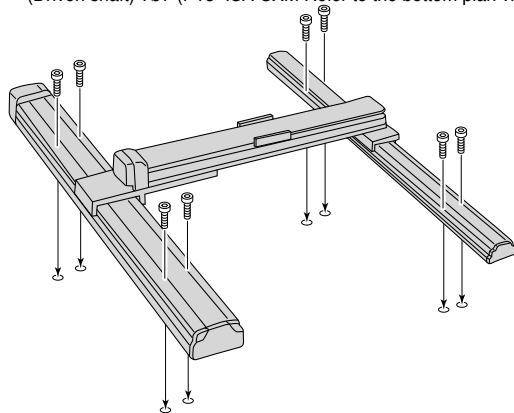



Three-Axes Configuration

XYB+Z Axis type

- Affix the actuators using the through holes provided on the bottom surface of the X-axis.
- BA□MS□□ : ø7 (P15 ISA-SXM Refer to the bottom plan view.)
- BB□□□□□ : ø9 (P18 ISA-MXM Refer to the bottom plan view.)
- BC□□□□□ : ø9 (P19 ISA-MXM Refer to the bottom plan view.)
- BD□□□□□ : ø9 (P20 ISA-MXM Refer to the bottom plan view.)
- BE□□□□□ : ø9 (P26 ISA-LXM Refer to the bottom plan view.)
- BF□□□□□ : ø9 (P28 ISA-LXM Refer to the bottom plan view.)

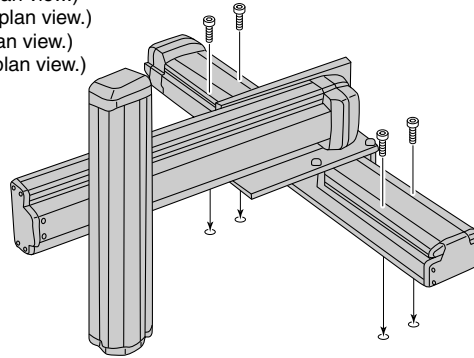

XYG+Z Axis type

- Affix the actuators using the through holes provided on the bottom surface of the X-axis (driving shaft / driven shaft).
- G1JH□□□ (Driving shaft) : ø9 (P30 ISA-LXUWX Refer to the bottom plan view.)  
(Driven shaft) : ø7 (P15 ISA-SXM Refer to the bottom plan view.)
- G2JH□□□ (Driving shaft) : ø9 (P30 ISA-LXUWX Refer to the bottom plan view.)  
(Driven shaft) : ø7 (P15 ISA-SXM Refer to the bottom plan view.)

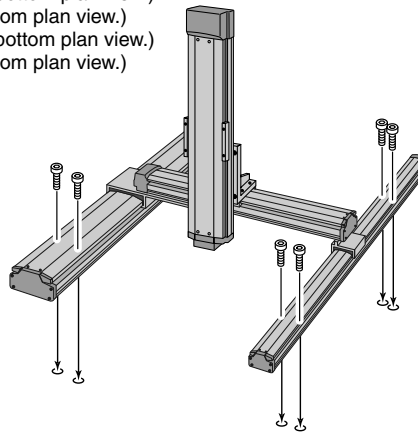

## Actuator

ICSA2 Series  
ICSPA2 Series  
ICSA3 Series  
ICSPA3 Series



## Controller

X-SEL

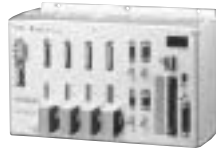

(Refer to page 241)

P-Driver



(Refer to page 234)

\* Operating with P-Driver requires as many P-Driver controller as the number of axis to operate.

## Options

Teaching pendant  
<IA-T-X>

PC Software  
<IA-101-X-MW>  
<IA-101-X-CW>

(Refer to page 251)

PC Software  
<PDR-101-MW>

(Refer to page 239)

Motor Cable  
Encoder Cable



<b>ICSA3-BA MB1</b>		Cartesian Robot: X-Y-Z 3-Axes Configuration Z-Axis Base Mount Type	
<b>ICSPA3-BA MB1</b>		Cartesian Robot: X-Y-Z 3-Axes Configuration Z-Axis Base Mount Type High-Precision Specification	
Type	XYB + Z-Axis Base Mount Type	Stroke	X-axis: 100-600mm Y-axis: 100-400mm Z-axis: 100-300mm
Load capacity	13kg ~ 1.7kg		
Model specification items	Series	Type	Encoder type
(Example)	ICSA3 (ICSPA3)	-BA1MB1M-	A
			- 60AQL - 40AQL - 30BL - T1 - 5L - SC - SC

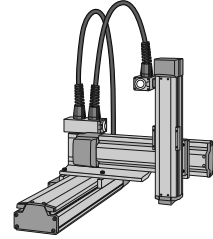

\* Refer to page 51 for the details of model specification items.

**Models/Specifications**

\* [ ] is for the high-precision specification.

Encoder Type	XY-axis configuration direction (*1)	Z-axis type (*2)	Model
Absolute	1	H	ICSA3 [ICSPA3] -BA1MB1H-A- [1] - [2] - [3] -B-T1- [4] - [5]
		M	ICSA3 [ICSPA3] -BA1MB1M-A- [1] - [2] - [3] -B-T1- [4] - [5]
		L	ICSA3 [ICSPA3] -BA1MB1L-A- [1] - [2] - [3] -B-T1- [4] - [5]
	2	H	ICSA3 [ICSPA3] -BA2MB1H-A- [1] - [2] - [3] -B-T1- [4] - [5]
		M	ICSA3 [ICSPA3] -BA2MB1M-A- [1] - [2] - [3] -B-T1- [4] - [5]
		L	ICSA3 [ICSPA3] -BA2MB1L-A- [1] - [2] - [3] -B-T1- [4] - [5]
	3	H	ICSA3 [ICSPA3] -BA3MB1H-A- [1] - [2] - [3] -B-T1- [4] - [5]
		M	ICSA3 [ICSPA3] -BA3MB1M-A- [1] - [2] - [3] -B-T1- [4] - [5]
		L	ICSA3 [ICSPA3] -BA3MB1L-A- [1] - [2] - [3] -B-T1- [4] - [5]
	4	H	ICSA3 [ICSPA3] -BA4MB1H-A- [1] - [2] - [3] -B-T1- [4] - [5]
		M	ICSA3 [ICSPA3] -BA4MB1M-A- [1] - [2] - [3] -B-T1- [4] - [5]
		L	ICSA3 [ICSPA3] -BA4MB1L-A- [1] - [2] - [3] -B-T1- [4] - [5]
Incremental	1	H	ICSA3 [ICSPA3] -BA1MB1H-I- [1] - [2] - [3] -B-T1- [4] - [5]
		M	ICSA3 [ICSPA3] -BA1MB1M-I- [1] - [2] - [3] -B-T1- [4] - [5]
		L	ICSA3 [ICSPA3] -BA1MB1L-I- [1] - [2] - [3] -B-T1- [4] - [5]
	2	H	ICSA3 [ICSPA3] -BA2MB1H-I- [1] - [2] - [3] -B-T1- [4] - [5]
		M	ICSA3 [ICSPA3] -BA2MB1M-I- [1] - [2] - [3] -B-T1- [4] - [5]
		L	ICSA3 [ICSPA3] -BA2MB1L-I- [1] - [2] - [3] -B-T1- [4] - [5]
	3	H	ICSA3 [ICSPA3] -BA3MB1H-I- [1] - [2] - [3] -B-T1- [4] - [5]
		M	ICSA3 [ICSPA3] -BA3MB1M-I- [1] - [2] - [3] -B-T1- [4] - [5]
		L	ICSA3 [ICSPA3] -BA3MB1L-I- [1] - [2] - [3] -B-T1- [4] - [5]
	4	H	ICSA3 [ICSPA3] -BA4MB1H-I- [1] - [2] - [3] -B-T1- [4] - [5]
		M	ICSA3 [ICSPA3] -BA4MB1M-I- [1] - [2] - [3] -B-T1- [4] - [5]
		L	ICSA3 [ICSPA3] -BA4MB1L-I- [1] - [2] - [3] -B-T1- [4] - [5]

\*1: Refer to the figure below for XY-axis configuration direction.  
\*2: The load capacity and the maximum speed may vary depending on the type of Z-axis.  
Note: T1 in the above models will be T2 when operated with XSEL-P/G type.

**Explanation of Model Code**

Number	Contents	Specification
[1]	X-axis stroke (Note 1)	10 : 100mm ~ 60 : 600mm
[2]	Y-axis stroke (Note 1)	10 : 100mm ~ 40 : 400mm
[3]	Z-axis stroke (Note 1)	10 : 100mm ~ 30 : 300mm
[4]	Cable length (Note 2)	3L : 3m 5L : 5m
[5]	Y-axis/ Z-axis cable management	SC-SC : Self-standing cable CT-CT : Cable track

\* The above explains the Models/Specifications chart to the left.

**Options**

Please add the option codes at the end of each stroke of the axis. When adding multiple options, put together in alphabetic order.

Name	Code	Page
AQ seal	AQ	→P13
Brake	B	→P13
Creep sensor	C	→P13
Home limit switch	L	→P14
Reversed-home specification	NM	→P14
Guide with ball-retaining mechanism	RT	→P14

**Configuration Direction**

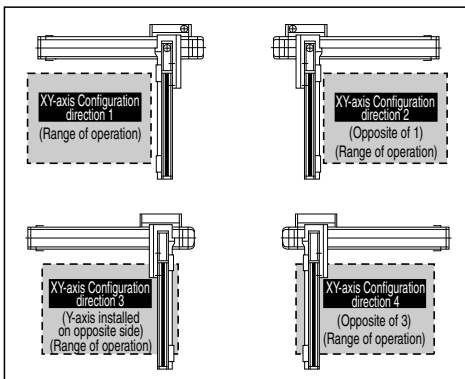

**Common Specifications**

\* [ ] is for the high-precision specification.

Drive system	Ball screw, rolled C10 [equivalent to rolled C5]
Positioning repeatability	±0.02mm [±0.01mm]
Backlash	0.05mm or less [0.02mm or less]
Guide	Integrated with base
Base	Material: Aluminum with white alumite treatment
X-axis motor output / lead	60W / 8mm
Y-axis motor output / lead	60W / 8mm
Z-axis motor output / lead	60W / 16mm (H), 8mm (M), 4mm (L)

**Applicable Controller Specifications**

Refer to page 65 for System Configuration.

**Axis Configuration**

\* [ ] is for the high-precision specification.

Axis Type	Model	Page
X-axis	ISA[ISPA]-SXM-[ ]-60-8-(Stroke)-T1	→P15
Y-axis	ISA[ISPA]-SYM-[ ]-60-8-(Stroke)-T1	→P16
Z-axis	ISA[ISPA]-SXM-[ ]-60-16/8/4-(Stroke)-T1-B	→P15

\*In the above model name, [ ] indicates encoder type A (absolute) or I (incremental).

**Caution**

(Note 1) The stroke in the model is specified in cm (centimeters).  
 (Note 2) The cable length measures from the X-axis connector box to the controller. The standard lengths are 3m and 5m, but other lengths can also be specified in meters. The maximum length is 20m.  
 (Note 3) The rated acceleration is 0.3G. Increasing the acceleration will result in lower load capacity.  
 (Note 4) Please note that a longer stroke will result in a lower maximum speed.

\* For other points to note, please refer to page 49.

**ICSA3 [ICSPA3] -BA□MB1□**

Single-Axis Robots

Cartesian Robots

Controllers

**Load Capacity (kg) (Note3)**

**BA□MB1H**

		Y-axis stroke			
		100	200	300	400
Z-axis stroke	100	3.0		2.9	
	200	3.0		2.3	
	300	3.0		1.7	

**BA□MB1M**

		Y-axis stroke			
		100	200	300	400
Z-axis stroke	100	6.0		2.9	
	200	6.0		2.3	
	300	6.0	5.7	1.7	

**BA□MB1L**

		Y-axis stroke			
		100	200	300	400
Z-axis stroke	100	13.0	11.4	6.9	2.9
	200	12.4	10.8	6.3	2.3
	300	11.8	10.2	5.7	1.7

**Maximum Speed by Stroke (mm/sec) (Note4)**

**BA□MB1H**

	Stroke					
	100	200	300	400	500	600
X-axis	400					
Y-axis	400		-	-	-	-
Z-axis	800		-	-	-	-

**BA□MB1M**

	Stroke					
	100	200	300	400	500	600
X-axis	400					
Y-axis	400		-	-	-	-
Z-axis	400		-	-	-	-

**BA□MB1L**

	Stroke					
	100	200	300	400	500	600
X-axis	400					
Y-axis	400		-	-	-	-
Z-axis	200		-	-	-	-

**Dimensions** \* The dimension below is for XY-axis Configuration direction 1.

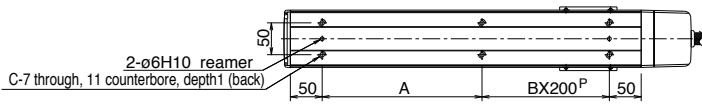
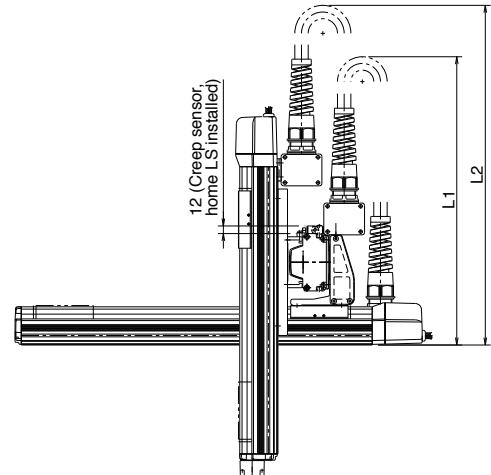
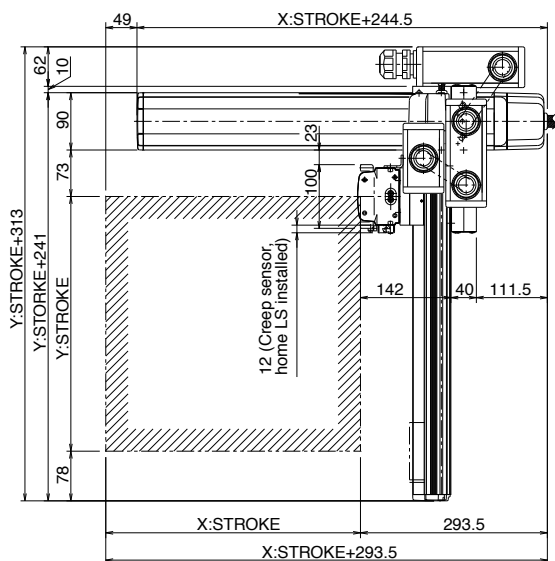
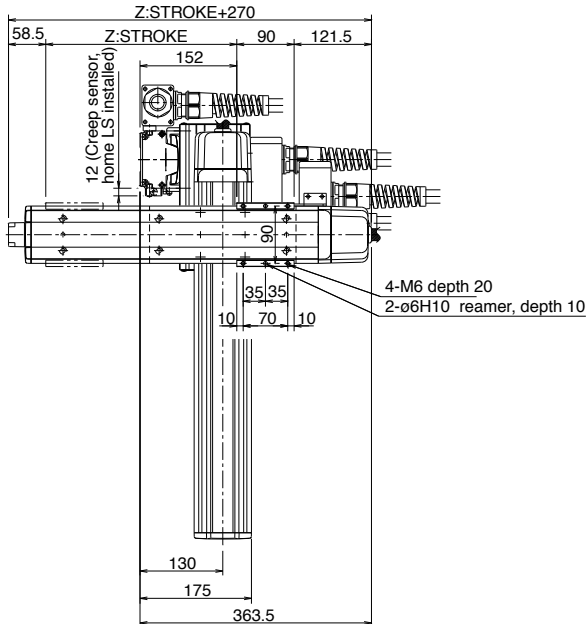

\* The configuration position in the figure is home position. To change the home position, indicate NM in the option. Note that changing the home direction will require the actuator to be returned to IAI for adjustment.

X stroke	100	200	300	400	500	600
L1	(500)	(550)	(600)	(650)	(700)	(750)
A	151	251	151	251	151	251
B	0	0	1	1	2	2
C	4	4	6	6	8	8

Y stroke	100	200	300	400
L2	(590)	(640)	(690)	(740)

<b>ICSA3-BB</b> <input type="checkbox"/> <b>HB1</b> <input type="checkbox"/>		Cartesian Robot: X-Y-Z 3-Axes Configuration Z-Axis Base Mount Type
<b>ICSPA3-BB</b> <input type="checkbox"/> <b>HB1</b> <input type="checkbox"/>		Cartesian Robot: X-Y-Z 3-Axes Configuration Z-Axis Base Mount Type High-Precision Specification
Type	XYB + Z-Axis Base Mount Type	Stroke X-axis: 200-800mm Y-axis: 100-400mm Z-axis: 100-300mm
Load capacity	7.1kg ~ 3kg	
Model specification items	Series	Type Encoder type X-axis stroke + options Y-axis stroke + options Z-axis stroke + options Applicable controller Cable length Cable management
(Example)	ICSA3 (ICSPA3)	- BB1HB1M - A - 70AQL - 40AQL - 30BL - T1 - 5L - SC - SC

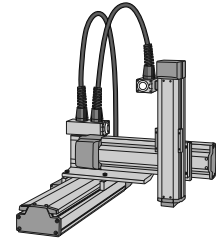

\* Refer to page 51 for the details of model specification items.

**Models/Specifications** \* [ ] is for the high-precision specification.

Encoder Type	XY-axis configuration direction (*1)	Z-axis type (*2)	Model
Absolute	1	H	ICSA3 [ICSPA3] - BB1HB1H-A- [1]-[2]-[3]-B-T1-[4]-[5]
		M	ICSA3 [ICSPA3] - BB1HB1M-A- [1]-[2]-[3]-B-T1-[4]-[5]
		L	ICSA3 [ICSPA3] - BB1HB1L-A- [1]-[2]-[3]-B-T1-[4]-[5]
	2	H	ICSA3 [ICSPA3] - BB2HB1H-A- [1]-[2]-[3]-B-T1-[4]-[5]
		M	ICSA3 [ICSPA3] - BB2HB1M-A- [1]-[2]-[3]-B-T1-[4]-[5]
		L	ICSA3 [ICSPA3] - BB2HB1L-A- [1]-[2]-[3]-B-T1-[4]-[5]
	3	H	ICSA3 [ICSPA3] - BB3HB1H-A- [1]-[2]-[3]-B-T1-[4]-[5]
		M	ICSA3 [ICSPA3] - BB3HB1M-A- [1]-[2]-[3]-B-T1-[4]-[5]
		L	ICSA3 [ICSPA3] - BB3HB1L-A- [1]-[2]-[3]-B-T1-[4]-[5]
	4	H	ICSA3 [ICSPA3] - BB4HB1H-A- [1]-[2]-[3]-B-T1-[4]-[5]
		M	ICSA3 [ICSPA3] - BB4HB1M-A- [1]-[2]-[3]-B-T1-[4]-[5]
		L	ICSA3 [ICSPA3] - BB4HB1L-A- [1]-[2]-[3]-B-T1-[4]-[5]
Incremental	1	H	ICSA3 [ICSPA3] - BB1HB1H-I- [1]-[2]-[3]-B-T1-[4]-[5]
		M	ICSA3 [ICSPA3] - BB1HB1M-I- [1]-[2]-[3]-B-T1-[4]-[5]
		L	ICSA3 [ICSPA3] - BB1HB1L-I- [1]-[2]-[3]-B-T1-[4]-[5]
	2	H	ICSA3 [ICSPA3] - BB2HB1H-I- [1]-[2]-[3]-B-T1-[4]-[5]
		M	ICSA3 [ICSPA3] - BB2HB1M-I- [1]-[2]-[3]-B-T1-[4]-[5]
		L	ICSA3 [ICSPA3] - BB2HB1L-I- [1]-[2]-[3]-B-T1-[4]-[5]
	3	H	ICSA3 [ICSPA3] - BB3HB1H-I- [1]-[2]-[3]-B-T1-[4]-[5]
		M	ICSA3 [ICSPA3] - BB3HB1M-I- [1]-[2]-[3]-B-T1-[4]-[5]
		L	ICSA3 [ICSPA3] - BB3HB1L-I- [1]-[2]-[3]-B-T1-[4]-[5]
	4	H	ICSA3 [ICSPA3] - BB4HB1H-I- [1]-[2]-[3]-B-T1-[4]-[5]
		M	ICSA3 [ICSPA3] - BB4HB1M-I- [1]-[2]-[3]-B-T1-[4]-[5]
		L	ICSA3 [ICSPA3] - BB4HB1L-I- [1]-[2]-[3]-B-T1-[4]-[5]

\*1: Refer to the figure below for XY-axis configuration direction.  
\*2: The load capacity and the maximum speed may vary depending on the type of Z-axis.  
Note: T1 in the above models will be T2 when operated with XSEL-P/G type.

**Explanation of Model Code**

Number	Contents	Specification
①	X-axis stroke (Note 1)	20 : 200mm ~ 80 : 800mm
②	Y-axis stroke (Note 1)	10 : 100mm ~ 40 : 400mm
③	Z-axis stroke (Note 1)	10 : 100mm ~ 30 : 300mm
④	Cable length (Note 2)	3L : 3m 5L : 5m
⑤	Y-axis/ Z-axis cable management	SC-SC : Self-standing cable CT-CT : Cable track

\* The above explains the Models/Specifications chart to the left.

**Options**

Please add the option codes at the end of each stroke of the axis.  
When adding multiple options, put together in alphabetic order.

Name	Code	Page
AQ seal	AQ	→P13
Brake	B	→P13
Creep sensor	C	→P13
Home limit switch	L	→P14
Reversed-home specification	NM	→P14
Guide with ball-retaining mechanism	RT	→P14

**Configuration Direction**

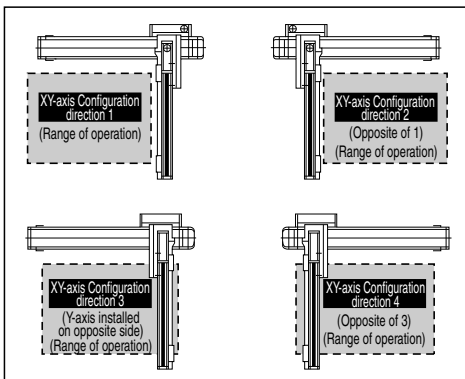

**Common Specifications** \* [ ] is for the high-precision specification.

Drive system	Ball screw, rolled C10 [equivalent to rolled C5]
Positioning repeatability	±0.02mm [±0.01mm]
Backlash	0.05mm or less [0.02mm or less]
Guide	Integrated with base
Base	Material: Aluminum with white alumite treatment
X-axis motor output / lead	100W / 20mm
Y-axis motor output / lead	60W / 16mm
Z-axis motor output / lead	60W / 16mm (H), 8mm (M), 4mm (L)

**Applicable Controller Specifications**

Refer to page 65 for System Configuration.

**Axis Configuration** \* [ ] is for the high-precision specification.

Axis Type	Model	Page
X-axis	ISA[ISPA]-MXM-□-100-20-(Stroke)-T1	→P18
Y-axis	ISA[ISPA]-SYM-□-60-16-(Stroke)-T1	→P16
Z-axis	ISA[ISPA]-SXM-□-60-16/8/4-(Stroke)-T1-B	→P15

\*In the above model name, □ indicates encoder type A (absolute) or I (incremental).

**Caution**

(Note 1) The stroke in the model is specified in cm (centimeters).  
 (Note 2) The cable length measures from the X-axis connector box to the controller. The standard lengths are 3m and 5m, but other lengths can also be specified in meters. The maximum length is 20m.  
 (Note 3) The rated acceleration is 0.3G. Increasing the acceleration will result in lower load capacity.  
 (Note 4) Please note that a longer stroke will result in a lower maximum speed.

\* For other points to note, please refer to page 49.

ICSA3 [ICSPA3] - BB□HB1□

**Load Capacity (kg) (Note3)**

■ BB□HB1H

		Y-axis stroke			
		100	200	300	400
Z-axis stroke	100	3.0			
	200	3.0			
	300	3.0			

■ BB□HB1M

		Y-axis stroke			
		100	200	300	400
Z-axis stroke	100	6.0			5.9
	200	6.0			5.3
	300	5.6		5.4	4.7

■ BB□HB1L

		Y-axis stroke			
		100	200	300	400
Z-axis stroke	100	7.1	6.9	6.2	
	200	6.1	5.9	5.2	
	300	5.6	5.4	4.7	

**Maximum Speed by Stroke (mm/sec) (Note4)**

■ BB□HB1H

	Stroke								
	100	200	300	400	500	600	700	800	
X-axis	-	1000							795
Y-axis	800		-	-	-	-	-	-	
Z-axis	800	-	-	-	-	-	-	-	

■ BB□HB1M

	Stroke								
	100	200	300	400	500	600	700	800	
X-axis	-	1000							795
Y-axis	800		-	-	-	-	-	-	
Z-axis	400	-	-	-	-	-	-	-	

■ BB□HB1L

	Stroke								
	100	200	300	400	500	600	700	800	
X-axis	-	1000							795
Y-axis	800		-	-	-	-	-	-	
Z-axis	200	-	-	-	-	-	-	-	

**Dimensions**

\* The dimension below is for XY-axis Configuration direction 1.

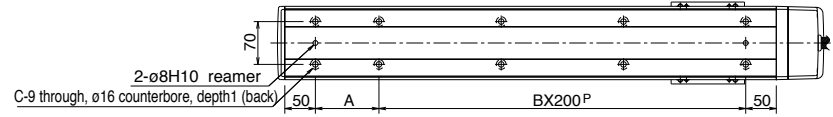
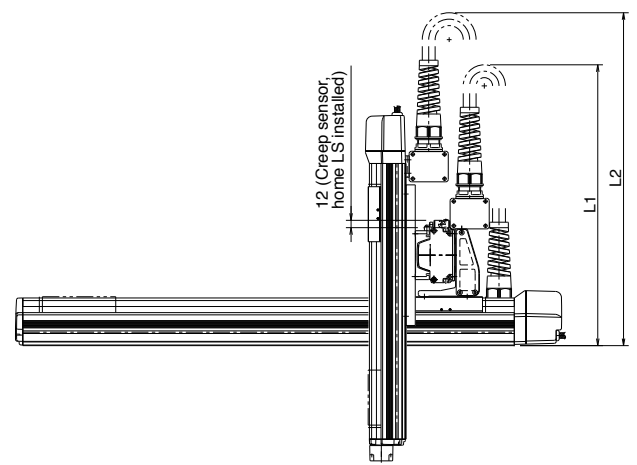
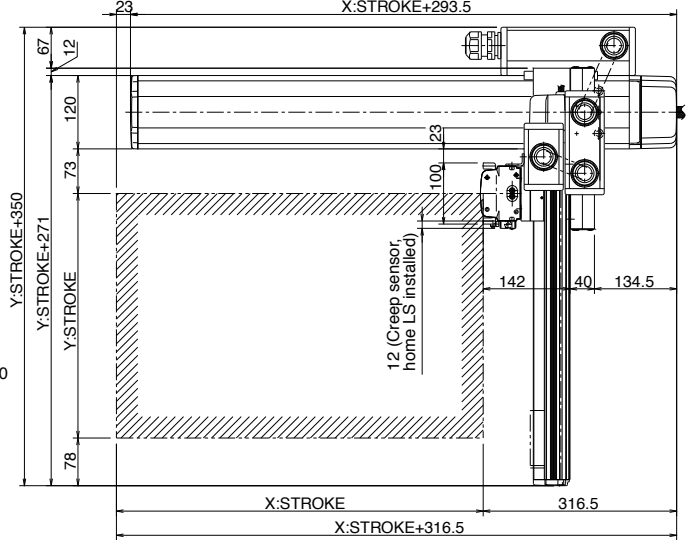
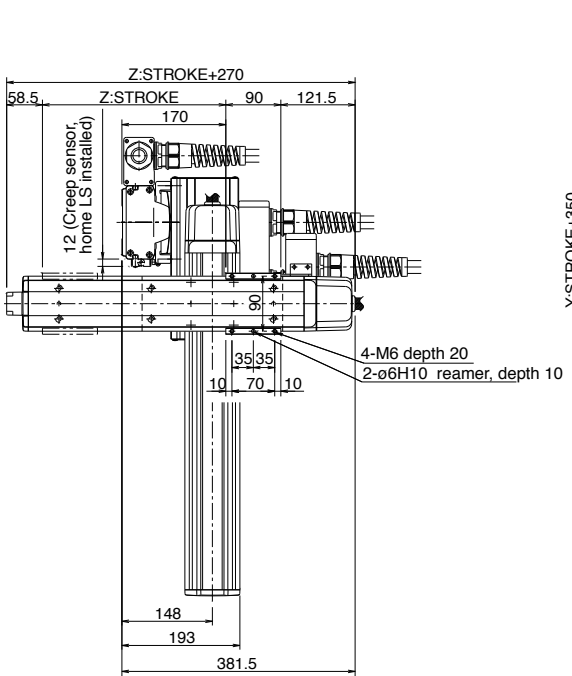

\* The configuration position in the figure is home position. To change the home position, indicate NM in the option. Note that changing the home direction will require the actuator to be returned to IAI for adjustment.

X stroke	200	300	400	500	600	700	800
L1	(550)	(600)	(650)	(700)	(750)	(800)	(850)
A	104	204	104	204	104	204	104
B	1	1	2	2	3	3	4
C	6	6	8	8	10	10	12

Y stroke	100	200	300	400
L2	(600)	(650)	(700)	(750)

<b>ICSA3-BB MB1</b>		Cartesian Robot: X-Y-Z 3-Axes Configuration Z-Axis Base Mount Type	
<b>ICSPA3-BB MB1</b>		Cartesian Robot: X-Y-Z 3-Axes Configuration Z-Axis Base Mount Type High-Precision Specification	
Type	XYB + Z-Axis Base Mount Type	Stroke	X-axis: 200-800mm Y-axis: 100-400mm Z-axis: 100-300mm
Load capacity	14kg ~ 3kg		
Model specification items	Series	Type	Encoder type
(Example)	ICSA3 (ICSPA3)	-BB1MB1M-	A
			- 70AQL - 40AQL - 30BL - T1 - 5L - SC - SC

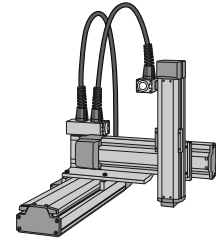

\* Refer to page 51 for the details of model specification items.

**Models/Specifications** \* [ ] is for the high-precision specification.

Encoder Type	XY-axis configuration direction (*1)	Z-axis type (*2)	Model
Absolute	1	H	ICSA3 [ICSPA3] -BB1MB1H-A-[1]-[2]-[3]-B-T1-[4]-[5]
		M	ICSA3 [ICSPA3] -BB1MB1M-A-[1]-[2]-[3]-B-T1-[4]-[5]
		L	ICSA3 [ICSPA3] -BB1MB1L-A-[1]-[2]-[3]-B-T1-[4]-[5]
	2	H	ICSA3 [ICSPA3] -BB2MB1H-A-[1]-[2]-[3]-B-T1-[4]-[5]
		M	ICSA3 [ICSPA3] -BB2MB1M-A-[1]-[2]-[3]-B-T1-[4]-[5]
		L	ICSA3 [ICSPA3] -BB2MB1L-A-[1]-[2]-[3]-B-T1-[4]-[5]
	3	H	ICSA3 [ICSPA3] -BB3MB1H-A-[1]-[2]-[3]-B-T1-[4]-[5]
		M	ICSA3 [ICSPA3] -BB3MB1M-A-[1]-[2]-[3]-B-T1-[4]-[5]
		L	ICSA3 [ICSPA3] -BB3MB1L-A-[1]-[2]-[3]-B-T1-[4]-[5]
	4	H	ICSA3 [ICSPA3] -BB4MB1H-A-[1]-[2]-[3]-B-T1-[4]-[5]
		M	ICSA3 [ICSPA3] -BB4MB1M-A-[1]-[2]-[3]-B-T1-[4]-[5]
		L	ICSA3 [ICSPA3] -BB4MB1L-A-[1]-[2]-[3]-B-T1-[4]-[5]
Incremental	1	H	ICSA3 [ICSPA3] -BB1MB1H-I-[1]-[2]-[3]-B-T1-[4]-[5]
		M	ICSA3 [ICSPA3] -BB1MB1M-I-[1]-[2]-[3]-B-T1-[4]-[5]
		L	ICSA3 [ICSPA3] -BB1MB1L-I-[1]-[2]-[3]-B-T1-[4]-[5]
	2	H	ICSA3 [ICSPA3] -BB2MB1H-I-[1]-[2]-[3]-B-T1-[4]-[5]
		M	ICSA3 [ICSPA3] -BB2MB1M-I-[1]-[2]-[3]-B-T1-[4]-[5]
		L	ICSA3 [ICSPA3] -BB2MB1L-I-[1]-[2]-[3]-B-T1-[4]-[5]
	3	H	ICSA3 [ICSPA3] -BB3MB1H-I-[1]-[2]-[3]-B-T1-[4]-[5]
		M	ICSA3 [ICSPA3] -BB3MB1M-I-[1]-[2]-[3]-B-T1-[4]-[5]
		L	ICSA3 [ICSPA3] -BB3MB1L-I-[1]-[2]-[3]-B-T1-[4]-[5]
	4	H	ICSA3 [ICSPA3] -BB4MB1H-I-[1]-[2]-[3]-B-T1-[4]-[5]
		M	ICSA3 [ICSPA3] -BB4MB1M-I-[1]-[2]-[3]-B-T1-[4]-[5]
		L	ICSA3 [ICSPA3] -BB4MB1L-I-[1]-[2]-[3]-B-T1-[4]-[5]

\*1: Refer to the figure below for XY-axis configuration direction.  
\*2: The load capacity and the maximum speed may vary depending on the type of Z-axis.  
Note: T1 in the above models will be T2 when operated with XSEL-P/G type.

**Explanation of Model Code**

Number	Contents	Specification
①	X-axis stroke (Note 1)	20 : 200mm ~ 80 : 800mm
②	Y-axis stroke (Note 1)	10 : 100mm ~ 40 : 400mm
③	Z-axis stroke (Note 1)	10 : 100mm ~ 30 : 300mm
④	Cable length (Note 2)	3L : 3m 5L : 5m
⑤	Y-axis/ Z-axis cable management	SC-SC : Self-standing cable CT-CT : Cable track

\* The above explains the Models/Specifications chart to the left.

**Options**

Please add the option codes at the end of each stroke of the axis.  
When adding multiple options, put together in alphabetic order.

Name	Code	Page
AQ seal	AQ	→P13
Brake	B	→P13
Creep sensor	C	→P13
Home limit switch	L	→P14
Reversed-home specification	NM	→P14
Guide with ball-retaining mechanism	RT	→P14

**Configuration Direction**

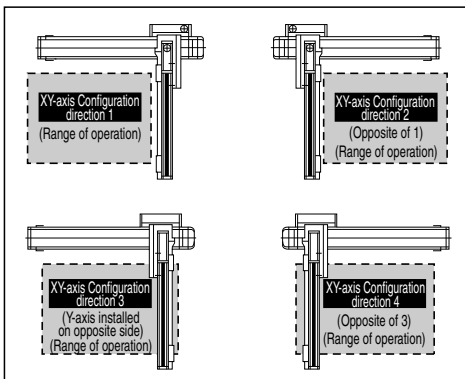

**Common Specifications** \* [ ] is for the high-precision specification.

Drive system	Ball screw, rolled C10 [equivalent to rolled C5]
Positioning repeatability	±0.02mm [±0.01mm]
Backlash	0.05mm or less [0.02mm or less]
Guide	Integrated with base
Base	Material: Aluminum with white alumite treatment
X-axis motor output / lead	100W / 10mm
Y-axis motor output / lead	60W / 8mm
Z-axis motor output / lead	60W / 16mm (H), 8mm (M), 4mm (L)

**Applicable Controller Specifications**

Refer to page 65 for System Configuration.

**Axis Configuration** \* [ ] is for the high-precision specification.

Axis Type	Model	Page
X-axis	ISA[ISPA]-MXM-[ ]-100-10-(Stroke)-T1	→P18
Y-axis	ISA[ISPA]-SYM-[ ]-60-8-(Stroke)-T1	→P16
Z-axis	ISA[ISPA]-SXM-[ ]-60-16/8/4-(Stroke)-T1-B	→P15

\*In the above model name, [ ] indicates encoder type A (absolute) or I (incremental).

**Caution**

(Note 1) The stroke in the model is specified in cm (centimeters).  
 (Note 2) The cable length measures from the X-axis connector box to the controller. The standard lengths are 3m and 5m, but other lengths can also be specified in meters. The maximum length is 20m.  
 (Note 3) The rated acceleration is 0.3G. Increasing the acceleration will result in lower load capacity.  
 (Note 4) Please note that a longer stroke will result in a lower maximum speed.

\* For other points to note, please refer to page 49.



ICSA3 [ICSPA3] -BB□MB1□

**Load Capacity (kg) (Note3)**

■BB□MB1H

		Y-axis stroke			
		100	200	300	400
Z-axis stroke	100	3.0			
	200	3.0			
	300	3.0			

■BB□MB1M

		Y-axis stroke			
		100	200	300	400
Z-axis stroke	100	6.0			
	200	6.0			
	300	6.0			

■BB□MB1L

		Y-axis stroke			
		100	200	300	400
Z-axis stroke	100	14.0			
	200	14.0			
	300	14.0			

**Maximum Speed by Stroke (mm/sec) (Note4)**

■BB□MB1H

	Stroke								
	100	200	300	400	500	600	700	800	
X-axis	-	500				480			380
Y-axis	400			-	-	-	-	-	-
Z-axis	800	-	-	-	-	-	-	-	

■BB□MB1M

	Stroke								
	100	200	300	400	500	600	700	800	
X-axis	-	500				480			380
Y-axis	400			-	-	-	-	-	
Z-axis	400	-	-	-	-	-	-	-	

■BB□MB1L

	Stroke								
	100	200	300	400	500	600	700	800	
X-axis	-	500				480			380
Y-axis	400			-	-	-	-	-	
Z-axis	200	-	-	-	-	-	-	-	

**Dimensions**

\* The dimension below is for XY-axis Configuration direction 1.

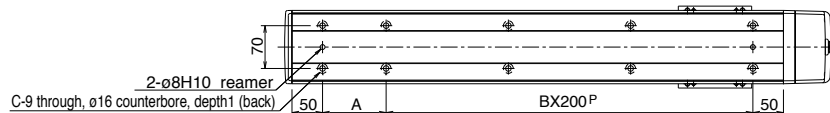
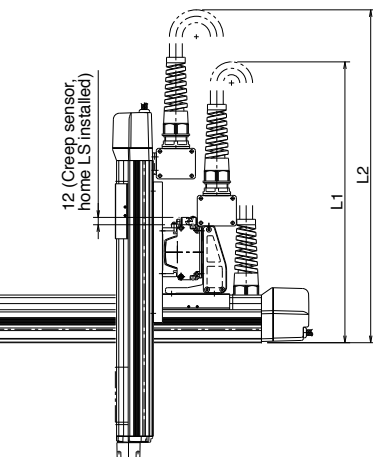
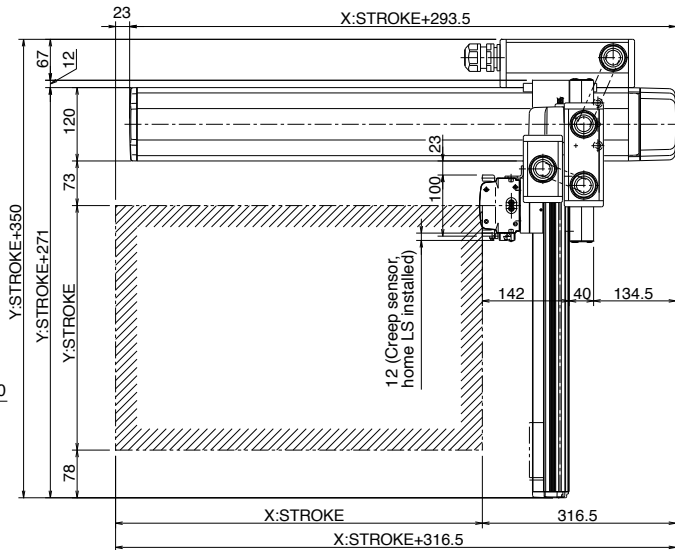
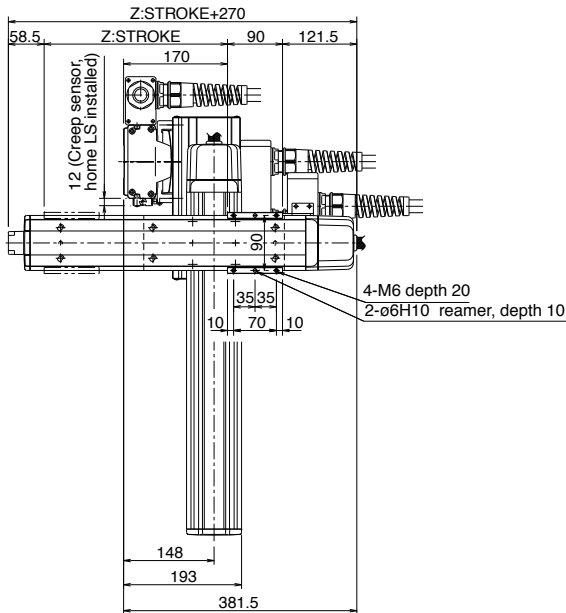

\* The configuration position in the figure is home position. To change the home position, indicate NM in the option. Note that changing the home direction will require the actuator to be returned to IAI for adjustment.

X stroke	200	300	400	500	600	700	800
L1	(550)	(600)	(650)	(700)	(750)	(800)	(850)
A	104	204	104	204	104	204	104
B	1	1	2	2	3	3	4
C	6	6	8	8	10	10	12

Y stroke	100	200	300	400
L2	(600)	(650)	(700)	(750)

<b>ICSA3-BB MB2</b>		Cartesian Robot: X-Y-Z 3-Axes Configuration Z-Axis Base Mount Type	
<b>ICSPA3-BB MB2</b>		Cartesian Robot: X-Y-Z 3-Axes Configuration Z-Axis Base Mount Type High-Precision Specification	
Type	XYB + Z-Axis Base Mount Type	Stroke	X-axis: 200-800mm Y-axis: 100-400mm Z-axis: 100-400mm
		Load capacity	15.9kg ~ 3.5kg
Model specification items	Series	Type	Encoder type
(Example)	ICSA3 (ICSPA3)	BB1MB2M	A
			70AQL - 40AQL - 30BL - T1 - 5L - SC - SC

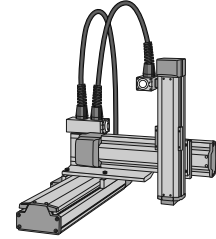

\* Refer to page 51 for the details of model specification items.

**Models/Specifications**

\* [ ] is for the high-precision specification.

Encoder Type	XY-axis configuration direction (*1)	Z-axis type (*2)	Model
Absolute	1	H	ICSA3 [ICSPA3] -BB1MB2H-A-[1]-[2]-[3]-B-T1-[4]-[6]
		M	ICSA3 [ICSPA3] -BB1MB2M-A-[1]-[2]-[3]-B-T1-[4]-[6]
		L	ICSA3 [ICSPA3] -BB1MB2L-A-[1]-[2]-[3]-B-T1-[4]-[6]
	2	H	ICSA3 [ICSPA3] -BB2MB2H-A-[1]-[2]-[3]-B-T1-[4]-[6]
		M	ICSA3 [ICSPA3] -BB2MB2M-A-[1]-[2]-[3]-B-T1-[4]-[6]
		L	ICSA3 [ICSPA3] -BB2MB2L-A-[1]-[2]-[3]-B-T1-[4]-[6]
	3	H	ICSA3 [ICSPA3] -BB3MB2H-A-[1]-[2]-[3]-B-T1-[4]-[6]
		M	ICSA3 [ICSPA3] -BB3MB2M-A-[1]-[2]-[3]-B-T1-[4]-[6]
		L	ICSA3 [ICSPA3] -BB3MB2L-A-[1]-[2]-[3]-B-T1-[4]-[6]
	4	H	ICSA3 [ICSPA3] -BB4MB2H-A-[1]-[2]-[3]-B-T1-[4]-[6]
		M	ICSA3 [ICSPA3] -BB4MB2M-A-[1]-[2]-[3]-B-T1-[4]-[6]
		L	ICSA3 [ICSPA3] -BB4MB2L-A-[1]-[2]-[3]-B-T1-[4]-[6]
Incremental	1	H	ICSA3 [ICSPA3] -BB1MB2H-I-[1]-[2]-[3]-B-T1-[4]-[6]
		M	ICSA3 [ICSPA3] -BB1MB2M-I-[1]-[2]-[3]-B-T1-[4]-[6]
		L	ICSA3 [ICSPA3] -BB1MB2L-I-[1]-[2]-[3]-B-T1-[4]-[6]
	2	H	ICSA3 [ICSPA3] -BB2MB2H-I-[1]-[2]-[3]-B-T1-[4]-[6]
		M	ICSA3 [ICSPA3] -BB2MB2M-I-[1]-[2]-[3]-B-T1-[4]-[6]
		L	ICSA3 [ICSPA3] -BB2MB2L-I-[1]-[2]-[3]-B-T1-[4]-[6]
	3	H	ICSA3 [ICSPA3] -BB3MB2H-I-[1]-[2]-[3]-B-T1-[4]-[6]
		M	ICSA3 [ICSPA3] -BB3MB2M-I-[1]-[2]-[3]-B-T1-[4]-[6]
		L	ICSA3 [ICSPA3] -BB3MB2L-I-[1]-[2]-[3]-B-T1-[4]-[6]
	4	H	ICSA3 [ICSPA3] -BB4MB2H-I-[1]-[2]-[3]-B-T1-[4]-[6]
		M	ICSA3 [ICSPA3] -BB4MB2M-I-[1]-[2]-[3]-B-T1-[4]-[6]
		L	ICSA3 [ICSPA3] -BB4MB2L-I-[1]-[2]-[3]-B-T1-[4]-[6]

\*1: Refer to the figure below for XY-axis configuration direction.

\*2: The load capacity and the maximum speed may vary depending on the type of Z-axis.

Note: T1 in the above models will be T2 when operated with XSEL-P/G type.

**Explanation of Model Code**

Number	Contents	Specification
①	X-axis stroke (Note 1)	20 : 200mm ~ 80 : 800mm
②	Y-axis stroke (Note 1)	10 : 100mm ~ 40 : 400mm
③	Z-axis stroke (Note 1)	10 : 100mm ~ 40 : 400mm
④	Cable length (Note 2)	3L : 3m 5L : 5m
⑤	Y-axis/ Z-axis cable management	SC-SC : Self-standing cable CT-CT : Cable track

\* The above explains the Models/Specifications chart to the left.

**Options**

Please add the option codes at the end of each stroke of the axis. When adding multiple options, put together in alphabetic order.

Name	Code	Page
AQ seal	AQ	→P13
Brake	B	→P13
Creep sensor	C	→P13
Home limit switch	L	→P14
Reversed-home specification	NM	→P14
Guide with ball-retaining mechanism	RT	→P14

**Configuration Direction**

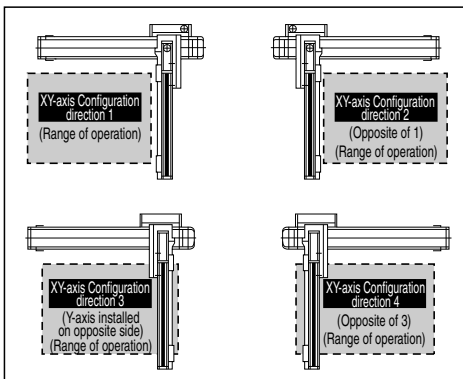

**Common Specifications**

\* [ ] is for the high-precision specification.

Drive system	Ball screw, rolled C10 [equivalent to rolled C5]
Positioning repeatability	±0.02mm [±0.01mm]
Backlash	0.05mm or less [0.02mm or less]
Guide	Integrated with base
Base	Material: Aluminum with white alumite treatment
X-axis motor output / lead	100W / 10mm
Y-axis motor output / lead	60W / 8mm
Z-axis motor output / lead	100W / 20mm (H), 10mm (M), 5mm (L)

**Applicable Controller Specifications**

Refer to page 65 for System Configuration.

**Axis Configuration**

\* [ ] is for the high-precision specification.

Axis Type	Model	Page
X-axis	ISA[ISPA]-MXM-[ ]-100-10-(Stroke)-T1	→P18
Y-axis	ISA[ISPA]-SYM-[ ]-60-8-(Stroke)-T1	→P16
Z-axis	ISA[ISPA]-MXM-[ ]-100-20/10/5-(Stroke)-T1-B	→P18

\*In the above model name, [ ] indicates encoder type A (absolute) or I (incremental).

**Caution**

(Note 1) The stroke in the model is specified in cm (centimeters).  
 (Note 2) The cable length measures from the X-axis connector box to the controller. The standard lengths are 3m and 5m, but other lengths can also be specified in meters. The maximum length is 20m.  
 (Note 3) The rated acceleration is 0.3G. Increasing the acceleration will result in lower load capacity.  
 (Note 4) Please note that a longer stroke will result in a lower maximum speed.

\* For other points to note, please refer to page 49.

ICSA3 [ICSPA3] -BB□MB2□

**Load Capacity (kg) (Note3)**

■BB□MB2H

		Y-axis stroke			
		100	200	300	400
Z-axis stroke	100	3.5			
	200	3.5			
	300	3.5			
	400	3.5			

■BB□MB2M

		Y-axis stroke			
		100	200	300	400
Z-axis stroke	100	9.0			
	200	9.0			
	300	9.0			
	400	9.0			

■BB□MB2L

		Y-axis stroke			
		100	200	300	400
Z-axis stroke	100	15.9			12.7
	200	14.6			11.4
	300	13.8			10.6
	400	12.8			9.6

**Maximum Speed by Stroke (mm/sec) (Note4)**

■BB□MB2H

	Stroke								
	100	200	300	400	500	600	700	800	
X-axis	500							480	380
Y-axis	400				-	-	-	-	-
Z-axis	1000	-	-	-	-	-	-	-	

■BB□MB2M

	Stroke								
	100	200	300	400	500	600	700	800	
X-axis	500							480	380
Y-axis	400				-	-	-	-	
Z-axis	500	-	-	-	-	-	-	-	

■BB□MB2L

	Stroke								
	100	200	300	400	500	600	700	800	
X-axis	500							480	380
Y-axis	400				-	-	-	-	
Z-axis	250	-	-	-	-	-	-	-	

**Dimensions**

\* The dimension below is for XY-axis Configuration direction 1.

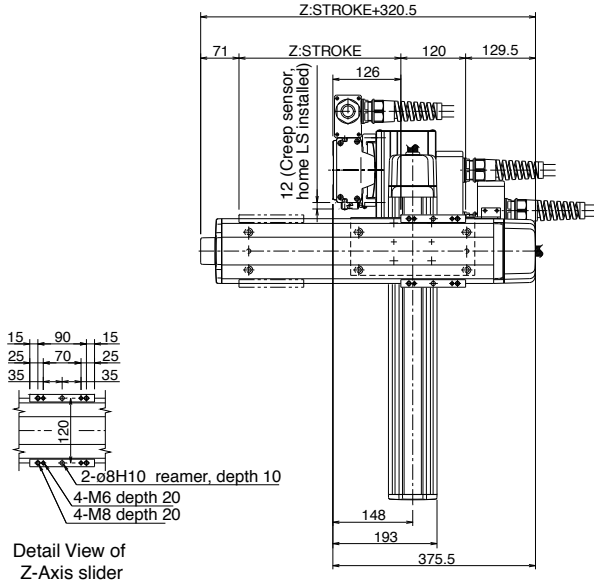

Detail View of Z-Axis slider

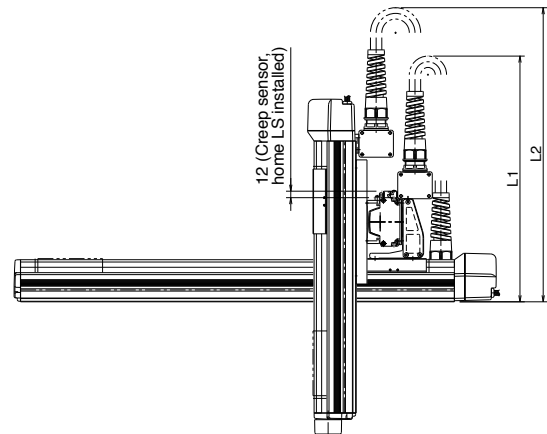
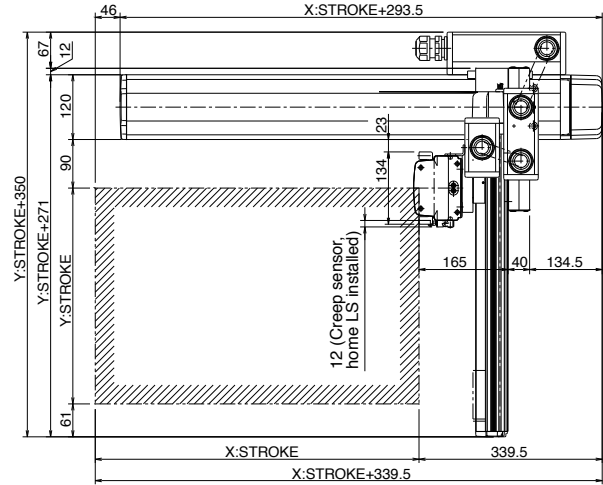

\* The configuration position in the figure is home position. To change the home position, indicate NM in the option. Note that changing the home direction will require the actuator to be returned to IAI for adjustment.

X stroke	200	300	400	500	600	700	800
L1	(550)	(600)	(650)	(700)	(750)	(800)	(850)
A	104	204	104	204	104	204	104
B	1	1	2	2	3	3	4
C	6	6	8	8	10	10	12

Y stroke	100	200	300	400
L2	(600)	(650)	(700)	(750)

**ICSA3-BC**  **HB1**  Cartesian Robot: X-Y-Z 3-Axes Configuration  
Z-Axis Base Mount Type

**ICSPA3-BC**  **HB1**  Cartesian Robot: X-Y-Z 3-Axes Configuration  
Z-Axis Base Mount Type High-Precision Specification

Type XYB + Z-Axis Base Mount Type Stroke X-axis: 200-800mm Y-axis: 100-500mm Z-axis: 100-400mm Load capacity 14kg ~ 3kg

Model specification items Series Type Encoder type X-axis stroke + options Y-axis stroke + options Z-axis stroke + options Applicable controller Cable length Cable management  
(Example) ICSA3 (ICSPA3) - BC-HB1M - A - 70AQL - 40AQL - 30BL - T1 - 5L - SC-SC

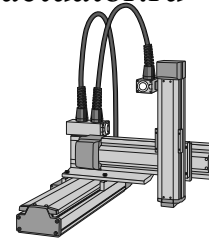

\* Refer to page 51 for the details of model specification items.

**Models/Specifications** \* [ ] is for the high-precision specification.

Encoder Type	XY-axis configuration direction (*1)	Z-axis type (*2)	Model
Absolute	1	H	ICSA3 [ICSPA3] -BC1HB1H-A- [1]-[2]-[3]-B-T1-[4]-[5]
		M	ICSA3 [ICSPA3] -BC1HB1M-A- [1]-[2]-[3]-B-T1-[4]-[5]
		L	ICSA3 [ICSPA3] -BC1HB1L-A- [1]-[2]-[3]-B-T1-[4]-[5]
	2	H	ICSA3 [ICSPA3] -BC2HB1H-A- [1]-[2]-[3]-B-T1-[4]-[5]
		M	ICSA3 [ICSPA3] -BC2HB1M-A- [1]-[2]-[3]-B-T1-[4]-[5]
		L	ICSA3 [ICSPA3] -BC2HB1L-A- [1]-[2]-[3]-B-T1-[4]-[5]
	3	H	ICSA3 [ICSPA3] -BC3HB1H-A- [1]-[2]-[3]-B-T1-[4]-[5]
		M	ICSA3 [ICSPA3] -BC3HB1M-A- [1]-[2]-[3]-B-T1-[4]-[5]
		L	ICSA3 [ICSPA3] -BC3HB1L-A- [1]-[2]-[3]-B-T1-[4]-[5]
	4	H	ICSA3 [ICSPA3] -BC4HB1H-A- [1]-[2]-[3]-B-T1-[4]-[5]
		M	ICSA3 [ICSPA3] -BC4HB1M-A- [1]-[2]-[3]-B-T1-[4]-[5]
		L	ICSA3 [ICSPA3] -BC4HB1L-A- [1]-[2]-[3]-B-T1-[4]-[5]
Incremental	1	H	ICSA3 [ICSPA3] -BC1HB1H-I- [1]-[2]-[3]-B-T1-[4]-[5]
		M	ICSA3 [ICSPA3] -BC1HB1M-I- [1]-[2]-[3]-B-T1-[4]-[5]
		L	ICSA3 [ICSPA3] -BC1HB1L-I- [1]-[2]-[3]-B-T1-[4]-[5]
	2	H	ICSA3 [ICSPA3] -BC2HB1H-I- [1]-[2]-[3]-B-T1-[4]-[5]
		M	ICSA3 [ICSPA3] -BC2HB1M-I- [1]-[2]-[3]-B-T1-[4]-[5]
		L	ICSA3 [ICSPA3] -BC2HB1L-I- [1]-[2]-[3]-B-T1-[4]-[5]
	3	H	ICSA3 [ICSPA3] -BC3HB1H-I- [1]-[2]-[3]-B-T1-[4]-[5]
		M	ICSA3 [ICSPA3] -BC3HB1M-I- [1]-[2]-[3]-B-T1-[4]-[5]
		L	ICSA3 [ICSPA3] -BC3HB1L-I- [1]-[2]-[3]-B-T1-[4]-[5]
	4	H	ICSA3 [ICSPA3] -BC4HB1H-I- [1]-[2]-[3]-B-T1-[4]-[5]
		M	ICSA3 [ICSPA3] -BC4HB1M-I- [1]-[2]-[3]-B-T1-[4]-[5]
		L	ICSA3 [ICSPA3] -BC4HB1L-I- [1]-[2]-[3]-B-T1-[4]-[5]

\*1: Refer to the figure below for XY-axis configuration direction.  
\*2: The load capacity and the maximum speed may vary depending on the type of Z-axis.  
Note: T1 in the above models will be T2 when operated with XSEL-P/Q type.

**Explanation of Model Code**

Number	Contents	Specification
①	X-axis stroke (Note 1)	20 : 200mm ~ 80 : 800mm
②	Y-axis stroke (Note 1)	10 : 100mm ~ 50 : 500mm
③	Z-axis stroke (Note 1)	10 : 100mm ~ 40 : 400mm
④	Cable length (Note 2)	3L : 3m 5L : 5m
⑤	Y-axis/ Z-axis cable management	SC-SC : Self-standing cable CT-CT : Cable track

\* The above explains the Models/Specifications chart to the left.

**Options**

Please add the option codes at the end of each stroke of the axis.  
When adding multiple options, put together in alphabetic order.

Name	Code	Page
AQ seal	AQ	→P13
Brake	B	→P13
Creep sensor	C	→P13
Home limit switch	L	→P14
Reversed-home specification	NM	→P14
Guide with ball-retaining mechanism	RT	→P14

**Configuration Direction**

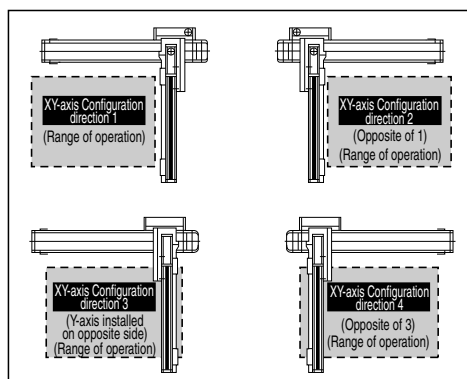

**Common Specifications** \* [ ] is for the high-precision specification.

Drive system	Ball screw, rolled C10 [equivalent to rolled C5]
Positioning repeatability	±0.02mm [±0.01mm]
Backlash	0.05mm or less [0.02mm or less]
Guide	Integrated with base
Base	Material: Aluminum with white alumite treatment
X-axis motor output / lead	200W / 20mm
Y-axis motor output / lead	100W / 20mm
Z-axis motor output / lead	60W / 16mm (H), 8mm (M), 4mm (L)

**Applicable Controller Specifications**

Refer to page 65 for System Configuration.

**Axis Configuration** \* [ ] is for the high-precision specification.

Axis Type	Model	Page
X-axis	ISA[ISPA]-MXM-□-200-20-(Stroke)-T1	→P19
Y-axis	ISA[ISPA]-MYM-□-100-20-(Stroke)-T1	→P21
Z-axis	ISA[ISPA]-SXM-□-60-16/8/4-(Stroke)-T1-B	→P15

\*In the above model name, □ indicates encoder type A (absolute) or I (incremental).

**Caution**

(Note 1) The stroke in the model is specified in cm (centimeters).  
(Note 2) The cable length measures from the X-axis connector box to the controller. The standard lengths are 3m and 5m, but other lengths can also be specified in meters. The maximum length is 20m.  
(Note 3) The rated acceleration is 0.3G. Increasing the acceleration will result in lower load capacity.  
(Note 4) Please note that a longer stroke will result in a lower maximum speed.

\* For other points to note, please refer to page 49.

ICSA3 [ICSPA3] - BC□HB1□

Single-Axis Robots

Cartesian Robots

Controllers

**Load Capacity (kg) (Note3)**

BC□HB1H

		Y-axis stroke				
		100	200	300	400	500
Z-axis stroke	100	3.0				
	200	3.0				
	300	3.0				
	400	3.0				

BC□HB1M

		Y-axis stroke				
		100	200	300	400	500
Z-axis stroke	100	6.0				
	200	6.0				
	300	6.0				
	400	6.0				

BC□HB1L

		Y-axis stroke				
		100	200	300	400	500
Z-axis stroke	100	14.0				13.5
	200	14.0				12.9
	300	14.0				12.3
	300	13.5				11.7

**Maximum Speed by Stroke (mm/sec) (Note4)**

BC□HB1H

	Stroke								
	100	200	300	400	500	600	700	800	
X-axis	-	1000						795	
Y-axis	1000				-	-	-	-	-
Z-axis	800		-	-	-	-	-	-	-

BC□HB1M

	Stroke								
	100	200	300	400	500	600	700	800	
X-axis	-	1000						795	
Y-axis	1000				-	-	-	-	-
Z-axis	400		-	-	-	-	-	-	-

BC□HB1L

	Stroke								
	100	200	300	400	500	600	700	800	
X-axis	-	1000						795	
Y-axis	1000				-	-	-	-	-
Z-axis	200		-	-	-	-	-	-	-

**Dimensions**

\* The dimension below is for XY-axis Configuration direction 1.

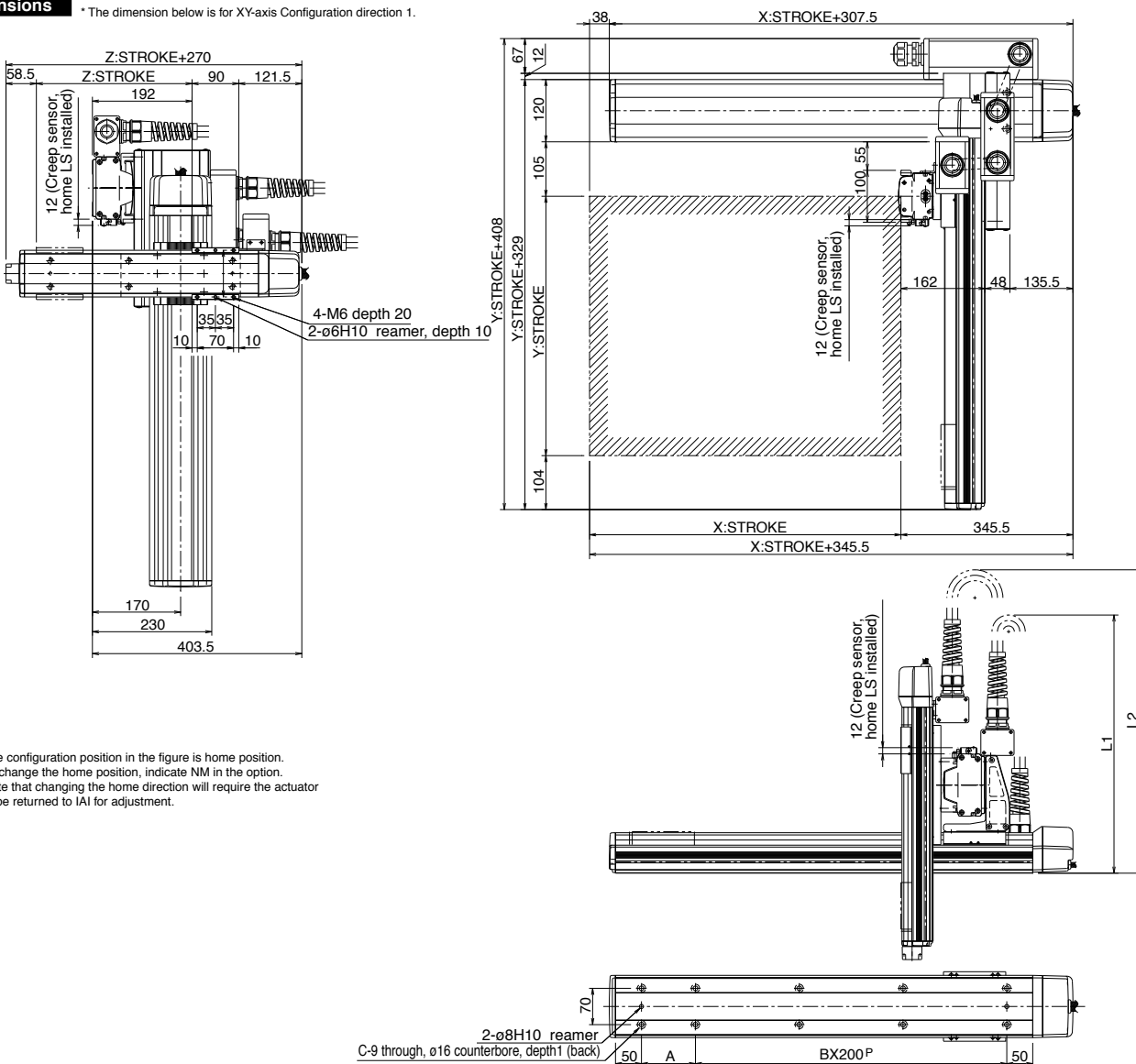

\* The configuration position in the figure is home position. To change the home position, indicate NM in the option. Note that changing the home direction will require the actuator to be returned to IAI for adjustment.

X stroke	200	300	400	500	600	700	800
L1	(550)	(600)	(650)	(700)	(750)	(800)	(850)
A	104	204	104	204	104	204	104
B	1	1	2	2	3	3	4
C	6	6	8	8	10	10	12

Y stroke	100	200	300	400	500
L2	(630)	(680)	(730)	(780)	(830)

<b>ICSA3-BC</b> <input type="checkbox"/> <b>HB2</b> <input type="checkbox"/>	Cartesian Robot: X-Y-Z 3-Axes Configuration Z-Axis Base Mount Type								
<b>ICSPA3-BC</b> <input type="checkbox"/> <b>HB2</b> <input type="checkbox"/>	Cartesian Robot: X-Y-Z 3-Axes Configuration Z-Axis Base Mount Type High-Precision Specification								
Type XYB + Z-Axis Base Mount Type	Stroke X-axis: 200-800mm Y-axis: 100-500mm Z-axis: 100-400mm	Load capacity 10.7kg ~ 3.5kg							
Model specification items	Series ICSPA3 (ICSPA3) - BC1HB2M -	Type A	Encoder type -	X-axis stroke + options 70AQL	Y-axis stroke + options 40AQL	Z-axis stroke + options 30BL	Applicable controller T1	Cable length 5L	Cable management SC - SC

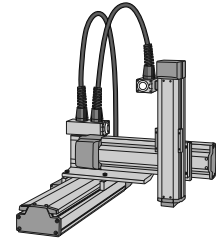

\* Refer to page 51 for the details of model specification items.

**Models/Specifications**

\* [ ] is for the high-precision specification.

Encoder Type	XY-axis configuration direction (*1)	Z-axis type (*2)	Model
Absolute	1	H	ICSA3 [ICSPA3] -BC1HB2H-A- [1] - [2] - [3] -B-T1- [4] - [5]
		M	ICSA3 [ICSPA3] -BC1HB2M-A- [1] - [2] - [3] -B-T1- [4] - [5]
		L	ICSA3 [ICSPA3] -BC1HB2L-A- [1] - [2] - [3] -B-T1- [4] - [5]
	2	H	ICSA3 [ICSPA3] -BC2HB2H-A- [1] - [2] - [3] -B-T1- [4] - [5]
		M	ICSA3 [ICSPA3] -BC2HB2M-A- [1] - [2] - [3] -B-T1- [4] - [5]
		L	ICSA3 [ICSPA3] -BC2HB2L-A- [1] - [2] - [3] -B-T1- [4] - [5]
	3	H	ICSA3 [ICSPA3] -BC3HB2H-A- [1] - [2] - [3] -B-T1- [4] - [5]
		M	ICSA3 [ICSPA3] -BC3HB2M-A- [1] - [2] - [3] -B-T1- [4] - [5]
		L	ICSA3 [ICSPA3] -BC3HB2L-A- [1] - [2] - [3] -B-T1- [4] - [5]
	4	H	ICSA3 [ICSPA3] -BC4HB2H-A- [1] - [2] - [3] -B-T1- [4] - [5]
		M	ICSA3 [ICSPA3] -BC4HB2M-A- [1] - [2] - [3] -B-T1- [4] - [5]
		L	ICSA3 [ICSPA3] -BC4HB2L-A- [1] - [2] - [3] -B-T1- [4] - [5]
Incremental	1	H	ICSA3 [ICSPA3] -BC1HB2H-I- [1] - [2] - [3] -B-T1- [4] - [5]
		M	ICSA3 [ICSPA3] -BC1HB2M-I- [1] - [2] - [3] -B-T1- [4] - [5]
		L	ICSA3 [ICSPA3] -BC1HB2L-I- [1] - [2] - [3] -B-T1- [4] - [5]
	2	H	ICSA3 [ICSPA3] -BC2HB2H-I- [1] - [2] - [3] -B-T1- [4] - [5]
		M	ICSA3 [ICSPA3] -BC2HB2M-I- [1] - [2] - [3] -B-T1- [4] - [5]
		L	ICSA3 [ICSPA3] -BC2HB2L-I- [1] - [2] - [3] -B-T1- [4] - [5]
	3	H	ICSA3 [ICSPA3] -BC3HB2H-I- [1] - [2] - [3] -B-T1- [4] - [5]
		M	ICSA3 [ICSPA3] -BC3HB2M-I- [1] - [2] - [3] -B-T1- [4] - [5]
		L	ICSA3 [ICSPA3] -BC3HB2L-I- [1] - [2] - [3] -B-T1- [4] - [5]
	4	H	ICSA3 [ICSPA3] -BC4HB2H-I- [1] - [2] - [3] -B-T1- [4] - [5]
		M	ICSA3 [ICSPA3] -BC4HB2M-I- [1] - [2] - [3] -B-T1- [4] - [5]
		L	ICSA3 [ICSPA3] -BC4HB2L-I- [1] - [2] - [3] -B-T1- [4] - [5]

\*1: Refer to the figure below for XY-axis configuration direction.  
\*2: The load capacity and the maximum speed may vary depending on the type of Z-axis.  
Note: T1 in the above models will be T2 when operated with XSEL-P/G type.

**Explanation of Model Code**

Number	Contents	Specification
[1]	X-axis stroke (Note 1)	20 : 200mm ~ 80 : 800mm
[2]	Y-axis stroke (Note 1)	10 : 100mm ~ 50 : 500mm
[3]	Z-axis stroke (Note 1)	10 : 100mm ~ 40 : 400mm
[4]	Cable length (Note 2)	3L : 3m 5L : 5m
[5]	Y-axis/ Z-axis cable management	SC-SC : Self-standing cable CT-CT : Cable track

\* The above explains the Models/Specifications chart to the left.

**Options**

Please add the option codes at the end of each stroke of the axis.  
When adding multiple options, put together in alphabetic order.

Name	Code	Page
AQ seal	AQ	→P13
Brake	B	→P13
Creep sensor	C	→P13
Home limit switch	L	→P14
Reversed-home specification	NM	→P14
Guide with ball-retaining mechanism	RT	→P14

**Configuration Direction**

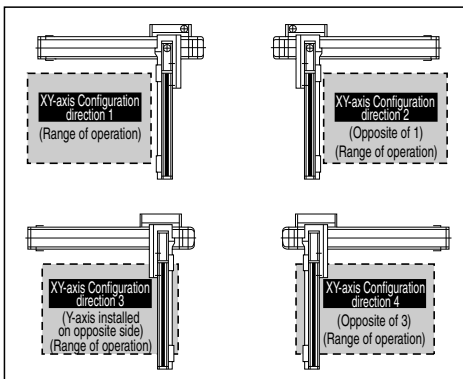

**Common Specifications**

\* [ ] is for the high-precision specification.

Drive system	Ball screw, rolled C10 [equivalent to rolled C5]
Positioning repeatability	±0.02mm [±0.01mm]
Backlash	0.05mm or less [0.02mm or less]
Guide	Integrated with base
Base	Material: Aluminum with white alumite treatment
X-axis motor output / lead	200W / 20mm
Y-axis motor output / lead	100W / 20mm
Z-axis motor output / lead	100W / 20mm (H), 10mm (M), 5mm (L)

**Applicable Controller Specifications**

Refer to page 65 for System Configuration.

**Axis Configuration**

\* [ ] is for the high-precision specification.

Axis Type	Model	Page
X-axis	ISA[ISPA]-MXM-□-200-20-(Stroke)-T1	→P19
Y-axis	ISA[ISPA]-MYM-□-100-20-(Stroke)-T1	→P21
Z-axis	ISA[ISPA]-MXM-□-100-20/10/5-(Stroke)-T1-B	→P18

\*In the above model name, □ indicates encoder type A (absolute) or I (incremental).

**Caution**

(Note 1) The stroke in the model is specified in cm (centimeters).  
 (Note 2) The cable length measures from the X-axis connector box to the controller. The standard lengths are 3m and 5m, but other lengths can also be specified in meters. The maximum length is 20m.  
 (Note 3) The rated acceleration is 0.3G. Increasing the acceleration will result in lower load capacity.  
 (Note 4) Please note that a longer stroke will result in a lower maximum speed.

\* For other points to note, please refer to page 49.

ICSA3 [ICSPA3] - BC□HB2□

Single-Axis Robots

Cartesian Robots

Controllers

**Load Capacity (kg) (Note3)**

■ BC□HB2H

		Y-axis stroke				
		100	200	300	400	500
Z-axis stroke	100	3.5				
	200	3.5				
	300	3.5				
	400	3.5				

■ BC□HB2M

		Y-axis stroke				
		100	200	300	400	500
Z-axis stroke	100	9.0				
	200	9.0			8.4	
	300	8.6			7.3	
	400	7.6			6.3	

■ BC□HB2L

		Y-axis stroke				
		100	200	300	400	500
Z-axis stroke	100	10.7			9.4	
	200	9.7			8.4	
	300	8.6			7.3	
	300	7.6			6.3	

**Maximum Speed by Stroke (mm/sec) (Note4)**

■ BC□HB2H

	Stroke								
	100	200	300	400	500	600	700	800	
X-axis	-	1000						795	
Y-axis	1000				-	-	-	-	-
Z-axis	1000		-	-	-	-	-	-	

■ BC□HB2M

	Stroke								
	100	200	300	400	500	600	700	800	
X-axis	-	1000						795	
Y-axis	1000				-	-	-	-	
Z-axis	500		-	-	-	-	-	-	

■ BC□HB2L

	Stroke								
	100	200	300	400	500	600	700	800	
X-axis	-	1000						795	
Y-axis	1000				-	-	-	-	
Z-axis	250		-	-	-	-	-	-	

**Dimensions** \* The dimension below is for XY-axis Configuration direction 1.

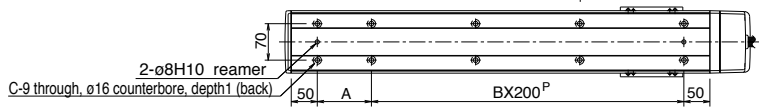
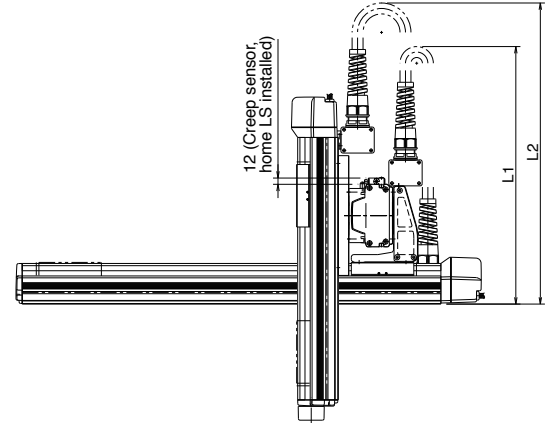
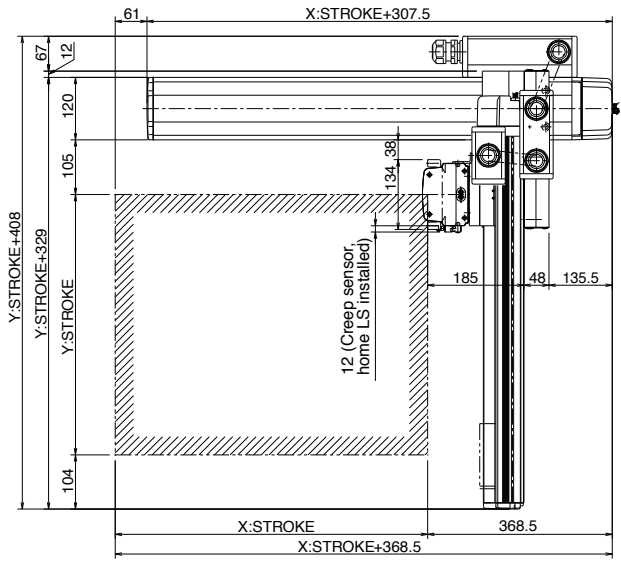
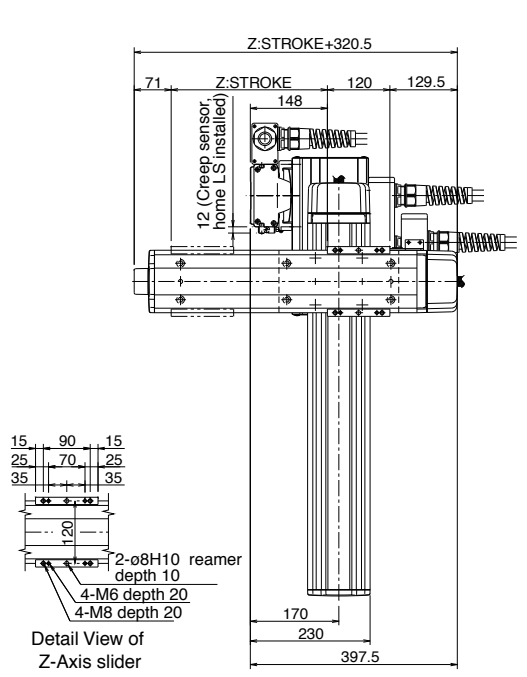

\* The configuration position in the figure is home position. To change the home position, indicate NM in the option. Note that changing the home direction will require the actuator to be returned to IAI for adjustment.

X stroke	200	300	400	500	600	700	800
L1	(550)	(600)	(650)	(700)	(750)	(800)	(850)
A	104	204	104	204	104	204	104
B	1	1	2	2	3	3	4
C	6	6	8	8	10	10	12

Y stroke	100	200	300	400	500
L2	(630)	(680)	(730)	(780)	(830)

<b>ICSA3-BC HB3</b>		Cartesian Robot: X-Y-Z 3-Axes Configuration Z-Axis Base Mount Type	
<b>ICSPA3-BC HB3</b>		Cartesian Robot: X-Y-Z 3-Axes Configuration Z-Axis Base Mount Type High-Precision Specification	
Type	XYB + Z-Axis Base Mount Type	Stroke	X-axis: 200-800mm Y-axis: 100-500mm Z-axis: 100-400mm
		Load capacity	10.7kg - 6.3kg
Model specification items	Series	Type	Encoder type
(Example)	ICSA3 (ICSPA3)	-BC1HB3M-	A
			- 70AQL - 40AQL - 30BL - T1 - 5L - SC - SC

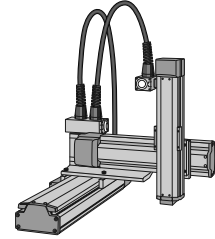

\* Refer to page 51 for the details of model specification items.

**Models/Specifications**

\* [ ] is for the high-precision specification.

Encoder Type	XY-axis configuration direction (*1)	Z-axis type (*2)	Model
Absolute	1	H	ICSA3 [ICSPA3] -BC1HB3H-A-[1]-[2]-[3]-B-T1-[4]-[6]
		M	ICSA3 [ICSPA3] -BC1HB3M-A-[1]-[2]-[3]-B-T1-[4]-[6]
	2	H	ICSA3 [ICSPA3] -BC2HB3H-A-[1]-[2]-[3]-B-T1-[4]-[6]
		M	ICSA3 [ICSPA3] -BC2HB3M-A-[1]-[2]-[3]-B-T1-[4]-[6]
	3	H	ICSA3 [ICSPA3] -BC3HB3H-A-[1]-[2]-[3]-B-T1-[4]-[6]
		M	ICSA3 [ICSPA3] -BC3HB3M-A-[1]-[2]-[3]-B-T1-[4]-[6]
4	H	ICSA3 [ICSPA3] -BC4HB3H-A-[1]-[2]-[3]-B-T1-[4]-[6]	
	M	ICSA3 [ICSPA3] -BC4HB3M-A-[1]-[2]-[3]-B-T1-[4]-[6]	
Incremental	1	H	ICSA3 [ICSPA3] -BC1HB3H-I-[1]-[2]-[3]-B-T1-[4]-[6]
		M	ICSA3 [ICSPA3] -BC1HB3M-I-[1]-[2]-[3]-B-T1-[4]-[6]
	2	H	ICSA3 [ICSPA3] -BC2HB3H-I-[1]-[2]-[3]-B-T1-[4]-[6]
		M	ICSA3 [ICSPA3] -BC2HB3M-I-[1]-[2]-[3]-B-T1-[4]-[6]
	3	H	ICSA3 [ICSPA3] -BC3HB3H-I-[1]-[2]-[3]-B-T1-[4]-[6]
		M	ICSA3 [ICSPA3] -BC3HB3M-I-[1]-[2]-[3]-B-T1-[4]-[6]
	4	H	ICSA3 [ICSPA3] -BC4HB3H-I-[1]-[2]-[3]-B-T1-[4]-[6]
		M	ICSA3 [ICSPA3] -BC4HB3M-I-[1]-[2]-[3]-B-T1-[4]-[6]

\*1: Refer to the figure below for XY-axis configuration direction.  
\*2: The load capacity and the maximum speed may vary depending on the type of Z-axis.  
Note: T1 in the above models will be T2 when operated with XSEL-P/Q type.

**Explanation of Model Code**

Number	Contents	Specification
①	X-axis stroke (Note 1)	20 : 200mm ~ 80 : 800mm
②	Y-axis stroke (Note 1)	10 : 100mm ~ 50 : 500mm
③	Z-axis stroke (Note 1)	10 : 100mm ~ 40 : 400mm
④	Cable length (Note 2)	3L : 3m 5L : 5m
⑤	Y-axis/ Z-axis cable management	SC-SC : Self-standing cable CT-CT : Cable track

\* The above explains the Models/Specifications chart to the left.

**Options**

Please add the option codes at the end of each stroke of the axis.  
When adding multiple options, put together in alphabetic order.

Name	Code	Page
AQ seal	AQ	→P13
Brake	B	→P13
Creep sensor	C	→P13
Home limit switch	L	→P14
Reversed-home specification	NM	→P14
Guide with ball-retaining mechanism	RT	→P14

**Configuration Direction**

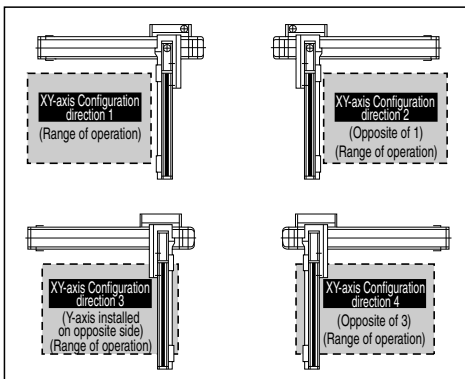

**Common Specifications**

\* [ ] is for the high-precision specification.

Drive system	Ball screw, rolled C10 [equivalent to rolled C5]
Positioning repeatability	±0.02mm [±0.01mm]
Backlash	0.05mm or less [0.02mm or less]
Guide	Integrated with base
Base	Material: Aluminum with white alumite treatment
X-axis motor output / lead	200W / 20mm
Y-axis motor output / lead	100W / 20mm
Z-axis motor output / lead	200W / 20mm (H), 10mm (M)

**Applicable Controller Specifications**

Refer to page 65 for System Configuration.

**Axis Configuration**

\* [ ] is for the high-precision specification.

Axis Type	Model	Page
X-axis	ISA[ISPA]-MXM-[ ]-200-20-(Stroke)-T1	→P19
Y-axis	ISA[ISPA]-MYM-[ ]-100-20-(Stroke)-T1	→P21
Z-axis	ISA[ISPA]-MXM-[ ]-200-20/10-(Stroke)-T1-B	→P19

\*In the above model name, [ ] indicates encoder type A (absolute) or I (incremental).

**Caution**

(Note 1) The stroke in the model is specified in cm (centimeters).  
 (Note 2) The cable length measures from the X-axis connector box to the controller. The standard lengths are 3m and 5m, but other lengths can also be specified in meters. The maximum length is 20m.  
 (Note 3) The rated acceleration is 0.3G. Increasing the acceleration will result in lower load capacity.  
 (Note 4) Please note that a longer stroke will result in a lower maximum speed.

\* For other points to note, please refer to page 49.



ICSA3 [ICSPA3] -BC□HB3□

**Load Capacity (kg) (Note3)**

**BC□HB3H**

		Y-axis stroke				
		100	200	300	400	500
Z-axis stroke	100	9.0				
	200	9.0			8.4	
	300	8.6			7.3	
	400	7.6			6.3	

**BC□HB3M**

		Y-axis stroke				
		100	200	300	400	500
Z-axis stroke	100	10.7			9.4	
	200	9.7			8.4	
	300	8.6			7.3	
	400	7.6			6.3	

**Maximum Speed by Stroke (mm/sec) (Note4)**

**BC□HB3H**

	Stroke								
	100	200	300	400	500	600	700	800	
X-axis	-	1000						795	
Y-axis	1000				-	-	-	-	-
Z-axis	1000		-	-	-	-	-	-	-

**BC□HB3M**

	Stroke								
	100	200	300	400	500	600	700	800	
X-axis	-	1000						795	
Y-axis	1000				-	-	-	-	-
Z-axis	500		-	-	-	-	-	-	-

**Dimensions**

\* The dimension below is for XY-axis Configuration direction 1.

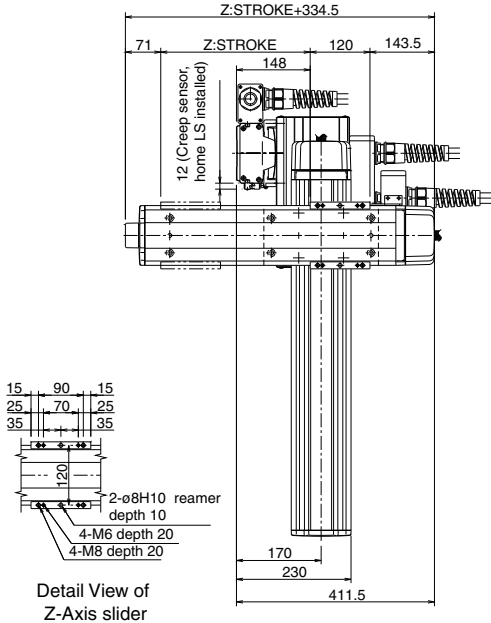

Detail View of Z-Axis slider

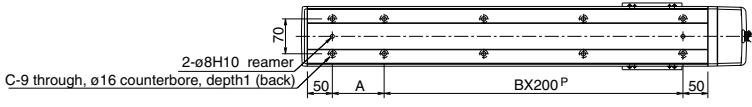
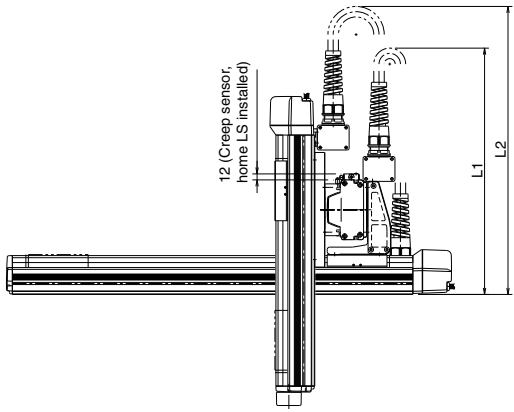
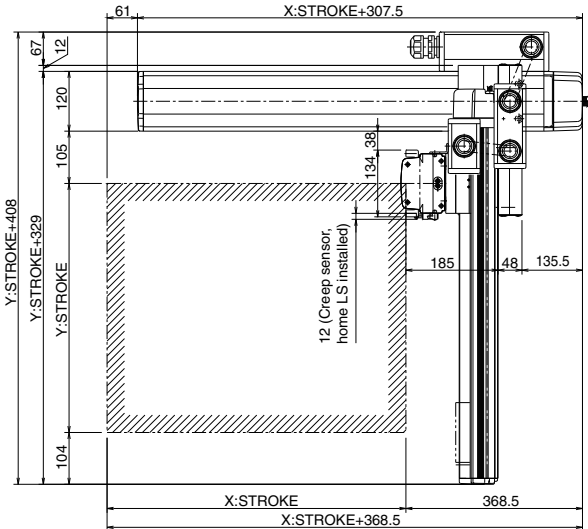

\* The configuration position in the figure is home position. To change the home position, indicate NM in the option. Note that changing the home direction will require the actuator to be returned to IAI for adjustment.

X stroke	200	300	400	500	600	700	800
L1	(550)	(600)	(650)	(700)	(750)	(800)	(850)
A	104	204	104	204	104	204	104
B	1	1	2	2	3	3	4
C	6	6	8	8	10	10	12

Y stroke	100	200	300	400	500
L2	(630)	(680)	(730)	(780)	(830)

<b>ICSA3-BC MB1</b>		Cartesian Robot: X-Y-Z 3-Axes Configuration Z-Axis Base Mount Type	
<b>ICSPA3-BC MB1</b>		Cartesian Robot: X-Y-Z 3-Axes Configuration Z-Axis Base Mount Type High-Precision Specification	
Type	XYB + Z-Axis Base Mount Type	Stroke	X-axis: 200-800mm Y-axis: 100-500mm Z-axis: 100-400mm
Load capacity	14kg ~ 3kg		
Model specification items	Series	Type	Encoder type
(Example)	ICSA3 (ICSPA3)	-BC1MB1M-	A
			- 70AQL - 40AQL - 30BL - T1 - 5L - SC - SC

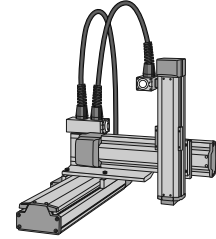

\* Refer to page 51 for the details of model specification items.

**Models/Specifications**

\* [ ] is for the high-precision specification.

Encoder Type	XY-axis configuration direction (*1)	Z-axis type (*2)	Model
Absolute	1	H	ICSA3 [ICSPA3] -BC1MB1H-A-[1]-[2]-[3]-B-T1-[4]-[5]
		M	ICSA3 [ICSPA3] -BC1MB1M-A-[1]-[2]-[3]-B-T1-[4]-[5]
		L	ICSA3 [ICSPA3] -BC1MB1L-A-[1]-[2]-[3]-B-T1-[4]-[5]
	2	H	ICSA3 [ICSPA3] -BC2MB1H-A-[1]-[2]-[3]-B-T1-[4]-[5]
		M	ICSA3 [ICSPA3] -BC2MB1M-A-[1]-[2]-[3]-B-T1-[4]-[5]
		L	ICSA3 [ICSPA3] -BC2MB1L-A-[1]-[2]-[3]-B-T1-[4]-[5]
	3	H	ICSA3 [ICSPA3] -BC3MB1H-A-[1]-[2]-[3]-B-T1-[4]-[5]
		M	ICSA3 [ICSPA3] -BC3MB1M-A-[1]-[2]-[3]-B-T1-[4]-[5]
		L	ICSA3 [ICSPA3] -BC3MB1L-A-[1]-[2]-[3]-B-T1-[4]-[5]
	4	H	ICSA3 [ICSPA3] -BC4MB1H-A-[1]-[2]-[3]-B-T1-[4]-[5]
		M	ICSA3 [ICSPA3] -BC4MB1M-A-[1]-[2]-[3]-B-T1-[4]-[5]
		L	ICSA3 [ICSPA3] -BC4MB1L-A-[1]-[2]-[3]-B-T1-[4]-[5]
Incremental	1	H	ICSA3 [ICSPA3] -BC1MB1H-I-[1]-[2]-[3]-B-T1-[4]-[5]
		M	ICSA3 [ICSPA3] -BC1MB1M-I-[1]-[2]-[3]-B-T1-[4]-[5]
		L	ICSA3 [ICSPA3] -BC1MB1L-I-[1]-[2]-[3]-B-T1-[4]-[5]
	2	H	ICSA3 [ICSPA3] -BC2MB1H-I-[1]-[2]-[3]-B-T1-[4]-[5]
		M	ICSA3 [ICSPA3] -BC2MB1M-I-[1]-[2]-[3]-B-T1-[4]-[5]
		L	ICSA3 [ICSPA3] -BC2MB1L-I-[1]-[2]-[3]-B-T1-[4]-[5]
	3	H	ICSA3 [ICSPA3] -BC3MB1H-I-[1]-[2]-[3]-B-T1-[4]-[5]
		M	ICSA3 [ICSPA3] -BC3MB1M-I-[1]-[2]-[3]-B-T1-[4]-[5]
		L	ICSA3 [ICSPA3] -BC3MB1L-I-[1]-[2]-[3]-B-T1-[4]-[5]
	4	H	ICSA3 [ICSPA3] -BC4MB1H-I-[1]-[2]-[3]-B-T1-[4]-[5]
		M	ICSA3 [ICSPA3] -BC4MB1M-I-[1]-[2]-[3]-B-T1-[4]-[5]
		L	ICSA3 [ICSPA3] -BC4MB1L-I-[1]-[2]-[3]-B-T1-[4]-[5]

\*1: Refer to the figure below for XY-axis configuration direction.  
\*2: The load capacity and the maximum speed may vary depending on the type of Z-axis.  
Note: T1 in the above models will be T2 when operated with XSEL-P/G type.

**Explanation of Model Code**

Number	Contents	Specification
①	X-axis stroke (Note 1)	20 : 200mm ~ 80 : 800mm
②	Y-axis stroke (Note 1)	10 : 100mm ~ 50 : 500mm
③	Z-axis stroke (Note 1)	10 : 100mm ~ 40 : 400mm
④	Cable length (Note 2)	3L : 3m 5L : 5m
⑤	Y-axis/ Z-axis cable management	SC-SC : Self-standing cable CT-CT : Cable track

\* The above explains the Models/Specifications chart to the left.

**Options**

Please add the option codes at the end of each stroke of the axis.  
When adding multiple options, put together in alphabetic order.

Name	Code	Page
AQ seal	AQ	→P13
Brake	B	→P13
Creep sensor	C	→P13
Home limit switch	L	→P14
Reversed-home specification	NM	→P14
Guide with ball-retaining mechanism	RT	→P14

**Configuration Direction**

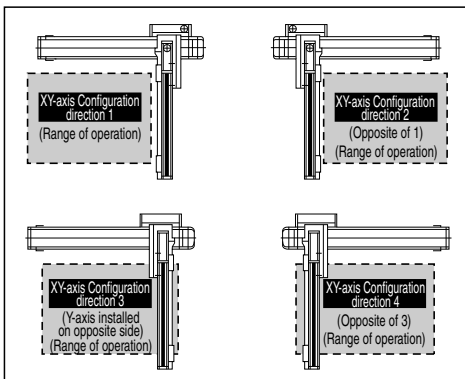

**Common Specifications**

\* [ ] is for the high-precision specification.

Drive system	Ball screw, rolled C10 [equivalent to rolled C5]
Positioning repeatability	±0.02mm [±0.01mm]
Backlash	0.05mm or less [0.02mm or less]
Guide	Integrated with base
Base	Material: Aluminum with white alumite treatment
X-axis motor output / lead	100W / 10mm
Y-axis motor output / lead	100W / 10mm
Z-axis motor output / lead	60W / 16mm (H), 8mm (M), 4mm (L)

**Applicable Controller Specifications**

Refer to page 65 for System Configuration.

**Axis Configuration**

\* [ ] is for the high-precision specification.

Axis Type	Model	Page
X-axis	ISA[ISPA]-MXM-[ ]-100-10-(Stroke)-T1	→P18
Y-axis	ISA[ISPA]-MYM-[ ]-100-10-(Stroke)-T1	→P21
Z-axis	ISA[ISPA]-SXM-[ ]-60-16/8/4-(Stroke)-T1-B	→P15

\*In the above model name, [ ] indicates encoder type A (absolute) or I (incremental).

**Caution**

(Note 1) The stroke in the model is specified in cm (centimeters).  
 (Note 2) The cable length measures from the X-axis connector box to the controller. The standard lengths are 3m and 5m, but other lengths can also be specified in meters. The maximum length is 20m.  
 (Note 3) The rated acceleration is 0.3G. Increasing the acceleration will result in lower load capacity.  
 (Note 4) Please note that a longer stroke will result in a lower maximum speed.

\* For other points to note, please refer to page 49.

ICSA3 [ICSPA3] - BC□MB1□

Load Capacity (kg) (Note3)

BC□MB1H

		Y-axis stroke				
		100	200	300	400	500
Z-axis stroke	100	3.0				
	200	3.0				
	300	3.0				
	400	3.0				

BC□MB1M

		Y-axis stroke				
		100	200	300	400	500
Z-axis stroke	100	6.0				
	200	6.0				
	300	6.0				
	400	6.0				

BC□MB1L

		Y-axis stroke				
		100	200	300	400	500
Z-axis stroke	100	14.0				13.5
	200	14.0				12.9
	300	14.0				12.3
	300	13.5				11.7

Maximum Speed by Stroke (mm/sec) (Note4)

BC□MB1H

	Stroke								
	100	200	300	400	500	600	700	800	
X-axis	-	500					480	380	
Y-axis	500					-	-	-	
Z-axis	800		-	-	-	-	-		

BC□MB1M

	Stroke								
	100	200	300	400	500	600	700	800	
X-axis	-	500					480	380	
Y-axis	500					-	-	-	
Z-axis	400		-	-	-	-	-		

BC□MB1L

	Stroke								
	100	200	300	400	500	600	700	800	
X-axis	-	500					480	380	
Y-axis	500					-	-	-	
Z-axis	200		-	-	-	-	-		

Dimensions

\* The dimension below is for XY-axis Configuration direction 1.

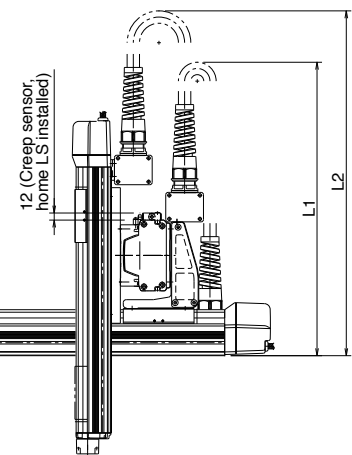
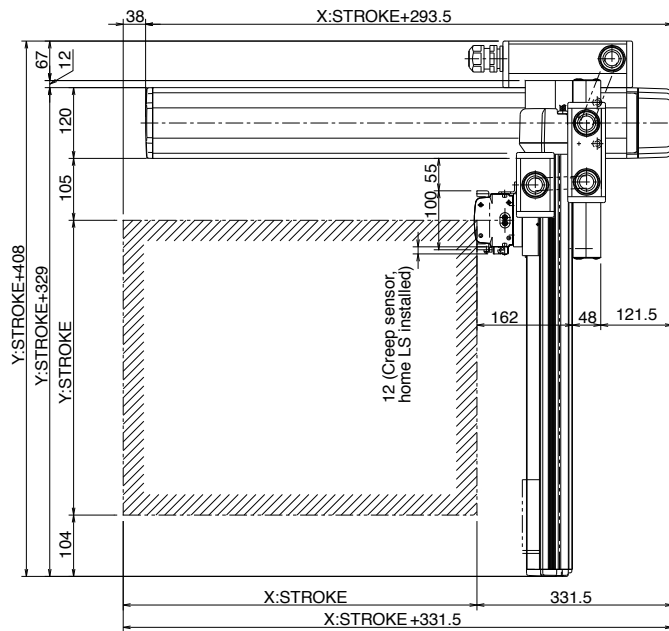
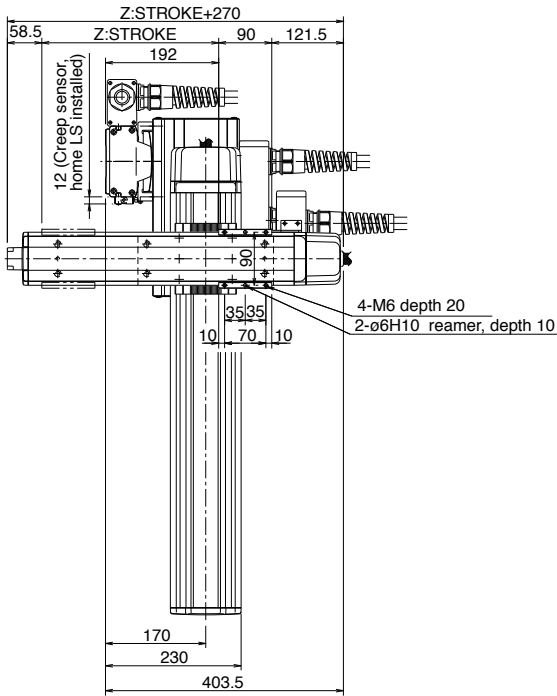

\* The configuration position in the figure is home position. To change the home position, indicate NM in the option. Note that changing the home direction will require the actuator to be returned to IAI for adjustment.

2-ø8H10 reamer  
C-9 through, ø16 counterbore, depth 1 (back)

X stroke	200	300	400	500	600	700	800
L1	(550)	(600)	(650)	(700)	(750)	(800)	(850)
A	104	204	104	204	104	204	104
B	1	1	2	2	3	3	4
C	6	6	8	8	10	10	12

Y stroke	100	200	300	400	500
L2	(630)	(680)	(730)	(780)	(830)

<b>ICSA3-BC MB2</b>		Cartesian Robot: X-Y-Z 3-Axes Configuration Z-Axis Base Mount Type	
<b>ICSPA3-BC MB2</b>		Cartesian Robot: X-Y-Z 3-Axes Configuration Z-Axis Base Mount Type High-Precision Specification	
Type	XYB + Z-Axis Base Mount Type	Stroke	X-axis: 200-800mm Y-axis: 100-500mm Z-axis: 100-400mm
		Load capacity	19kg ~ 3.5kg
Model specification items	Series	Type	Encoder type
(Example)	ICSA3 (ICSPA3)	BC1MB2M	A
			X-axis stroke + options
			Y-axis stroke + options
			Z-axis stroke + options
			Applicable controller
			Cable length
			Cable management
			70AQL - 40AQL - 30BL - T1 - 5L - SC - SC

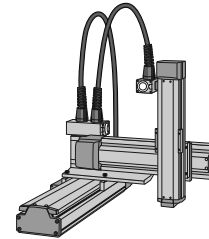

\* Refer to page 51 for the details of model specification items.

**Models/Specifications**

\* [ ] is for the high-precision specification.

Encoder Type	XY-axis configuration direction (*1)	Z-axis type (*2)	Model
Absolute	1	H	ICSA3 [ICSPA3] -BC1MB2H-A-[1]-[2]-[3]-B-T1-[4]-[5]
		M	ICSA3 [ICSPA3] -BC1MB2M-A-[1]-[2]-[3]-B-T1-[4]-[5]
		L	ICSA3 [ICSPA3] -BC1MB2L-A-[1]-[2]-[3]-B-T1-[4]-[5]
	2	H	ICSA3 [ICSPA3] -BC2MB2H-A-[1]-[2]-[3]-B-T1-[4]-[5]
		M	ICSA3 [ICSPA3] -BC2MB2M-A-[1]-[2]-[3]-B-T1-[4]-[5]
		L	ICSA3 [ICSPA3] -BC2MB2L-A-[1]-[2]-[3]-B-T1-[4]-[5]
	3	H	ICSA3 [ICSPA3] -BC3MB2H-A-[1]-[2]-[3]-B-T1-[4]-[5]
		M	ICSA3 [ICSPA3] -BC3MB2M-A-[1]-[2]-[3]-B-T1-[4]-[5]
		L	ICSA3 [ICSPA3] -BC3MB2L-A-[1]-[2]-[3]-B-T1-[4]-[5]
	4	H	ICSA3 [ICSPA3] -BC4MB2H-A-[1]-[2]-[3]-B-T1-[4]-[5]
		M	ICSA3 [ICSPA3] -BC4MB2M-A-[1]-[2]-[3]-B-T1-[4]-[5]
		L	ICSA3 [ICSPA3] -BC4MB2L-A-[1]-[2]-[3]-B-T1-[4]-[5]
Incremental	1	H	ICSA3 [ICSPA3] -BC1MB2H-I-[1]-[2]-[3]-B-T1-[4]-[5]
		M	ICSA3 [ICSPA3] -BC1MB2M-I-[1]-[2]-[3]-B-T1-[4]-[5]
		L	ICSA3 [ICSPA3] -BC1MB2L-I-[1]-[2]-[3]-B-T1-[4]-[5]
	2	H	ICSA3 [ICSPA3] -BC2MB2H-I-[1]-[2]-[3]-B-T1-[4]-[5]
		M	ICSA3 [ICSPA3] -BC2MB2M-I-[1]-[2]-[3]-B-T1-[4]-[5]
		L	ICSA3 [ICSPA3] -BC2MB2L-I-[1]-[2]-[3]-B-T1-[4]-[5]
	3	H	ICSA3 [ICSPA3] -BC3MB2H-I-[1]-[2]-[3]-B-T1-[4]-[5]
		M	ICSA3 [ICSPA3] -BC3MB2M-I-[1]-[2]-[3]-B-T1-[4]-[5]
		L	ICSA3 [ICSPA3] -BC3MB2L-I-[1]-[2]-[3]-B-T1-[4]-[5]
	4	H	ICSA3 [ICSPA3] -BC4MB2H-I-[1]-[2]-[3]-B-T1-[4]-[5]
		M	ICSA3 [ICSPA3] -BC4MB2M-I-[1]-[2]-[3]-B-T1-[4]-[5]
		L	ICSA3 [ICSPA3] -BC4MB2L-I-[1]-[2]-[3]-B-T1-[4]-[5]

\*1: Refer to the figure below for XY-axis configuration direction.  
\*2: The load capacity and the maximum speed may vary depending on the type of Z-axis.  
Note: T1 in the above models will be T2 when operated with XSEL-P/Q type.

**Explanation of Model Code**

Number	Contents	Specification
①	X-axis stroke (Note 1)	20 : 200mm ~ 80 : 800mm
②	Y-axis stroke (Note 1)	10 : 100mm ~ 50 : 500mm
③	Z-axis stroke (Note 1)	10 : 100mm ~ 40 : 400mm
④	Cable length (Note 2)	3L : 3m 5L : 5m
⑤	Y-axis/ Z-axis cable management	SC-SC : Self-standing cable CT-CT : Cable track

\* The above explains the Models/Specifications chart to the left.

**Options**

Please add the option codes at the end of each stroke of the axis.  
When adding multiple options, put together in alphabetic order.

Name	Code	Page
AQ seal	AQ	→P13
Brake	B	→P13
Creep sensor	C	→P13
Home limit switch	L	→P14
Reversed-home specification	NM	→P14
Guide with ball-retaining mechanism	RT	→P14

**Configuration Direction**

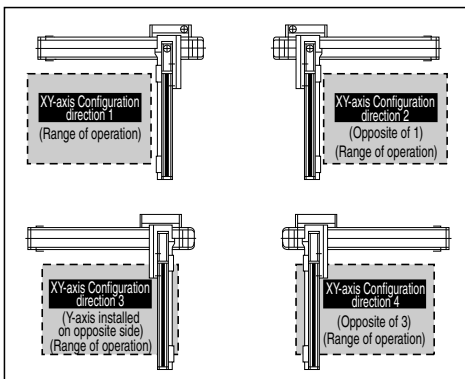

**Common Specifications**

\* [ ] is for the high-precision specification.

Drive system	Ball screw, rolled C10 [equivalent to rolled C5]
Positioning repeatability	±0.02mm [±0.01mm]
Backlash	0.05mm or less [0.02mm or less]
Guide	Integrated with base
Base	Material: Aluminum with white alumite treatment
X-axis motor output / lead	100W / 10mm
Y-axis motor output / lead	100W / 10mm
Z-axis motor output / lead	100W / 20mm (H), 10mm (M), 5mm (L)

**Applicable Controller Specifications**

Refer to page 65 for System Configuration.

**Axis Configuration**

\* [ ] is for the high-precision specification.

Axis Type	Model	Page
X-axis	ISA[ISPA]-MXM-[ ]-100-10-(Stroke)-T1	→P18
Y-axis	ISA[ISPA]-MYM-[ ]-100-10-(Stroke)-T1	→P21
Z-axis	ISA[ISPA]-MXM-[ ]-100-20/10/5-(Stroke)-T1-B	→P18

\*In the above model name, [ ] indicates encoder type A (absolute) or I (incremental).

**Caution**

(Note 1) The stroke in the model is specified in cm (centimeters).  
 (Note 2) The cable length measures from the X-axis connector box to the controller. The standard lengths are 3m and 5m, but other lengths can also be specified in meters. The maximum length is 20m.  
 (Note 3) The rated acceleration is 0.3G. Increasing the acceleration will result in lower load capacity.  
 (Note 4) Please note that a longer stroke will result in a lower maximum speed.

\* For other points to note, please refer to page 49.

ICSA3 [ICSPA3] - BC□MB2□

Single-Axis Robots

Cartesian Robots

Controllers

Load Capacity (kg) (Note3)

BC□MB2H

		Y-axis stroke				
		100	200	300	400	500
Z-axis stroke	100	3.5				
	200	3.5				
	300	3.5				
	400	3.5				

BC□MB2M

		Y-axis stroke				
		100	200	300	400	500
Z-axis stroke	100	9.0				
	200	9.0			8.4	
	300	9.0			7.3	
	400	9.0			6.3	

BC□MB2L

		Y-axis stroke				
		100	200	300	400	500
Z-axis stroke	100	19.0	18.5	17.5	12.5	9.4
	200	18.5	17.5	16.5	11.5	8.4
	300	17.4	16.4	15.4	10.4	7.3
	300	16.4	15.4	14.4	9.4	6.3

Maximum Speed by Stroke (mm/sec) (Note4)

BC□MB2H

	Stroke								
	100	200	300	400	500	600	700	800	
X-axis	-	500				480			380
Y-axis	500				-	-	-	-	-
Z-axis	1000		-	-	-	-	-	-	

BC□MB2M

	Stroke								
	100	200	300	400	500	600	700	800	
X-axis	-	500				480			380
Y-axis	500				-	-	-	-	
Z-axis	500		-	-	-	-	-	-	

BC□MB2L

	Stroke								
	100	200	300	400	500	600	700	800	
X-axis	-	500				480			380
Y-axis	500				-	-	-	-	
Z-axis	250		-	-	-	-	-	-	

Dimensions

\* The dimension below is for XY-axis Configuration direction 1.

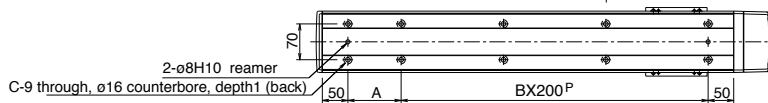
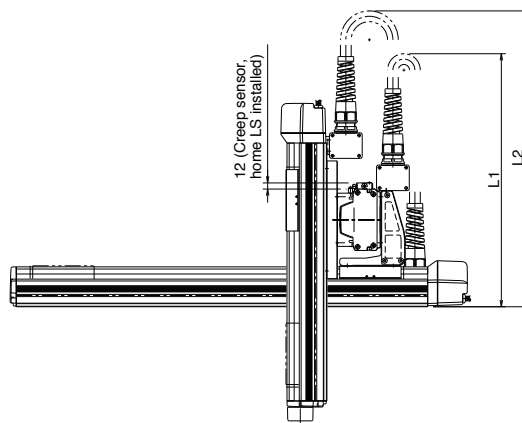
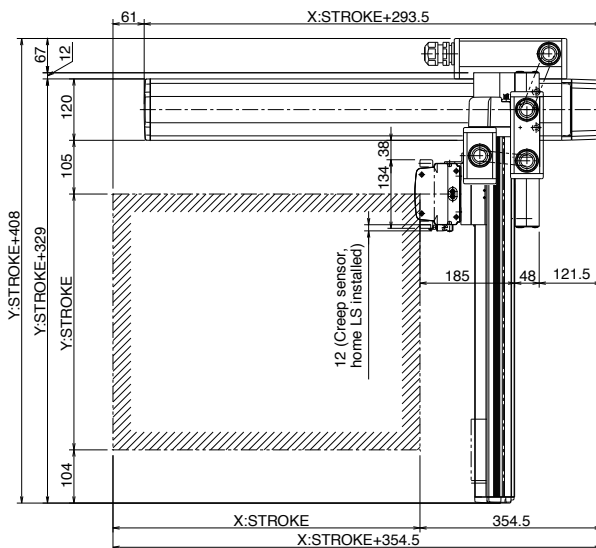
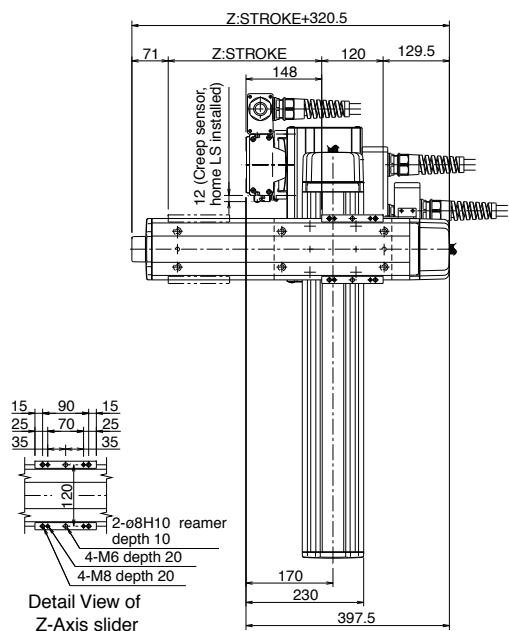

\* The configuration position in the figure is home position. To change the home position, indicate NM in the option. Note that changing the home direction will require the actuator to be returned to IAI for adjustment.

X stroke	200	300	400	500	600	700	800
L1	(550)	(600)	(650)	(700)	(750)	(800)	(850)
A	104	204	104	204	104	204	104
B	1	1	2	2	3	3	4
C	6	6	8	8	10	10	12

Y stroke	100	200	300	400	500
L2	(630)	(680)	(730)	(780)	(830)

<b>ICSA3-BC MB3</b>		Cartesian Robot: X-Y-Z 3-Axes Configuration Z-Axis Base Mount Type	
<b>ICSPA3-BC MB3</b>		Cartesian Robot: X-Y-Z 3-Axes Configuration Z-Axis Base Mount Type High-Precision Specification	
Type	XYB + Z-Axis Base Mount Type	Stroke	X-axis: 200-800mm Y-axis: 100-500mm Z-axis: 100-400mm
Load capacity	19kg - 6.3kg		
Model specification items	Series	Type	Encoder type
(Example)	ICSA3 (ICSPA3)	-BC1MB3M-	A
			- 70AQL - 40AQL - 30BL - T1 - 5L - SC - SC

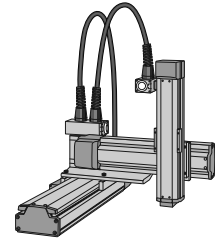

\* Refer to page 51 for the details of model specification items.

**Models/Specifications**

\* [ ] is for the high-precision specification.

Encoder Type	XY-axis configuration direction (*1)	Z-axis type (*2)	Model
Absolute	1	H	ICSA3 [ICSPA3] -BC1MB3H-A-[1]-[2]-[3]-B-T1-[4]-[5]
		M	ICSA3 [ICSPA3] -BC1MB3M-A-[1]-[2]-[3]-B-T1-[4]-[5]
	2	H	ICSA3 [ICSPA3] -BC2MB3H-A-[1]-[2]-[3]-B-T1-[4]-[5]
		M	ICSA3 [ICSPA3] -BC2MB3M-A-[1]-[2]-[3]-B-T1-[4]-[5]
	3	H	ICSA3 [ICSPA3] -BC3MB3H-A-[1]-[2]-[3]-B-T1-[4]-[5]
		M	ICSA3 [ICSPA3] -BC3MB3M-A-[1]-[2]-[3]-B-T1-[4]-[5]
4	H	ICSA3 [ICSPA3] -BC4MB3H-A-[1]-[2]-[3]-B-T1-[4]-[5]	
	M	ICSA3 [ICSPA3] -BC4MB3M-A-[1]-[2]-[3]-B-T1-[4]-[5]	
Incremental	1	H	ICSA3 [ICSPA3] -BC1MB3H-I-[1]-[2]-[3]-B-T1-[4]-[5]
		M	ICSA3 [ICSPA3] -BC1MB3M-I-[1]-[2]-[3]-B-T1-[4]-[5]
	2	H	ICSA3 [ICSPA3] -BC2MB3H-I-[1]-[2]-[3]-B-T1-[4]-[5]
		M	ICSA3 [ICSPA3] -BC2MB3M-I-[1]-[2]-[3]-B-T1-[4]-[5]
	3	H	ICSA3 [ICSPA3] -BC3MB3H-I-[1]-[2]-[3]-B-T1-[4]-[5]
		M	ICSA3 [ICSPA3] -BC3MB3M-I-[1]-[2]-[3]-B-T1-[4]-[5]
	4	H	ICSA3 [ICSPA3] -BC4MB3H-I-[1]-[2]-[3]-B-T1-[4]-[5]
		M	ICSA3 [ICSPA3] -BC4MB3M-I-[1]-[2]-[3]-B-T1-[4]-[5]

\*1: Refer to the figure below for XY-axis configuration direction.  
\*2: The load capacity and the maximum speed may vary depending on the type of Z-axis.  
Note: T1 in the above models will be T2 when operated with XSEL-P/Q type.

**Explanation of Model Code**

Number	Contents	Specification
[1]	X-axis stroke (Note 1)	20 : 200mm ~ 80 : 800mm
[2]	Y-axis stroke (Note 1)	10 : 100mm ~ 50 : 500mm
[3]	Z-axis stroke (Note 1)	10 : 100mm ~ 40 : 400mm
[4]	Cable length (Note 2)	3L : 3m 5L : 5m
[5]	Y-axis/ Z-axis cable management	SC-SC : Self-standing cable CT-CT : Cable track

\* The above explains the Models/Specifications chart to the left.

**Options**

Please add the option codes at the end of each stroke of the axis. When adding multiple options, put together in alphabetic order.

Name	Code	Page
AQ seal	AQ	→P13
Brake	B	→P13
Creep sensor	C	→P13
Home limit switch	L	→P14
Reversed-home specification	NM	→P14
Guide with ball-retaining mechanism	RT	→P14

**Configuration Direction**

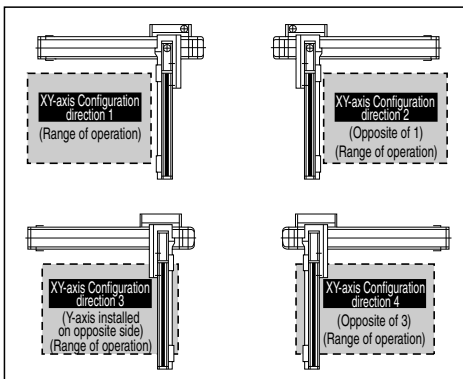

**Common Specifications**

\* [ ] is for the high-precision specification.

Drive system	Ball screw, rolled C10 [equivalent to rolled C5]
Positioning repeatability	±0.02mm [±0.01mm]
Backlash	0.05mm or less [0.02mm or less]
Guide	Integrated with base
Base	Material: Aluminum with white alumite treatment
X-axis motor output / lead	100W / 10mm
Y-axis motor output / lead	100W / 10mm
Z-axis motor output / lead	200W / 20mm (H), 10mm (M)

**Applicable Controller Specifications**

Refer to page 65 for System Configuration.

**Axis Configuration**

\* [ ] is for the high-precision specification.

Axis Type	Model	Page
X-axis	ISA[ISPA]-MXM-[ ]-100-10-(Stroke)-T1	→P18
Y-axis	ISA[ISPA]-MYM-[ ]-100-10-(Stroke)-T1	→P21
Z-axis	ISA[ISPA]-MXM-[ ]-200-20/10-(Stroke)-T1-B	→P19

\*In the above model name, [ ] indicates encoder type A (absolute) or I (incremental).

**Caution**

(Note 1) The stroke in the model is specified in cm (centimeters).  
 (Note 2) The cable length measures from the X-axis connector box to the controller. The standard lengths are 3m and 5m, but other lengths can also be specified in meters. The maximum length is 20m.  
 (Note 3) The rated acceleration is 0.3G. Increasing the acceleration will result in lower load capacity.  
 (Note 4) Please note that a longer stroke will result in a lower maximum speed.

\* For other points to note, please refer to page 49.

ICSA3 [ICSPA3] -BC□MB3□

**Load Capacity (kg) (Note3)**

**BC□MB3H**

		Y-axis stroke				
		100	200	300	400	500
Z-axis stroke	100	9.0				
	200	9.0			8.4	
	300	9.0			7.3	
	400	9.0				

**BC□MB3M**

		Y-axis stroke				
		100	200	300	400	500
Z-axis stroke	100	19.0	18.5	17.5	12.5	9.4
	200	18.5	17.5	16.5	11.5	8.4
	300	17.4	16.4	15.4	10.4	7.3
	400	16.4	15.4	14.4	9.4	6.3

**Maximum Speed by Stroke (mm/sec) (Note4)**

**BC□MB3H**

	Stroke								
	100	200	300	400	500	600	700	800	
X-axis	-	500					480		380
Y-axis	500				-	-	-	-	-
Z-axis	1000		-	-	-	-	-	-	

**BC□MB3M**

	Stroke								
	100	200	300	400	500	600	700	800	
X-axis	-	500					480		380
Y-axis	500				-	-	-	-	
Z-axis	500		-	-	-	-	-	-	

**Dimensions**

\* The dimension below is for XY-axis Configuration direction 1.

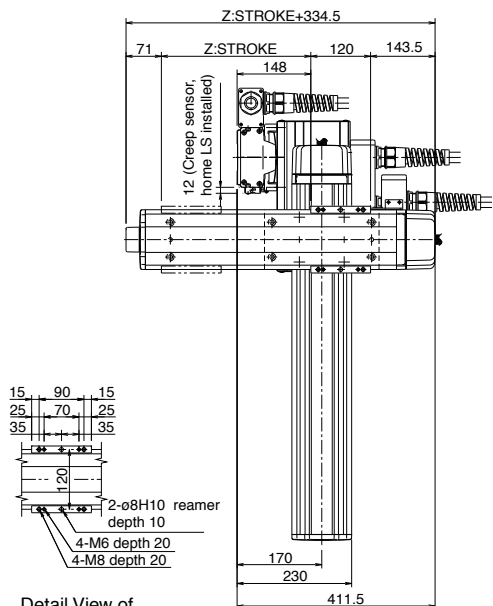

Detail View of Z-Axis slider

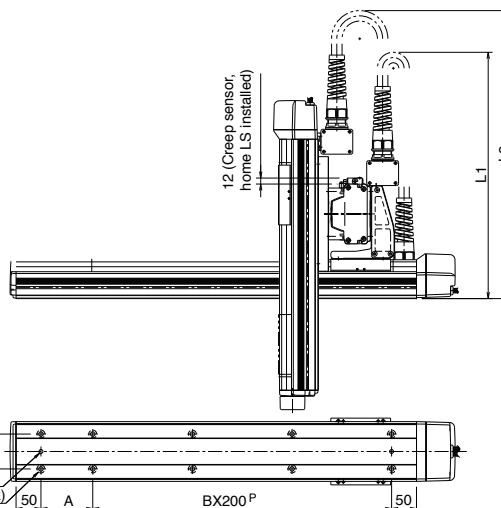
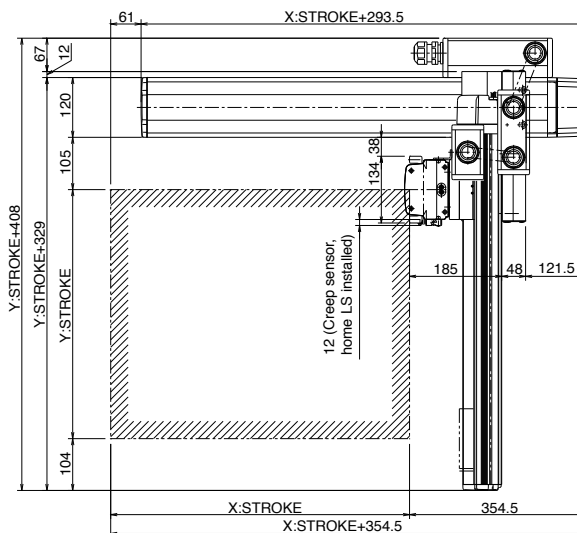

\* The configuration position in the figure is home position. To change the home position, indicate NM in the option. Note that changing the home direction will require the actuator to be returned to IAI for adjustment.

X stroke	200	300	400	500	600	700	800
L1	(550)	(600)	(650)	(700)	(750)	(800)	(850)
A	104	204	104	204	104	204	104
B	1	1	2	2	3	3	4
C	6	6	8	8	10	10	12

Y stroke	100	200	300	400	500
L2	(630)	(680)	(730)	(780)	(830)

<b>ICSA3-BD</b> <input type="checkbox"/> <b>HB1</b> <input type="checkbox"/>		Cartesian Robot: X-Y-Z 3-Axes Configuration Z-Axis Base Mount Type
<b>ICSPA3-BD</b> <input type="checkbox"/> <b>HB1</b> <input type="checkbox"/>		Cartesian Robot: X-Y-Z 3-Axes Configuration Z-Axis Base Mount Type High-Precision Specification
Type	XYB + Z-Axis Base Mount Type	Stroke X-axis: 800-2000mm Y-axis: 100-500mm Z-axis: 100-400mm
		Load capacity 14kg ~ 3kg
Model specification items	Series	Type Encoder type X-axis stroke + options Y-axis stroke + options Z-axis stroke + options Applicable controller Cable length Cable management
(Example)	ICSA3 (ICSPA3)	-BD1HB1M-A - A - 100AQL - 40AQL - 30BL - T1 - 5L - CT - SC

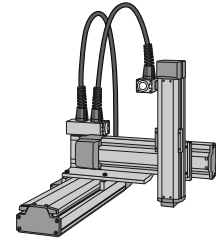

\* Refer to page 51 for the details of model specification items.

**Models/Specifications**

\* [ ] is for the high-precision specification.

Encoder Type	XY-axis configuration direction (*1)	Z-axis type (*2)	Model
Absolute	1	H	ICSA3 [ICSPA3] -BD1HB1H-A- <input type="checkbox"/> - <input type="checkbox"/> - <input type="checkbox"/> -B-T1- <input type="checkbox"/> - <input type="checkbox"/>
		M	ICSA3 [ICSPA3] -BD1HB1M-A- <input type="checkbox"/> - <input type="checkbox"/> - <input type="checkbox"/> -B-T1- <input type="checkbox"/> - <input type="checkbox"/>
		L	ICSA3 [ICSPA3] -BD1HB1L-A- <input type="checkbox"/> - <input type="checkbox"/> - <input type="checkbox"/> -B-T1- <input type="checkbox"/> - <input type="checkbox"/>
	2	H	ICSA3 [ICSPA3] -BD2HB1H-A- <input type="checkbox"/> - <input type="checkbox"/> - <input type="checkbox"/> -B-T1- <input type="checkbox"/> - <input type="checkbox"/>
		M	ICSA3 [ICSPA3] -BD2HB1M-A- <input type="checkbox"/> - <input type="checkbox"/> - <input type="checkbox"/> -B-T1- <input type="checkbox"/> - <input type="checkbox"/>
		L	ICSA3 [ICSPA3] -BD2HB1L-A- <input type="checkbox"/> - <input type="checkbox"/> - <input type="checkbox"/> -B-T1- <input type="checkbox"/> - <input type="checkbox"/>
	3	H	ICSA3 [ICSPA3] -BD3HB1H-A- <input type="checkbox"/> - <input type="checkbox"/> - <input type="checkbox"/> -B-T1- <input type="checkbox"/> - <input type="checkbox"/>
		M	ICSA3 [ICSPA3] -BD3HB1M-A- <input type="checkbox"/> - <input type="checkbox"/> - <input type="checkbox"/> -B-T1- <input type="checkbox"/> - <input type="checkbox"/>
		L	ICSA3 [ICSPA3] -BD3HB1L-A- <input type="checkbox"/> - <input type="checkbox"/> - <input type="checkbox"/> -B-T1- <input type="checkbox"/> - <input type="checkbox"/>
	4	H	ICSA3 [ICSPA3] -BD4HB1H-A- <input type="checkbox"/> - <input type="checkbox"/> - <input type="checkbox"/> -B-T1- <input type="checkbox"/> - <input type="checkbox"/>
		M	ICSA3 [ICSPA3] -BD4HB1M-A- <input type="checkbox"/> - <input type="checkbox"/> - <input type="checkbox"/> -B-T1- <input type="checkbox"/> - <input type="checkbox"/>
		L	ICSA3 [ICSPA3] -BD4HB1L-A- <input type="checkbox"/> - <input type="checkbox"/> - <input type="checkbox"/> -B-T1- <input type="checkbox"/> - <input type="checkbox"/>
Incremental	1	H	ICSA3 [ICSPA3] -BD1HB1H-I- <input type="checkbox"/> - <input type="checkbox"/> - <input type="checkbox"/> -B-T1- <input type="checkbox"/> - <input type="checkbox"/>
		M	ICSA3 [ICSPA3] -BD1HB1M-I- <input type="checkbox"/> - <input type="checkbox"/> - <input type="checkbox"/> -B-T1- <input type="checkbox"/> - <input type="checkbox"/>
		L	ICSA3 [ICSPA3] -BD1HB1L-I- <input type="checkbox"/> - <input type="checkbox"/> - <input type="checkbox"/> -B-T1- <input type="checkbox"/> - <input type="checkbox"/>
	2	H	ICSA3 [ICSPA3] -BD2HB1H-I- <input type="checkbox"/> - <input type="checkbox"/> - <input type="checkbox"/> -B-T1- <input type="checkbox"/> - <input type="checkbox"/>
		M	ICSA3 [ICSPA3] -BD2HB1M-I- <input type="checkbox"/> - <input type="checkbox"/> - <input type="checkbox"/> -B-T1- <input type="checkbox"/> - <input type="checkbox"/>
		L	ICSA3 [ICSPA3] -BD2HB1L-I- <input type="checkbox"/> - <input type="checkbox"/> - <input type="checkbox"/> -B-T1- <input type="checkbox"/> - <input type="checkbox"/>
	3	H	ICSA3 [ICSPA3] -BD3HB1H-I- <input type="checkbox"/> - <input type="checkbox"/> - <input type="checkbox"/> -B-T1- <input type="checkbox"/> - <input type="checkbox"/>
		M	ICSA3 [ICSPA3] -BD3HB1M-I- <input type="checkbox"/> - <input type="checkbox"/> - <input type="checkbox"/> -B-T1- <input type="checkbox"/> - <input type="checkbox"/>
		L	ICSA3 [ICSPA3] -BD3HB1L-I- <input type="checkbox"/> - <input type="checkbox"/> - <input type="checkbox"/> -B-T1- <input type="checkbox"/> - <input type="checkbox"/>
	4	H	ICSA3 [ICSPA3] -BD4HB1H-I- <input type="checkbox"/> - <input type="checkbox"/> - <input type="checkbox"/> -B-T1- <input type="checkbox"/> - <input type="checkbox"/>
		M	ICSA3 [ICSPA3] -BD4HB1M-I- <input type="checkbox"/> - <input type="checkbox"/> - <input type="checkbox"/> -B-T1- <input type="checkbox"/> - <input type="checkbox"/>
		L	ICSA3 [ICSPA3] -BD4HB1L-I- <input type="checkbox"/> - <input type="checkbox"/> - <input type="checkbox"/> -B-T1- <input type="checkbox"/> - <input type="checkbox"/>

\*1: Refer to the figure below for XY-axis configuration direction.  
\*2: The load capacity and the maximum speed may vary depending on the type of Z-axis.  
Note: T1 in the above models will be T2 when operated with XSEL-P/G type.

**Explanation of Model Code**

Number	Contents	Specification
①	X-axis stroke (Note 1)	80 : 800mm ~ 200 : 2000mm
②	Y-axis stroke (Note 1)	10 : 100mm ~ 50 : 500mm
③	Z-axis stroke (Note 1)	10 : 100mm ~ 40 : 400mm
④	Cable length (Note 2)	3L : 3m 5L : 5m
⑤	Y-axis/ Z-axis cable management	CT-SC : Self-standing cable (*3) CT-CT : Cable track

\* The above explains the Models/Specifications chart to the left.  
\*3 Only cable track can be specified for the Y-axis cable management with model # BD□HB1□.

**Options**

Please add the option codes at the end of each stroke of the axis. When adding multiple options, put together in alphabetic order.

Name	Code	Page
AQ seal	AQ	→P13
Brake	B	→P13
Creep sensor	C	→P13
Home limit switch	L	→P14
Reversed-home specification	NM	→P14
Guide with ball-retaining mechanism	RT	→P14

**Configuration Direction**

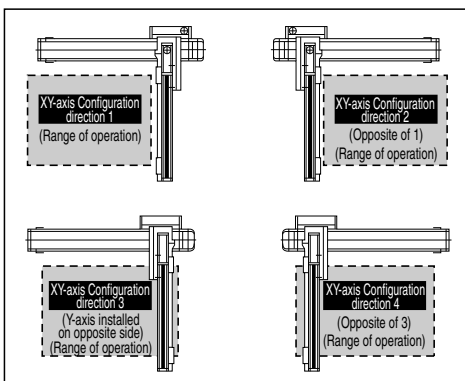

**Common Specifications**

\* [ ] is for the high-precision specification.

Drive system	Ball screw, rolled C10 [equivalent to rolled C5]
Positioning repeatability	±0.02mm [±0.01mm]
Backlash	0.05mm or less [0.02mm or less]
Guide	Integrated with base
Base	Material: Aluminum with white alumite treatment
X-axis motor output / lead	200W / 20mm
Y-axis motor output / lead	100W / 20mm
Z-axis motor output / lead	60W / 16mm (H), 8mm (M), 4mm (L)

**Applicable Controller Specifications**

Refer to page 65 for System Configuration.

**Axis Configuration**

\* [ ] is for the high-precision specification.

Axis Type	Model	Page
X-axis	ISA[ISPA]-MXMX-□-200-20-(Stroke)-T1	→P20
Y-axis	ISA[ISPA]-MYM-□-100-20-(Stroke)-T1	→P21
Z-axis	ISA[ISPA]-SXM-□-60-16/8/4-(Stroke)-T1-B	→P15

\*In the above model name, □ indicates encoder type A (absolute) or I (incremental).

**Caution**

(Note 1) The stroke in the model is specified in cm (centimeters).  
 (Note 2) The cable length measures from the X-axis connector box to the controller. The standard lengths are 3m and 5m, but other lengths can also be specified in meters. The maximum length is 20m.  
 (Note 3) The rated acceleration is 0.3G. Increasing the acceleration will result in lower load capacity.  
 (Note 4) Please note that a longer stroke will result in a lower maximum speed.

\* For other points to note, please refer to page 49.



ICSA3 [ICSPA3] -BD□HB1□

Single-Axis Robots

Cartesian Robots

Controllers

**Load Capacity (kg) (Note3)**

■BD□HB1H

		Y-axis stroke				
		100	200	300	400	500
Z-axis stroke	100	3.0				
	200	3.0				
	300	3.0				
	400	3.0				

■BD□HB1M

		Y-axis stroke				
		100	200	300	400	500
Z-axis stroke	100	6.0				
	200	6.0				
	300	6.0				
	400	6.0				

■BD□HB1L

		Y-axis stroke				
		100	200	300	400	500
Z-axis stroke	100	14.0				13.5
	200	14.0				12.9
	300	14.0				12.3
	300	13.5				11.7

**Maximum Speed by Stroke (mm/sec) (Note4)**

■BD□HB1H

	Stroke									
	100 ~ 400	500	800 ~ 1300	1400	1500	1600	1700	1800	1900	2000
X-axis	-	-	1000	950	800	700	600	550	500	450
Y-axis	1000									
Z-axis	800	-	-	-	-	-	-	-	-	-

■BD□HB1M

	Stroke									
	100 ~ 400	500	800 ~ 1300	1400	1500	1600	1700	1800	1900	2000
X-axis	-	-	1000	950	800	700	600	550	500	450
Y-axis	1000									
Z-axis	400	-	-	-	-	-	-	-	-	-

■BD□HB1L

	Stroke									
	100 ~ 400	500	800 ~ 1300	1400	1500	1600	1700	1800	1900	2000
X-axis	-	-	1000	950	800	700	600	550	500	450
Y-axis	1000									
Z-axis	200	-	-	-	-	-	-	-	-	-

**Dimensions** \* The dimension below is for XY-axis Configuration direction 1.

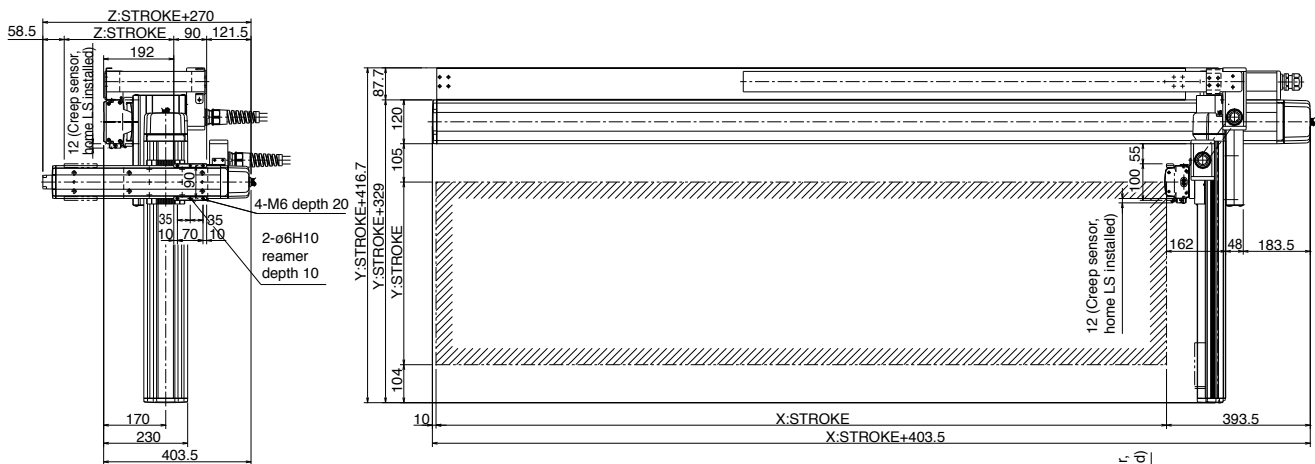

\* The configuration position in the figure is home position. To change the home position, indicate NM in the option. Note that changing the home direction will require the actuator to be returned to IAI for adjustment.

X st	800	900	1000	1100	1200	1300	1400	1500	1600	1700	1800	1900	2000
A	0	0	200	250	300	350	400	450	500	550	200	200	200
B	0	0	0	0	0	0	0	0	0	0	400	450	500
C	200	200	200	250	300	350	400	450	500	550	200	200	200
D	10	10	12	12	12	12	12	12	12	12	16	16	16

Y st	100	200	300	400	500
L	(590)	(640)	(690)	(740)	(790)

<b>ICSA3-BD</b> <input type="checkbox"/> <b>HB2</b> <input type="checkbox"/>		Cartesian Robot: X-Y-Z 3-Axes Configuration Z-Axis Base Mount Type
<b>ICSPA3-BD</b> <input type="checkbox"/> <b>HB2</b> <input type="checkbox"/>		Cartesian Robot: X-Y-Z 3-Axes Configuration Z-Axis Base Mount Type High-Precision Specification
Type	XYB + Z-Axis Base Mount Type	Stroke X-axis: 800-2000mm Y-axis: 100-500mm Z-axis: 100-400mm
		Load capacity 10.7kg ~ 3.5kg
Model specification items	Series	Type Encoder type X-axis stroke + options Y-axis stroke + options Z-axis stroke + options Applicable controller Cable length Cable management
(Example)	ICSA3 (ICSPA3)	-BD1HB2M- A - 100AQL - 40AQL - 30BL - T1 - 5L - CT - SC

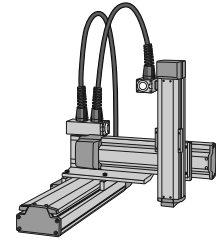

\* Refer to page 51 for the details of model specification items.

**Models/Specifications**

\* [ ] is for the high-precision specification.

Encoder Type	XY-axis configuration direction (*1)	Z-axis type (*2)	Model
Absolute	1	H	ICSA3 [ICSPA3] -BD1HB2H-A- [1] - [2] - [3] -B-T1- [4] - [5]
		M	ICSA3 [ICSPA3] -BD1HB2M-A- [1] - [2] - [3] -B-T1- [4] - [5]
		L	ICSA3 [ICSPA3] -BD1HB2L-A- [1] - [2] - [3] -B-T1- [4] - [5]
	2	H	ICSA3 [ICSPA3] -BD2HB2H-A- [1] - [2] - [3] -B-T1- [4] - [5]
		M	ICSA3 [ICSPA3] -BD2HB2M-A- [1] - [2] - [3] -B-T1- [4] - [5]
		L	ICSA3 [ICSPA3] -BD2HB2L-A- [1] - [2] - [3] -B-T1- [4] - [5]
	3	H	ICSA3 [ICSPA3] -BD3HB2H-A- [1] - [2] - [3] -B-T1- [4] - [5]
		M	ICSA3 [ICSPA3] -BD3HB2M-A- [1] - [2] - [3] -B-T1- [4] - [5]
		L	ICSA3 [ICSPA3] -BD3HB2L-A- [1] - [2] - [3] -B-T1- [4] - [5]
	4	H	ICSA3 [ICSPA3] -BD4HB2H-A- [1] - [2] - [3] -B-T1- [4] - [5]
		M	ICSA3 [ICSPA3] -BD4HB2M-A- [1] - [2] - [3] -B-T1- [4] - [5]
		L	ICSA3 [ICSPA3] -BD4HB2L-A- [1] - [2] - [3] -B-T1- [4] - [5]
Incremental	1	H	ICSA3 [ICSPA3] -BD1HB2H-I- [1] - [2] - [3] -B-T1- [4] - [5]
		M	ICSA3 [ICSPA3] -BD1HB2M-I- [1] - [2] - [3] -B-T1- [4] - [5]
		L	ICSA3 [ICSPA3] -BD1HB2L-I- [1] - [2] - [3] -B-T1- [4] - [5]
	2	H	ICSA3 [ICSPA3] -BD2HB2H-I- [1] - [2] - [3] -B-T1- [4] - [5]
		M	ICSA3 [ICSPA3] -BD2HB2M-I- [1] - [2] - [3] -B-T1- [4] - [5]
		L	ICSA3 [ICSPA3] -BD2HB2L-I- [1] - [2] - [3] -B-T1- [4] - [5]
	3	H	ICSA3 [ICSPA3] -BD3HB2H-I- [1] - [2] - [3] -B-T1- [4] - [5]
		M	ICSA3 [ICSPA3] -BD3HB2M-I- [1] - [2] - [3] -B-T1- [4] - [5]
		L	ICSA3 [ICSPA3] -BD3HB2L-I- [1] - [2] - [3] -B-T1- [4] - [5]
	4	H	ICSA3 [ICSPA3] -BD4HB2H-I- [1] - [2] - [3] -B-T1- [4] - [5]
		M	ICSA3 [ICSPA3] -BD4HB2M-I- [1] - [2] - [3] -B-T1- [4] - [5]
		L	ICSA3 [ICSPA3] -BD4HB2L-I- [1] - [2] - [3] -B-T1- [4] - [5]

\*1: Refer to the figure below for XY-axis configuration direction.  
\*2: The load capacity and the maximum speed may vary depending on the type of Z-axis.  
Note: T1 in the above models will be T2 when operated with XSEL-P/G type.

**Explanation of Model Code**

Number	Contents	Specification
[1]	X-axis stroke (Note 1)	80 : 800mm ~ 200 : 2000mm
[2]	Y-axis stroke (Note 1)	10 : 100mm ~ 50 : 500mm
[3]	Z-axis stroke (Note 1)	10 : 100mm ~ 40 : 400mm
[4]	Cable length (Note 2)	3L : 3m 5L : 5m
[5]	Y-axis/ Z-axis cable management	CT-SC : Self-standing cable (*3) CT-CT : Cable track

\* The above explains the Models/Specifications chart to the left.  
\*3 Only cable track can be specified for the Y-axis cable management with model # BD□HB2□.

**Options**

Please add the option codes at the end of each stroke of the axis. When adding multiple options, put together in alphabetic order.

Name	Code	Page
AQ seal	AQ	→P13
Brake	B	→P13
Creep sensor	C	→P13
Home limit switch	L	→P14
Reversed-home specification	NM	→P14
Guide with ball-retaining mechanism	RT	→P14

**Configuration Direction**

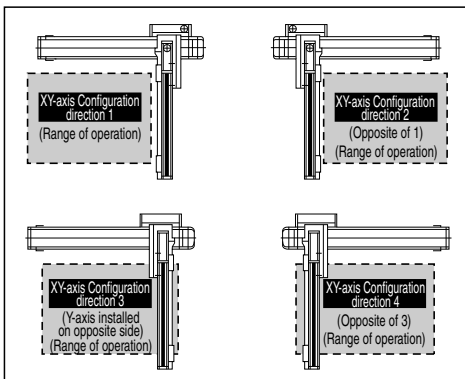

**Common Specifications**

\* [ ] is for the high-precision specification.

Drive system	Ball screw, rolled C10 [equivalent to rolled C5]
Positioning repeatability	±0.02mm [±0.01mm]
Backlash	0.05mm or less [0.02mm or less]
Guide	Integrated with base
Base	Material: Aluminum with white alumite treatment
X-axis motor output / lead	200W / 20mm
Y-axis motor output / lead	100W / 20mm
Z-axis motor output / lead	100W / 20mm (H), 10mm (M), 5mm (L)

**Applicable Controller Specifications**

Refer to page 65 for System Configuration.

**Axis Configuration**

\* [ ] is for the high-precision specification.

Axis Type	Model	Page
X-axis	ISA[ISPA]-MXMX-□-200-20-(Stroke)-T1	→P20
Y-axis	ISA[ISPA]-MYM-□-100-20-(Stroke)-T1	→P21
Z-axis	ISA[ISPA]-MXM-□-100-20/10/5-(Stroke)-T1-B	→P18

\*In the above model name, □ indicates encoder type A (absolute) or I (incremental).

**Caution**

(Note 1) The stroke in the model is specified in cm (centimeters).  
 (Note 2) The cable length measures from the X-axis connector box to the controller. The standard lengths are 3m and 5m, but other lengths can also be specified in meters. The maximum length is 20m.  
 (Note 3) The rated acceleration is 0.3G. Increasing the acceleration will result in lower load capacity.  
 (Note 4) Please note that a longer stroke will result in a lower maximum speed.

\* For other points to note, please refer to page 49.

ICSA3 [ICSPA3] -BD□HB2□

Single-Axis Robots

Cartesian Robots

Controllers

**Load Capacity (kg) (Note3)**

■BD□HB2H

		Y-axis stroke				
		100	200	300	400	500
Z-axis stroke	100	3.5				
	200	3.5				
	300	3.5				
	400	3.5				

■BD□HB2M

		Y-axis stroke				
		100	200	300	400	500
Z-axis stroke	100	9.0				
	200	9.0			8.4	
	300	8.6			7.3	
	400	7.6			6.3	

■BD□HB2L

		Y-axis stroke				
		100	200	300	400	500
Z-axis stroke	100	10.7			9.4	
	200	9.7			8.4	
	300	8.6			7.3	
	300	7.6			6.3	

**Maximum Speed by Stroke (mm/sec) (Note4)**

■BD□HB2H

	Stroke									
	100 ~ 400	500	800 ~ 1300	1400	1500	1600	1700	1800	1900	2000
X-axis	-	-	1000	950	800	700	600	550	500	450
Y-axis	1000		-	-	-	-	-	-	-	-
Z-axis	1000	-	-	-	-	-	-	-	-	-

■BD□HB2M

	Stroke									
	100 ~ 400	500	800 ~ 1300	1400	1500	1600	1700	1800	1900	2000
X-axis	-	-	1000	950	800	700	600	550	500	450
Y-axis	1000		-	-	-	-	-	-	-	-
Z-axis	500	-	-	-	-	-	-	-	-	-

■BD□HB2L

	Stroke									
	100 ~ 400	500	800 ~ 1300	1400	1500	1600	1700	1800	1900	2000
X-axis	-	-	1000	950	800	700	600	550	500	450
Y-axis	1000		-	-	-	-	-	-	-	-
Z-axis	250	-	-	-	-	-	-	-	-	-

**Dimensions**

\* The dimension below is for XY-axis Configuration direction 1.

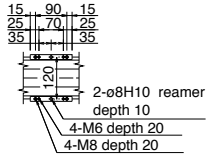
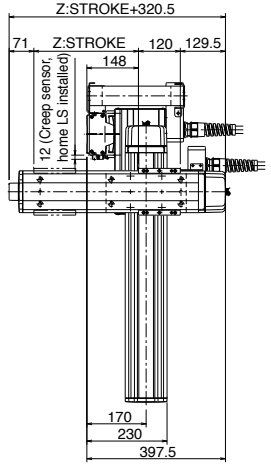

Detail View of Z-Axis slider

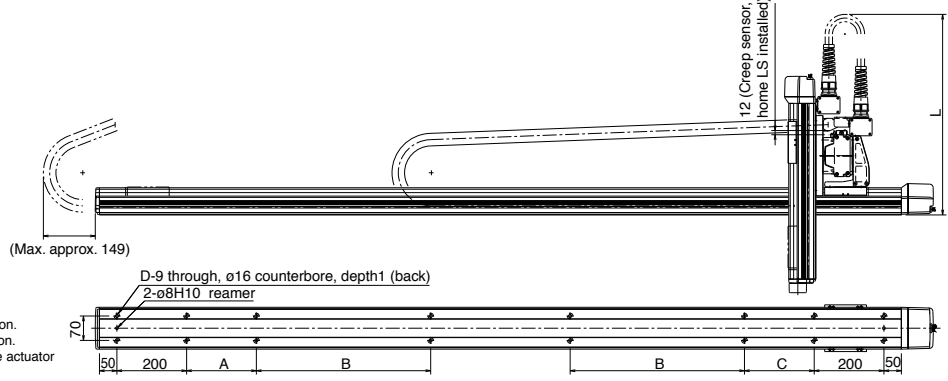
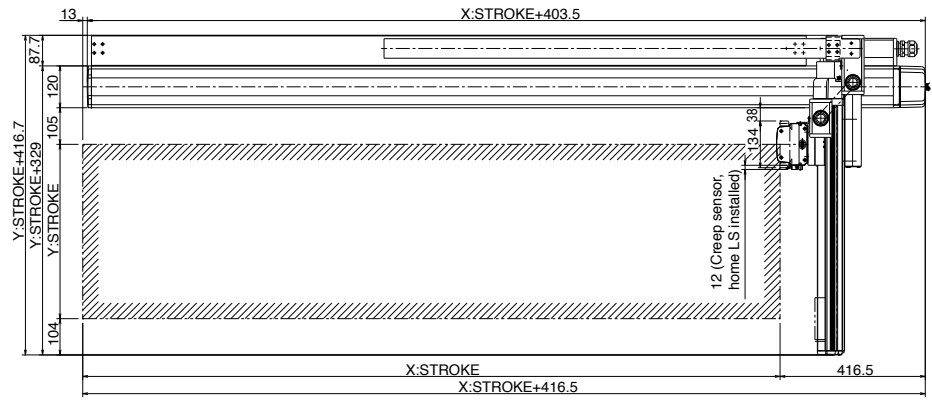

\* The configuration position in the figure is home position. To change the home position, indicate NM in the option. Note that changing the home direction will require the actuator to be returned to IAI for adjustment.

X st	800	900	1000	1100	1200	1300	1400	1500	1600	1700	1800	1900	2000
A	0	0	200	250	300	350	400	450	500	550	200	200	200
B	0	0	0	0	0	0	0	0	0	0	400	450	500
C	200	200	200	250	300	350	400	450	500	550	200	200	200
D	10	10	12	12	12	12	12	12	12	12	16	16	16

Y st	100	200	300	400	500
L	(590)	(640)	(690)	(740)	(790)

<b>ICSA3-BD</b> <input type="checkbox"/> <b>HB3</b> <input type="checkbox"/>		Cartesian Robot: X-Y-Z 3-Axes Configuration Z-Axis Base Mount Type
<b>ICSPA3-BD</b> <input type="checkbox"/> <b>HB3</b> <input type="checkbox"/>		Cartesian Robot: X-Y-Z 3-Axes Configuration Z-Axis Base Mount Type High-Precision Specification
Type	XYB + Z-Axis Base Mount Type	Stroke X-axis: 800-2000mm Y-axis: 100-500mm Z-axis: 100-400mm
Load capacity	10.7kg ~ 6.3kg	
Model specification items	Series - Type - Encoder type - X-axis stroke + options - Y-axis stroke + options - Z-axis stroke + options - Applicable controller - Cable length - Cable management	
(Example)	ICSA3 (ICSPA3) - BD1HB3M - A - 100AQL - 40AQL - 30BL - T1 - 5L - CT - SC	

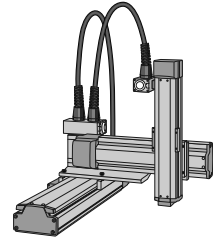

\* Refer to page 51 for the details of model specification items.

**Models/Specifications** \* [ ] is for the high-precision specification.

Encoder Type	XY-axis configuration direction (*1)	Z-axis type (*2)	Model
Absolute	1	H	ICSA3 [ICSPA3] -BD1HB3H-A- <input type="checkbox"/> - <input type="checkbox"/> - <input type="checkbox"/> -B-T1- <input type="checkbox"/> - <input type="checkbox"/>
		M	ICSA3 [ICSPA3] -BD1HB3M-A- <input type="checkbox"/> - <input type="checkbox"/> - <input type="checkbox"/> -B-T1- <input type="checkbox"/> - <input type="checkbox"/>
	2	H	ICSA3 [ICSPA3] -BD2HB3H-A- <input type="checkbox"/> - <input type="checkbox"/> - <input type="checkbox"/> -B-T1- <input type="checkbox"/> - <input type="checkbox"/>
		M	ICSA3 [ICSPA3] -BD2HB3M-A- <input type="checkbox"/> - <input type="checkbox"/> - <input type="checkbox"/> -B-T1- <input type="checkbox"/> - <input type="checkbox"/>
	3	H	ICSA3 [ICSPA3] -BD3HB3H-A- <input type="checkbox"/> - <input type="checkbox"/> - <input type="checkbox"/> -B-T1- <input type="checkbox"/> - <input type="checkbox"/>
		M	ICSA3 [ICSPA3] -BD3HB3M-A- <input type="checkbox"/> - <input type="checkbox"/> - <input type="checkbox"/> -B-T1- <input type="checkbox"/> - <input type="checkbox"/>
	4	H	ICSA3 [ICSPA3] -BD4HB3H-A- <input type="checkbox"/> - <input type="checkbox"/> - <input type="checkbox"/> -B-T1- <input type="checkbox"/> - <input type="checkbox"/>
		M	ICSA3 [ICSPA3] -BD4HB3M-A- <input type="checkbox"/> - <input type="checkbox"/> - <input type="checkbox"/> -B-T1- <input type="checkbox"/> - <input type="checkbox"/>
Incremental	1	H	ICSA3 [ICSPA3] -BD1HB3H-I- <input type="checkbox"/> - <input type="checkbox"/> - <input type="checkbox"/> -B-T1- <input type="checkbox"/> - <input type="checkbox"/>
		M	ICSA3 [ICSPA3] -BD1HB3M-I- <input type="checkbox"/> - <input type="checkbox"/> - <input type="checkbox"/> -B-T1- <input type="checkbox"/> - <input type="checkbox"/>
	2	H	ICSA3 [ICSPA3] -BD2HB3H-I- <input type="checkbox"/> - <input type="checkbox"/> - <input type="checkbox"/> -B-T1- <input type="checkbox"/> - <input type="checkbox"/>
		M	ICSA3 [ICSPA3] -BD2HB3M-I- <input type="checkbox"/> - <input type="checkbox"/> - <input type="checkbox"/> -B-T1- <input type="checkbox"/> - <input type="checkbox"/>
	3	H	ICSA3 [ICSPA3] -BD3HB3H-I- <input type="checkbox"/> - <input type="checkbox"/> - <input type="checkbox"/> -B-T1- <input type="checkbox"/> - <input type="checkbox"/>
		M	ICSA3 [ICSPA3] -BD3HB3M-I- <input type="checkbox"/> - <input type="checkbox"/> - <input type="checkbox"/> -B-T1- <input type="checkbox"/> - <input type="checkbox"/>
	4	H	ICSA3 [ICSPA3] -BD4HB3H-I- <input type="checkbox"/> - <input type="checkbox"/> - <input type="checkbox"/> -B-T1- <input type="checkbox"/> - <input type="checkbox"/>
		M	ICSA3 [ICSPA3] -BD4HB3M-I- <input type="checkbox"/> - <input type="checkbox"/> - <input type="checkbox"/> -B-T1- <input type="checkbox"/> - <input type="checkbox"/>

\*1: Refer to the figure below for XY-axis configuration direction.  
 \*2: The load capacity and the maximum speed may vary depending on the type of Z-axis.  
 Note: T1 in the above models will be T2 when operated with XSEL-P/Q type.

**Explanation of Model Code**

Number	Contents	Specification
<input type="checkbox"/>	X-axis stroke (Note 1)	80 : 800mm ~ 200 : 2000mm
<input type="checkbox"/>	Y-axis stroke (Note 1)	10 : 100mm ~ 50 : 500mm
<input type="checkbox"/>	Z-axis stroke (Note 1)	10 : 100mm ~ 40 : 400mm
<input type="checkbox"/>	Cable length (Note 2)	3L : 3m 5L : 5m
<input type="checkbox"/>	Y-axis/ Z-axis cable management	CT-SC : Self-standing cable (*3) CT-CT : Cable track

\* The above explains the Models/Specifications chart to the left.  
 \*3 Only cable track can be specified for the Y-axis cable management with model # BDHB3.

**Options**

Please add the option codes at the end of each stroke of the axis.  
 When adding multiple options, put together in alphabetic order.

Name	Code	Page
AQ seal	AQ	→P13
Brake	B	→P13
Creep sensor	C	→P13
Home limit switch	L	→P14
Reversed-home specification	NM	→P14
Guide with ball-retaining mechanism	RT	→P14

**Configuration Direction**

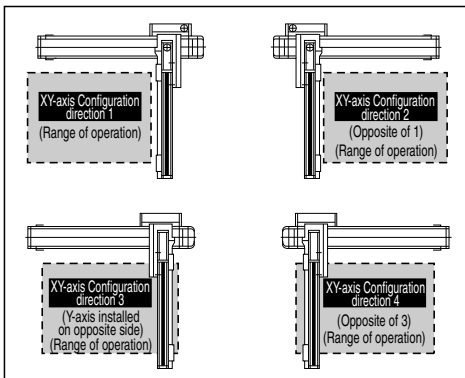

**Common Specifications** \* [ ] is for the high-precision specification.

Drive system	Ball screw, rolled C10 [equivalent to rolled C5]
Positioning repeatability	±0.02mm [±0.01mm]
Backlash	0.05mm or less [0.02mm or less]
Guide	Integrated with base
Base	Material: Aluminum with white alumite treatment
X-axis motor output / lead	200W / 20mm
Y-axis motor output / lead	100W / 20mm
Z-axis motor output / lead	200W / 20mm (H), 10mm (M)

**Applicable Controller Specifications**

Refer to page 65 for System Configuration.

**Axis Configuration** \* [ ] is for the high-precision specification.

Axis Type	Model	Page
X-axis	ISA[ISPA]-MXMX- <input type="checkbox"/> -200-20-(Stroke)-T1	→P20
Y-axis	ISA[ISPA]-MYM- <input type="checkbox"/> -100-20-(Stroke)-T1	→P21
Z-axis	ISA[ISPA]-MXM- <input type="checkbox"/> -200-20/10-(Stroke)-T1-B	→P19

\*In the above model name,  indicates encoder type A (absolute) or I (incremental).

**Caution**

(Note 1) The stroke in the model is specified in cm (centimeters).  
 (Note 2) The cable length measures from the X-axis connector box to the controller. The standard lengths are 3m and 5m, but other lengths can also be specified in meters. The maximum length is 20m.  
 (Note 3) The rated acceleration is 0.3G. Increasing the acceleration will result in lower load capacity.  
 (Note 4) Please note that a longer stroke will result in a lower maximum speed.

\* For other points to note, please refer to page 49.

ICSA3 [ICSPA3] -BD□HB3□

Load Capacity (kg) (Note3)

BD□HB3H

		Y-axis stroke				
		100	200	300	400	500
Z-axis stroke	100	9.0				
	200	9.0			8.4	
	300	8.6			7.3	
	400	7.6			6.3	

BD□HB3M

		Y-axis stroke				
		100	200	300	400	500
Z-axis stroke	100	10.7			9.4	
	200	9.7			8.4	
	300	8.6			7.3	
	400	7.6			6.3	

Maximum Speed by Stroke (mm/sec) (Note4)

BD□HB3H

	Stroke									
	100 ~ 400	500	800 ~ 1300	1400	1500	1600	1700	1800	1900	2000
X-axis	-	-	1000	950	800	700	600	550	500	450
Y-axis	1000		-	-	-	-	-	-	-	-
Z-axis	1000	-	-	-	-	-	-	-	-	-

BD□HB3M

	Stroke									
	100 ~ 400	500	800 ~ 1300	1400	1500	1600	1700	1800	1900	2000
X-axis	-	-	1000	950	800	700	600	550	500	450
Y-axis	1000		-	-	-	-	-	-	-	-
Z-axis	500	-	-	-	-	-	-	-	-	-

Dimensions

\* The dimension below is for XY-axis Configuration direction 1.

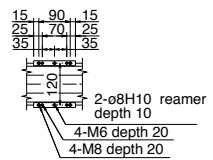
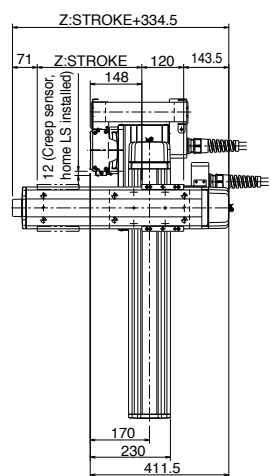

Detail View of Z-Axis slider

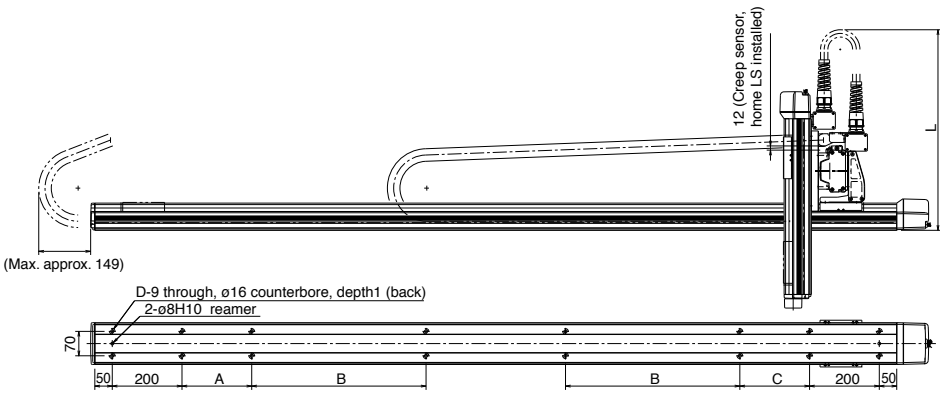
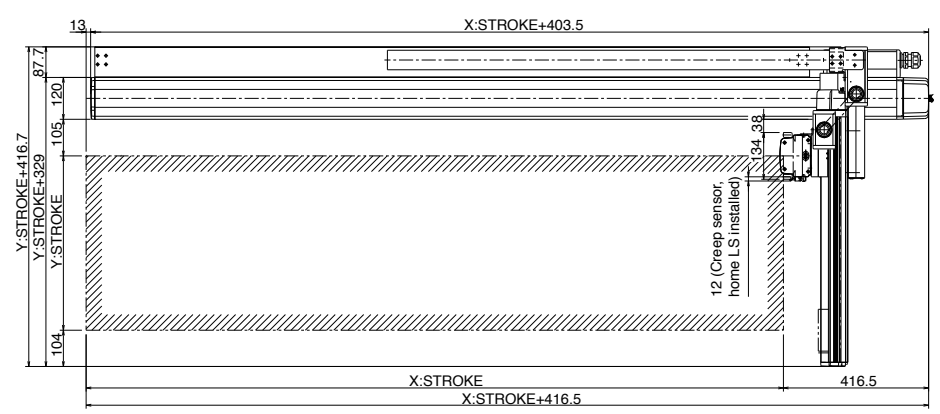

\* The configuration position in the figure is home position. To change the home position, indicate NM in the option. Note that changing the home direction will require the actuator to be returned to IAI for adjustment.

X st	800	900	1000	1100	1200	1300	1400	1500	1600	1700	1800	1900	2000
A	0	0	200	250	300	350	400	450	500	550	200	200	200
B	0	0	0	0	0	0	0	0	0	0	400	450	500
C	200	200	200	250	300	350	400	450	500	550	200	200	200
D	10	10	12	12	12	12	12	12	12	12	16	16	16

Y st	100	200	300	400	500
L	(590)	(640)	(690)	(740)	(790)

<b>ICSA3-BE</b> <input type="checkbox"/> <b>HB1</b> <input type="checkbox"/>		Cartesian Robot: X-Y-Z 3-Axes Configuration Z-Axis Base Mount Type	
<b>ICSPA3-BE</b> <input type="checkbox"/> <b>HB1</b> <input type="checkbox"/>		Cartesian Robot: X-Y-Z 3-Axes Configuration Z-Axis Base Mount Type High-Precision Specification	
Type	XYB + Z-Axis Base Mount Type	Stroke	X-axis: 300-1000mm Y-axis: 200-700mm Z-axis: 100-500mm
Load capacity	14kg ~ 3kg		
Model specification items	Series	Type	Encoder type
(Example)	ICSA3 (ICSPA3)	-BE1HB1M-	A
			- 70AQL - 40AQL - 30BL - T1 - 5L - SC - SC

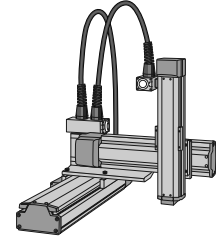

\* Refer to page 51 for the details of model specification items.

**Models/Specifications** \* [ ] is for the high-precision specification.

Encoder Type	XY-axis configuration direction (*1)	Z-axis type (*2)	Model
Absolute	1	H	ICSA3 [ICSPA3] -BE1HB1H-A- <input type="checkbox"/> - <input type="checkbox"/> - <input type="checkbox"/> -B-T1- <input type="checkbox"/> - <input type="checkbox"/>
		M	ICSA3 [ICSPA3] -BE1HB1M-A- <input type="checkbox"/> - <input type="checkbox"/> - <input type="checkbox"/> -B-T1- <input type="checkbox"/> - <input type="checkbox"/>
		L	ICSA3 [ICSPA3] -BE1HB1L-A- <input type="checkbox"/> - <input type="checkbox"/> - <input type="checkbox"/> -B-T1- <input type="checkbox"/> - <input type="checkbox"/>
	2	H	ICSA3 [ICSPA3] -BE2HB1H-A- <input type="checkbox"/> - <input type="checkbox"/> - <input type="checkbox"/> -B-T1- <input type="checkbox"/> - <input type="checkbox"/>
		M	ICSA3 [ICSPA3] -BE2HB1M-A- <input type="checkbox"/> - <input type="checkbox"/> - <input type="checkbox"/> -B-T1- <input type="checkbox"/> - <input type="checkbox"/>
		L	ICSA3 [ICSPA3] -BE2HB1L-A- <input type="checkbox"/> - <input type="checkbox"/> - <input type="checkbox"/> -B-T1- <input type="checkbox"/> - <input type="checkbox"/>
	3	H	ICSA3 [ICSPA3] -BE3HB1H-A- <input type="checkbox"/> - <input type="checkbox"/> - <input type="checkbox"/> -B-T1- <input type="checkbox"/> - <input type="checkbox"/>
		M	ICSA3 [ICSPA3] -BE3HB1M-A- <input type="checkbox"/> - <input type="checkbox"/> - <input type="checkbox"/> -B-T1- <input type="checkbox"/> - <input type="checkbox"/>
		L	ICSA3 [ICSPA3] -BE3HB1L-A- <input type="checkbox"/> - <input type="checkbox"/> - <input type="checkbox"/> -B-T1- <input type="checkbox"/> - <input type="checkbox"/>
	4	H	ICSA3 [ICSPA3] -BE4HB1H-A- <input type="checkbox"/> - <input type="checkbox"/> - <input type="checkbox"/> -B-T1- <input type="checkbox"/> - <input type="checkbox"/>
		M	ICSA3 [ICSPA3] -BE4HB1M-A- <input type="checkbox"/> - <input type="checkbox"/> - <input type="checkbox"/> -B-T1- <input type="checkbox"/> - <input type="checkbox"/>
		L	ICSA3 [ICSPA3] -BE4HB1L-A- <input type="checkbox"/> - <input type="checkbox"/> - <input type="checkbox"/> -B-T1- <input type="checkbox"/> - <input type="checkbox"/>
Incremental	1	H	ICSA3 [ICSPA3] -BE1HB1H-I- <input type="checkbox"/> - <input type="checkbox"/> - <input type="checkbox"/> -B-T1- <input type="checkbox"/> - <input type="checkbox"/>
		M	ICSA3 [ICSPA3] -BE1HB1M-I- <input type="checkbox"/> - <input type="checkbox"/> - <input type="checkbox"/> -B-T1- <input type="checkbox"/> - <input type="checkbox"/>
		L	ICSA3 [ICSPA3] -BE1HB1L-I- <input type="checkbox"/> - <input type="checkbox"/> - <input type="checkbox"/> -B-T1- <input type="checkbox"/> - <input type="checkbox"/>
	2	H	ICSA3 [ICSPA3] -BE2HB1H-I- <input type="checkbox"/> - <input type="checkbox"/> - <input type="checkbox"/> -B-T1- <input type="checkbox"/> - <input type="checkbox"/>
		M	ICSA3 [ICSPA3] -BE2HB1M-I- <input type="checkbox"/> - <input type="checkbox"/> - <input type="checkbox"/> -B-T1- <input type="checkbox"/> - <input type="checkbox"/>
		L	ICSA3 [ICSPA3] -BE2HB1L-I- <input type="checkbox"/> - <input type="checkbox"/> - <input type="checkbox"/> -B-T1- <input type="checkbox"/> - <input type="checkbox"/>
	3	H	ICSA3 [ICSPA3] -BE3HB1H-I- <input type="checkbox"/> - <input type="checkbox"/> - <input type="checkbox"/> -B-T1- <input type="checkbox"/> - <input type="checkbox"/>
		M	ICSA3 [ICSPA3] -BE3HB1M-I- <input type="checkbox"/> - <input type="checkbox"/> - <input type="checkbox"/> -B-T1- <input type="checkbox"/> - <input type="checkbox"/>
		L	ICSA3 [ICSPA3] -BE3HB1L-I- <input type="checkbox"/> - <input type="checkbox"/> - <input type="checkbox"/> -B-T1- <input type="checkbox"/> - <input type="checkbox"/>
	4	H	ICSA3 [ICSPA3] -BE4HB1H-I- <input type="checkbox"/> - <input type="checkbox"/> - <input type="checkbox"/> -B-T1- <input type="checkbox"/> - <input type="checkbox"/>
		M	ICSA3 [ICSPA3] -BE4HB1M-I- <input type="checkbox"/> - <input type="checkbox"/> - <input type="checkbox"/> -B-T1- <input type="checkbox"/> - <input type="checkbox"/>
		L	ICSA3 [ICSPA3] -BE4HB1L-I- <input type="checkbox"/> - <input type="checkbox"/> - <input type="checkbox"/> -B-T1- <input type="checkbox"/> - <input type="checkbox"/>

\*1: Refer to the figure below for XY-axis configuration direction.  
\*2: The load capacity and the maximum speed may vary depending on the type of Z-axis.  
Note: T1 in the above models will be T2 when operated with XSEL-P/G type.

**Explanation of Model Code**

Number	Contents	Specification
①	X-axis stroke (Note 1)	30 : 300mm ~ 100 : 1000mm
②	Y-axis stroke (Note 1)	20 : 200mm ~ 70 : 700mm
③	Z-axis stroke (Note 1)	10 : 100mm ~ 50 : 500mm
④	Cable length (Note 2)	3L : 3m 5L : 5m
⑤	Y-axis/ Z-axis cable management	SC-SC : Self-standing cable CT-CT : Cable track

\* The above explains the Models/Specifications chart to the left.

**Options**

Please add the option codes at the end of each stroke of the axis.  
When adding multiple options, put together in alphabetic order.

Name	Code	Page
AQ seal	AQ	→P13
Brake	B	→P13
Creep sensor	C	→P13
Home limit switch	L	→P14
Reversed-home specification	NM	→P14
Guide with ball-retaining mechanism	RT	→P14

**Configuration Direction**

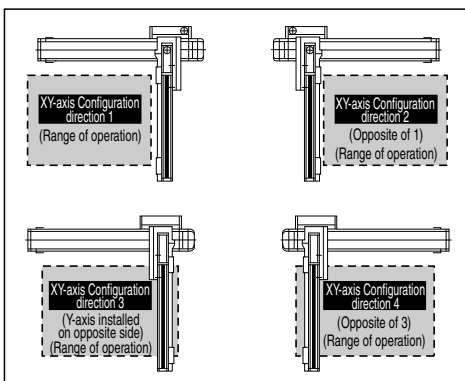

**Common Specifications** \* [ ] is for the high-precision specification.

Drive system	Ball screw, rolled C10 [equivalent to rolled C5]
Positioning repeatability	±0.02mm [±0.01mm]
Backlash	0.05mm or less [0.02mm or less]
Guide	Integrated with base
Base	Material: Aluminum with white alumite treatment
X-axis motor output / lead	400W / 20mm
Y-axis motor output / lead	200W / 20mm
Z-axis motor output / lead	60W / 16mm (H), 8mm (M), 4mm (L)

**Applicable Controller Specifications**

Refer to page 65 for System Configuration.

**Axis Configuration** \* [ ] is for the high-precision specification.

Axis Type	Model	Page
X-axis	ISA[ISPA]-LXM- <input type="checkbox"/> -400-20-(Stroke)-T1	→P26
Y-axis	ISA[ISPA]-MYM- <input type="checkbox"/> -200-20-(Stroke)-T1	→P22
Z-axis	ISA[ISPA]-SXM- <input type="checkbox"/> -60-16/8/4-(Stroke)-T1-B	→P15

\*In the above model name,  indicates encoder type A (absolute) or I (incremental).

**Caution**

(Note 1) The stroke in the model is specified in cm (centimeters).  
 (Note 2) The cable length measures from the X-axis connector box to the controller. The standard lengths are 3m and 5m, but other lengths can also be specified in meters. The maximum length is 20m.  
 (Note 3) The rated acceleration is 0.3G. Increasing the acceleration will result in lower load capacity.  
 (Note 4) Please note that a longer stroke will result in a lower maximum speed.

\* For other points to note, please refer to page 49.

ICSA3 [ICSPA3] - BE□HB1□

Single-Axis Robots

Cartesian Robots

Controllers

**Load Capacity (kg) (Note3)**

■ BE□HB1H

		Y-axis stroke					
		200	300	400	500	600	700
Z-axis stroke	100	3.0					
	200	3.0					
	300	3.0					
	400	3.0					
	500	3.0					

■ BE□HB1M

		Y-axis stroke					
		200	300	400	500	600	700
Z-axis stroke	100	6.0					
	200	6.0					
	300	6.0					
	400	6.0					
	500	6.0					

■ BE□HB1L

		Y-axis stroke					
		200	300	400	500	600	700
Z-axis stroke	100	14.0					
	200	14.0					13.5
	300	14.0					12.9
	300	14.0					12.3
	500	14.0					

**Maximum Speed by Stroke (mm/sec) (Note4)**

■ BE□HB1H

		Stroke										
		100	200	300	400	500	600	700	800	900	1000	
X-axis	-	-	1000						830	690	-	-
Y-axis	-	1000						-	-	-	-	-
Z-axis	800		-	-	-	-	-	-	-	-	-	

■ BE□HB1M

		Stroke										
		100	200	300	400	500	600	700	800	900	1000	
X-axis	-	-	1000						830	690	-	-
Y-axis	-	1000						-	-	-	-	
Z-axis	400		-	-	-	-	-	-	-	-	-	

■ BE□HB1L

		Stroke										
		100	200	300	400	500	600	700	800	900	1000	
X-axis	-	-	1000						830	690	-	-
Y-axis	-	1000						-	-	-	-	
Z-axis	200		-	-	-	-	-	-	-	-	-	

**Dimensions**

\* The dimension below is for XY-axis Configuration direction 1.

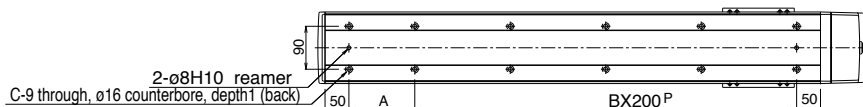
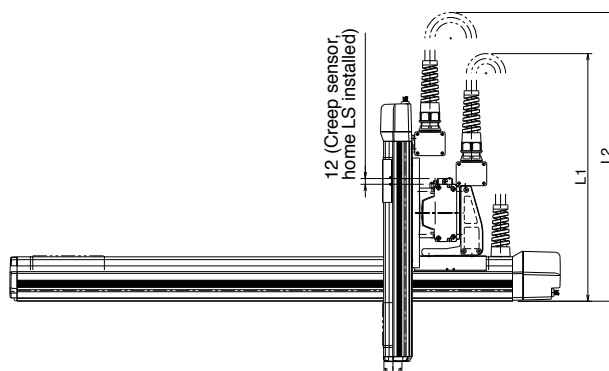
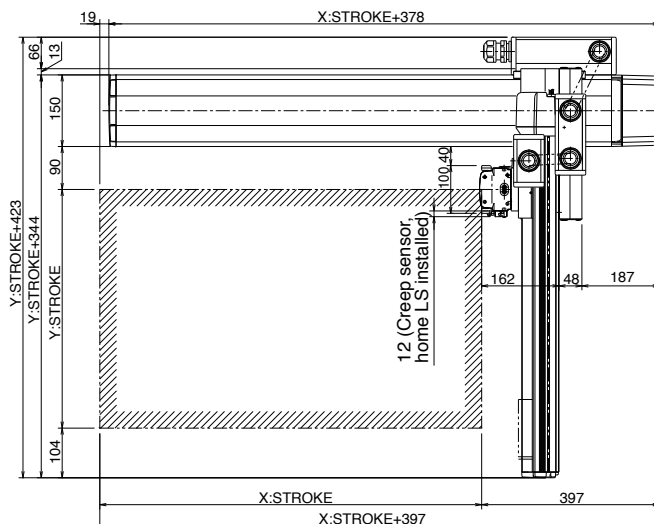
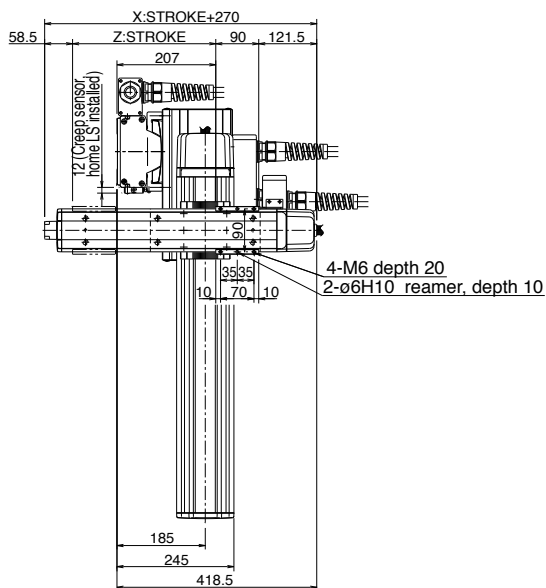

\* The configuration position in the figure is home position. To change the home position, indicate NM in the option. Note that changing the home direction will require the actuator to be returned to IAI for adjustment.

X stroke	300	400	500	600	700	800	900	1000
L1	(600)	(650)	(700)	(750)	(800)	(850)	(900)	(950)
A	238	138	238	138	238	138	238	138
B	1	2	2	3	3	4	4	5
C	6	8	8	10	10	12	12	14

Y stroke	200	300	400	500	600	700
L2	(690)	(740)	(790)	(840)	(890)	(940)

<b>ICSA3-BE HB2</b>		Cartesian Robot: X-Y-Z 3-Axes Configuration Z-Axis Base Mount Type	
<b>ICSPA3-BE HB2</b>		Cartesian Robot: X-Y-Z 3-Axes Configuration Z-Axis Base Mount Type High-Precision Specification	
Type	XYB + Z-Axis Base Mount Type	Stroke	X-axis: 300-1000mm Y-axis: 200-700mm Z-axis: 100-500mm
Load capacity	19kg ~ 3.5kg		
Model specification items	Series	Type	Encoder type
(Example)	ICSA3 (ICSPA3)	-BE1HB2M-	A
			- 70AQL - 40AQL - 30BL - T1 - 5L - SC - SC

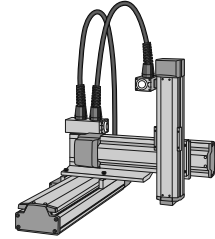

\* Refer to page 51 for the details of model specification items.

**Models/Specifications** \* [ ] is for the high-precision specification.

Encoder Type	XY-axis configuration direction (*1)	Z-axis type (*2)	Model
Absolute	1	H	ICSA3 [ICSPA3] -BE1HB2H-A-[1]-[2]-[3]-B-T1-[4]-[6]
		M	ICSA3 [ICSPA3] -BE1HB2M-A-[1]-[2]-[3]-B-T1-[4]-[6]
		L	ICSA3 [ICSPA3] -BE1HB2L-A-[1]-[2]-[3]-B-T1-[4]-[6]
	2	H	ICSA3 [ICSPA3] -BE2HB2H-A-[1]-[2]-[3]-B-T1-[4]-[6]
		M	ICSA3 [ICSPA3] -BE2HB2M-A-[1]-[2]-[3]-B-T1-[4]-[6]
		L	ICSA3 [ICSPA3] -BE2HB2L-A-[1]-[2]-[3]-B-T1-[4]-[6]
	3	H	ICSA3 [ICSPA3] -BE3HB2H-A-[1]-[2]-[3]-B-T1-[4]-[6]
		M	ICSA3 [ICSPA3] -BE3HB2M-A-[1]-[2]-[3]-B-T1-[4]-[6]
		L	ICSA3 [ICSPA3] -BE3HB2L-A-[1]-[2]-[3]-B-T1-[4]-[6]
	4	H	ICSA3 [ICSPA3] -BE4HB2H-A-[1]-[2]-[3]-B-T1-[4]-[6]
		M	ICSA3 [ICSPA3] -BE4HB2M-A-[1]-[2]-[3]-B-T1-[4]-[6]
		L	ICSA3 [ICSPA3] -BE4HB2L-A-[1]-[2]-[3]-B-T1-[4]-[6]
Incremental	1	H	ICSA3 [ICSPA3] -BE1HB2H-I-[1]-[2]-[3]-B-T1-[4]-[6]
		M	ICSA3 [ICSPA3] -BE1HB2M-I-[1]-[2]-[3]-B-T1-[4]-[6]
		L	ICSA3 [ICSPA3] -BE1HB2L-I-[1]-[2]-[3]-B-T1-[4]-[6]
	2	H	ICSA3 [ICSPA3] -BE2HB2H-I-[1]-[2]-[3]-B-T1-[4]-[6]
		M	ICSA3 [ICSPA3] -BE2HB2M-I-[1]-[2]-[3]-B-T1-[4]-[6]
		L	ICSA3 [ICSPA3] -BE2HB2L-I-[1]-[2]-[3]-B-T1-[4]-[6]
	3	H	ICSA3 [ICSPA3] -BE3HB2H-I-[1]-[2]-[3]-B-T1-[4]-[6]
		M	ICSA3 [ICSPA3] -BE3HB2M-I-[1]-[2]-[3]-B-T1-[4]-[6]
		L	ICSA3 [ICSPA3] -BE3HB2L-I-[1]-[2]-[3]-B-T1-[4]-[6]
	4	H	ICSA3 [ICSPA3] -BE4HB2H-I-[1]-[2]-[3]-B-T1-[4]-[6]
		M	ICSA3 [ICSPA3] -BE4HB2M-I-[1]-[2]-[3]-B-T1-[4]-[6]
		L	ICSA3 [ICSPA3] -BE4HB2L-I-[1]-[2]-[3]-B-T1-[4]-[6]

\*1: Refer to the figure below for XY-axis configuration direction.  
 \*2: The load capacity and the maximum speed may vary depending on the type of Z-axis.  
 Note: T1 in the above models will be T2 when operated with XSEL-P/Q type.

**Explanation of Model Code**

Number	Contents	Specification
①	X-axis stroke (Note 1)	30 : 300mm ~ 100 : 1000mm
②	Y-axis stroke (Note 1)	20 : 200mm ~ 70 : 700mm
③	Z-axis stroke (Note 1)	10 : 100mm ~ 50 : 500mm
④	Cable length (Note 2)	3L : 3m 5L : 5m
⑤	Y-axis/ Z-axis cable management	SC-SC : Self-standing cable CT-CT : Cable track

\* The above explains the Models/Specifications chart to the left.

**Options**

Please add the option codes at the end of each stroke of the axis.  
 When adding multiple options, put together in alphabetic order.

Name	Code	Page
AQ seal	AQ	→P13
Brake	B	→P13
Creep sensor	C	→P13
Home limit switch	L	→P14
Reversed-home specification	NM	→P14
Guide with ball-retaining mechanism	RT	→P14

**Configuration Direction**

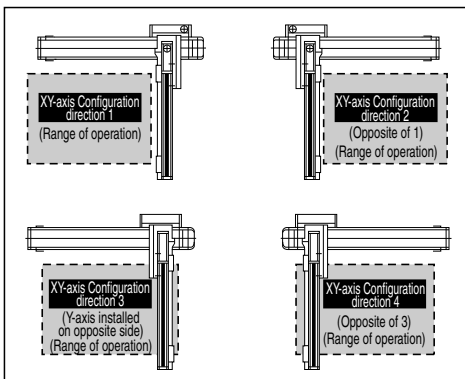

**Common Specifications** \* [ ] is for the high-precision specification.

Drive system	Ball screw, rolled C10 [equivalent to rolled C5]
Positioning repeatability	±0.02mm [±0.01mm]
Backlash	0.05mm or less [0.02mm or less]
Guide	Integrated with base
Base	Material: Aluminum with white alumite treatment
X-axis motor output / lead	400W / 20mm
Y-axis motor output / lead	200W / 20mm
Z-axis motor output / lead	100W / 20mm (H), 10mm (M), 5mm (L)

**Applicable Controller Specifications**

Refer to page 65 for System Configuration.

**Axis Configuration** \* [ ] is for the high-precision specification.

Axis Type	Model	Page
X-axis	ISA[ISPA]-LXM-□-400-20-(Stroke)-T1	→P26
Y-axis	ISA[ISPA]-MYM-□-200-20-(Stroke)-T1	→P22
Z-axis	ISA[ISPA]-MXM-□-100-20/10/5-(Stroke)-T1-B	→P18

\*In the above model name, □ indicates encoder type A (absolute) or I (incremental).

**Caution**

(Note 1) The stroke in the model is specified in cm (centimeters).  
 (Note 2) The cable length measures from the X-axis connector box to the controller. The standard lengths are 3m and 5m, but other lengths can also be specified in meters. The maximum length is 20m.  
 (Note 3) The rated acceleration is 0.3G. Increasing the acceleration will result in lower load capacity.  
 (Note 4) Please note that a longer stroke will result in a lower maximum speed.

\* For other points to note, please refer to page 49.



ICSA3 [ICSPA3] - BE□HB2□

Single-Axis Robots

Cartesian Robots

Controllers

**Load Capacity (kg) (Note3)**

■ BE□HB2H

		Y-axis stroke					
		200	300	400	500	600	700
Z-axis stroke	100	3.5					
	200	3.5					
	300	3.5					
	400	3.5					
	500	3.5					

■ BE□HB2M

		Y-axis stroke					
		200	300	400	500	600	700
Z-axis stroke	100	9.0					
	200	9.0					
	300	9.0				7.9	
	400	9.0				6.9	
	500	9.0				5.8	

■ BE□HB2L

		Y-axis stroke					
		200	300	400	500	600	700
Z-axis stroke	100	19.0	18.0	13.6	10.0		
	200	19.0	17.0	12.6	9.0		
	300	19.0	15.9	11.5	7.9		
	300	19.0	14.9	10.5	6.9		
	500	19.0	13.8	9.4	5.8		

**Maximum Speed by Stroke (mm/sec) (Note4)**

■ BE□HB2H

		Stroke									
		100	200	300	400	500	600	700	800	900	1000
X-axis	-	-	1000							830	690
Y-axis	-	1000							-	-	-
Z-axis	1000		-	-	-	-	-	-	-	-	

■ BE□HB2M

		Stroke									
		100	200	300	400	500	600	700	800	900	1000
X-axis	-	-	1000							830	690
Y-axis	-	1000							-	-	-
Z-axis	500		-	-	-	-	-	-	-	-	

■ BE□HB2L

		Stroke									
		100	200	300	400	500	600	700	800	900	1000
X-axis	-	-	1000							830	690
Y-axis	-	1000							-	-	-
Z-axis	250		-	-	-	-	-	-	-	-	

**Dimensions**

\* The dimension below is for XY-axis Configuration direction 1.

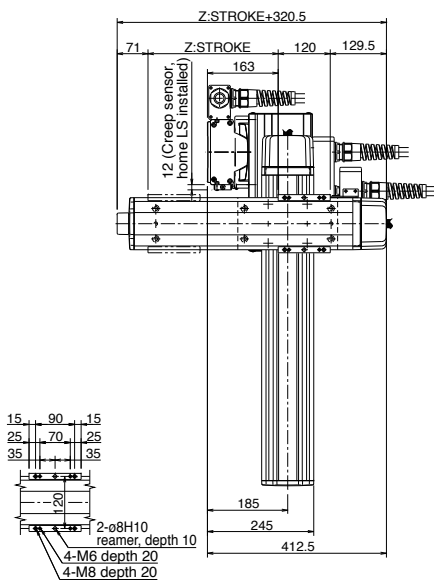

Detail View of Z-Axis slider

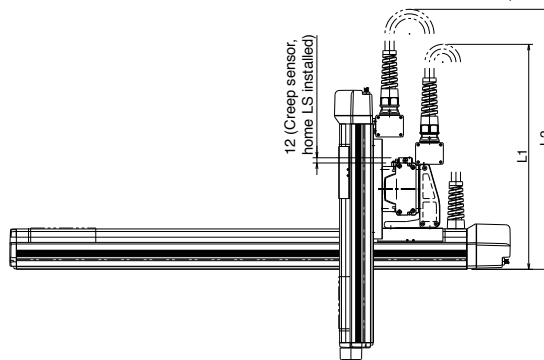
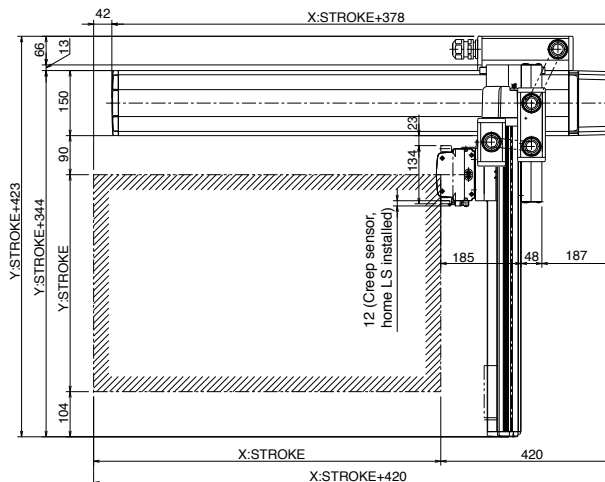

\* The configuration position in the figure is home position. To change the home position, indicate NM in the option. Note that changing the home direction will require the actuator to be returned to IAI for adjustment.

X stroke	300	400	500	600	700	800	900	1000
L1	(600)	(650)	(700)	(750)	(800)	(850)	(900)	(950)
A	238	138	238	138	238	138	238	138
B	1	2	2	3	3	4	4	5
C	6	8	8	10	10	12	12	14

Y stroke	200	300	400	500	600	700
L2	(690)	(740)	(790)	(840)	(890)	(940)

<b>ICSA3-BE</b> <input type="checkbox"/> <b>HB3</b> <input type="checkbox"/>		Cartesian Robot: X-Y-Z 3-Axes Configuration Z-Axis Base Mount Type
<b>ICSPA3-BE</b> <input type="checkbox"/> <b>HB3</b> <input type="checkbox"/>		Cartesian Robot: X-Y-Z 3-Axes Configuration Z-Axis Base Mount Type High-Precision Specification
Type	XYB + Z-Axis Base Mount Type	Stroke X-axis: 300-1000mm Y-axis: 200-700mm Z-axis: 100-500mm
		Load capacity 19kg ~ 5.8kg
Model specification items	Series	Type Encoder type X-axis stroke + options Y-axis stroke + options Z-axis stroke + options Applicable controller Cable length Cable management
(Example)	ICSA3 (ICSPA3)	- BE1HB3M - A - 70AQL - 40AQL - 30BL - T1 - 5L - SC - SC

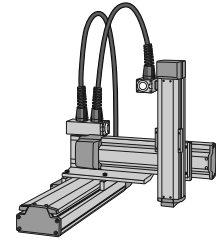

\* Refer to page 51 for the details of model specification items.

**Models/Specifications**

\* [ ] is for the high-precision specification.

Encoder Type	XY-axis configuration direction (*1)	Z-axis type (*2)	Model
Absolute	1	H	ICSA3 [ICSPA3] -BE1HB3H-A- [1] - [2] - [3] -B-T1- [4] - [6]
		M	ICSA3 [ICSPA3] -BE1HB3M-A- [1] - [2] - [3] -B-T1- [4] - [6]
	2	H	ICSA3 [ICSPA3] -BE2HB3H-A- [1] - [2] - [3] -B-T1- [4] - [6]
		M	ICSA3 [ICSPA3] -BE2HB3M-A- [1] - [2] - [3] -B-T1- [4] - [6]
	3	H	ICSA3 [ICSPA3] -BE3HB3H-A- [1] - [2] - [3] -B-T1- [4] - [6]
		M	ICSA3 [ICSPA3] -BE3HB3M-A- [1] - [2] - [3] -B-T1- [4] - [6]
4	H	ICSA3 [ICSPA3] -BE4HB3H-A- [1] - [2] - [3] -B-T1- [4] - [6]	
	M	ICSA3 [ICSPA3] -BE4HB3M-A- [1] - [2] - [3] -B-T1- [4] - [6]	
Incremental	1	H	ICSA3 [ICSPA3] -BE1HB3H-I- [1] - [2] - [3] -B-T1- [4] - [6]
		M	ICSA3 [ICSPA3] -BE1HB3M-I- [1] - [2] - [3] -B-T1- [4] - [6]
	2	H	ICSA3 [ICSPA3] -BE2HB3H-I- [1] - [2] - [3] -B-T1- [4] - [6]
		M	ICSA3 [ICSPA3] -BE2HB3M-I- [1] - [2] - [3] -B-T1- [4] - [6]
	3	H	ICSA3 [ICSPA3] -BE3HB3H-I- [1] - [2] - [3] -B-T1- [4] - [6]
		M	ICSA3 [ICSPA3] -BE3HB3M-I- [1] - [2] - [3] -B-T1- [4] - [6]
	4	H	ICSA3 [ICSPA3] -BE4HB3H-I- [1] - [2] - [3] -B-T1- [4] - [6]
		M	ICSA3 [ICSPA3] -BE4HB3M-I- [1] - [2] - [3] -B-T1- [4] - [6]

\*1: Refer to the figure below for XY-axis configuration direction.  
\*2: The load capacity and the maximum speed may vary depending on the type of Z-axis.  
Note: T1 in the above models will be T2 when operated with XSEL-P/Q type.

**Explanation of Model Code**

Number	Contents	Specification
[1]	X-axis stroke (Note 1)	30 : 300mm ~ 100 : 1000mm
[2]	Y-axis stroke (Note 1)	20 : 200mm ~ 70 : 700mm
[3]	Z-axis stroke (Note 1)	10 : 100mm ~ 50 : 500mm
[4]	Cable length (Note 2)	3L : 3m 5L : 5m
[6]	Y-axis/ Z-axis cable management	SC-SC : Self-standing cable CT-CT : Cable track

\* The above explains the Models/Specifications chart to the left.

**Options**

Please add the option codes at the end of each stroke of the axis.  
When adding multiple options, put together in alphabetic order.

Name	Code	Page
AQ seal	AQ	→P13
Brake	B	→P13
Creep sensor	C	→P13
Home limit switch	L	→P14
Reversed-home specification	NM	→P14
Guide with ball-retaining mechanism	RT	→P14

**Configuration Direction**

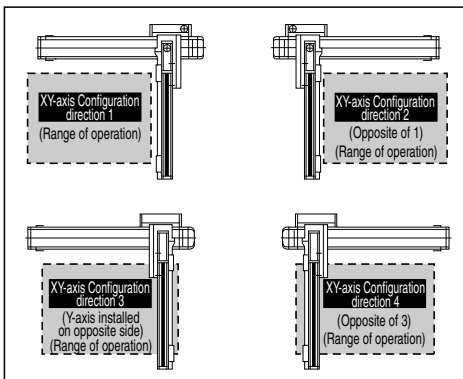

**Common Specifications**

\* [ ] is for the high-precision specification.

Drive system	Ball screw, rolled C10 [equivalent to rolled C5]
Positioning repeatability	±0.02mm [±0.01mm]
Backlash	0.05mm or less [0.02mm or less]
Guide	Integrated with base
Base	Material: Aluminum with white alumite treatment
X-axis motor output / lead	400W / 20mm
Y-axis motor output / lead	200W / 20mm
Z-axis motor output / lead	200W / 20mm (H), 10mm (M)

**Applicable Controller Specifications**

Refer to page 65 for System Configuration.

**Axis Configuration**

\* [ ] is for the high-precision specification.

Axis Type	Model	Page
X-axis	ISA[ISPA]-LXM-□-400-20-(Stroke)-T1	→P26
Y-axis	ISA[ISPA]-MYM-□-200-20-(Stroke)-T1	→P22
Z-axis	ISA[ISPA]-MXM-□-200-20/10-(Stroke)-T1-B	→P19

\*In the above model name, □ indicates encoder type A (absolute) or I (incremental).

**Caution**

(Note 1) The stroke in the model is specified in cm (centimeters).  
 (Note 2) The cable length measures from the X-axis connector box to the controller. The standard lengths are 3m and 5m, but other lengths can also be specified in meters. The maximum length is 20m.  
 (Note 3) The rated acceleration is 0.3G. Increasing the acceleration will result in lower load capacity.  
 (Note 4) Please note that a longer stroke will result in a lower maximum speed.

\* For other points to note, please refer to page 49.

ICSA3 [ICSPA3] - BE□HB3□

**Load Capacity (kg) (Note3)**

**BE□HB3H**

		Y-axis stroke					
		200	300	400	500	600	700
Z-axis stroke	100	9.0					
	200	9.0					
	300	9.0				7.9	
	400	9.0				6.9	
	500	9.0				5.8	

**BE□HB3M**

		Y-axis stroke					
		200	300	400	500	600	700
Z-axis stroke	100	19.0		18.0	13.6	10.0	
	200	19.0		17.0	12.6	9.0	
	300	19.0		15.9	11.5	7.9	
	400	19.0		14.9	10.5	6.9	
	500	19.0		13.8	9.4	5.8	

**Maximum Speed by Stroke (mm/sec) (Note4)**

**BE□HB3H**

	Stroke										
	100	200	300	400	500	600	700	800	900	1000	
X-axis	-	-	1000					-	-	830	690
Y-axis	-	1000							-	-	-
Z-axis	1000			-	-	-	-	-	-	-	

**BE□HB3M**

	Stroke										
	100	200	300	400	500	600	700	800	900	1000	
X-axis	-	-	1000					-	-	830	690
Y-axis	-	1000							-	-	-
Z-axis	500			-	-	-	-	-	-	-	

**Dimensions**

\* The dimension below is for XY-axis Configuration direction 1.

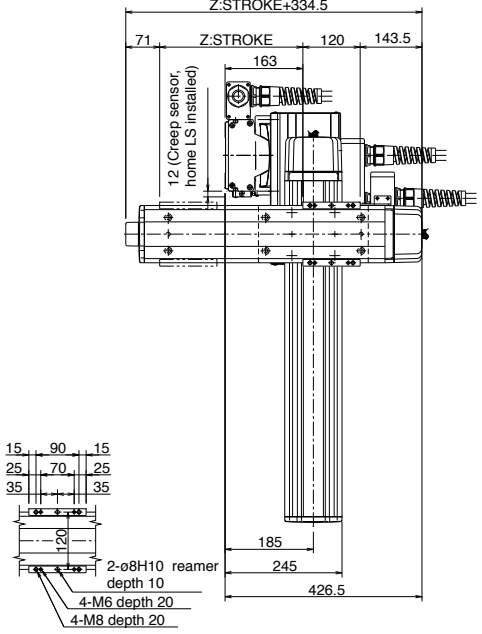

Detail View of Z-Axis slider

\* The configuration position in the figure is home position. To change the home position, indicate NM in the option. Note that changing the home direction will require the actuator to be returned to IAI for adjustment.

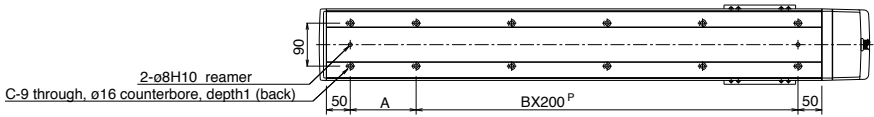
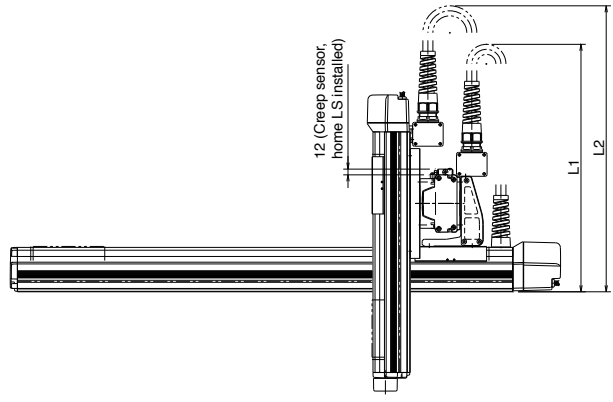
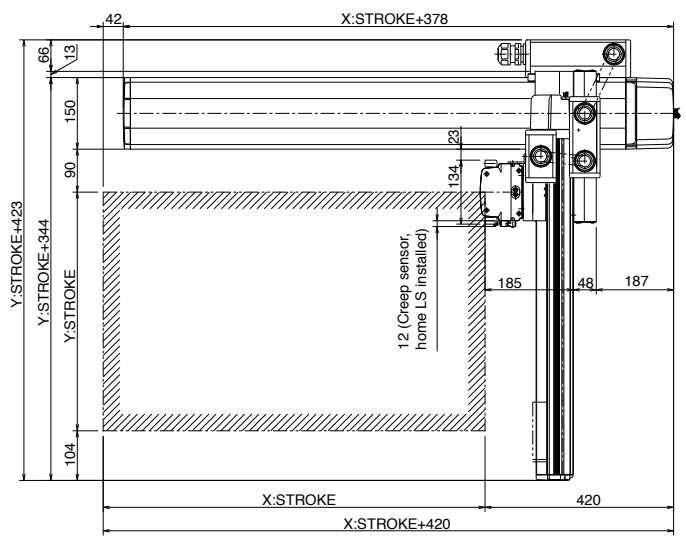

X stroke	300	400	500	600	700	800	900	1000
L1	(600)	(650)	(700)	(750)	(800)	(850)	(900)	(950)
A	238	138	238	138	238	138	238	138
B	1	2	2	3	3	4	4	5
C	6	8	8	10	10	12	12	14

Y stroke	200	300	400	500	600	700
L2	(690)	(740)	(790)	(840)	(890)	(940)

<b>ICSA3-BE MB2</b>		Cartesian Robot: X-Y-Z 3-Axes Configuration Z-Axis Base Mount Type	
<b>ICSPA3-BE MB2</b>		Cartesian Robot: X-Y-Z 3-Axes Configuration Z-Axis Base Mount Type High-Precision Specification	
Type	XYB + Z-Axis Base Mount Type	Stroke	X-axis: 300-1000mm Y-axis: 200-700mm Z-axis: 100-500mm
		Load capacity	19kg ~ 3.5kg
Model specification items	Series	Type	Encoder type
(Example)	ICSA3 (ICSPA3)	BE1MB2M-	A
			- 70AQL - 40AQL - 30BL - T1 - 5L - SC - SC

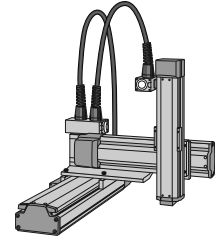

\* Refer to page 51 for the details of model specification items.

**Models/Specifications**

\* [ ] is for the high-precision specification.

Encoder Type	XY-axis configuration direction (*1)	Z-axis type (*2)	Model
Absolute	1	H	ICSA3 [ICSPA3] -BE1MB2H-A-[0]-[2]-[3]-B-T1-[4]-[6]
		M	ICSA3 [ICSPA3] -BE1MB2M-A-[0]-[2]-[3]-B-T1-[4]-[6]
		L	ICSA3 [ICSPA3] -BE1MB2L-A-[0]-[2]-[3]-B-T1-[4]-[6]
	2	H	ICSA3 [ICSPA3] -BE2MB2H-A-[0]-[2]-[3]-B-T1-[4]-[6]
		M	ICSA3 [ICSPA3] -BE2MB2M-A-[0]-[2]-[3]-B-T1-[4]-[6]
		L	ICSA3 [ICSPA3] -BE2MB2L-A-[0]-[2]-[3]-B-T1-[4]-[6]
	3	H	ICSA3 [ICSPA3] -BE3MB2H-A-[0]-[2]-[3]-B-T1-[4]-[6]
		M	ICSA3 [ICSPA3] -BE3MB2M-A-[0]-[2]-[3]-B-T1-[4]-[6]
		L	ICSA3 [ICSPA3] -BE3MB2L-A-[0]-[2]-[3]-B-T1-[4]-[6]
	4	H	ICSA3 [ICSPA3] -BE4MB2H-A-[0]-[2]-[3]-B-T1-[4]-[6]
		M	ICSA3 [ICSPA3] -BE4MB2M-A-[0]-[2]-[3]-B-T1-[4]-[6]
		L	ICSA3 [ICSPA3] -BE4MB2L-A-[0]-[2]-[3]-B-T1-[4]-[6]
Incremental	1	H	ICSA3 [ICSPA3] -BE1MB2H-I-[0]-[2]-[3]-B-T1-[4]-[6]
		M	ICSA3 [ICSPA3] -BE1MB2M-I-[0]-[2]-[3]-B-T1-[4]-[6]
		L	ICSA3 [ICSPA3] -BE1MB2L-I-[0]-[2]-[3]-B-T1-[4]-[6]
	2	H	ICSA3 [ICSPA3] -BE2MB2H-I-[0]-[2]-[3]-B-T1-[4]-[6]
		M	ICSA3 [ICSPA3] -BE2MB2M-I-[0]-[2]-[3]-B-T1-[4]-[6]
		L	ICSA3 [ICSPA3] -BE2MB2L-I-[0]-[2]-[3]-B-T1-[4]-[6]
	3	H	ICSA3 [ICSPA3] -BE3MB2H-I-[0]-[2]-[3]-B-T1-[4]-[6]
		M	ICSA3 [ICSPA3] -BE3MB2M-I-[0]-[2]-[3]-B-T1-[4]-[6]
		L	ICSA3 [ICSPA3] -BE3MB2L-I-[0]-[2]-[3]-B-T1-[4]-[6]
	4	H	ICSA3 [ICSPA3] -BE4MB2H-I-[0]-[2]-[3]-B-T1-[4]-[6]
		M	ICSA3 [ICSPA3] -BE4MB2M-I-[0]-[2]-[3]-B-T1-[4]-[6]
		L	ICSA3 [ICSPA3] -BE4MB2L-I-[0]-[2]-[3]-B-T1-[4]-[6]

\*1: Refer to the figure below for XY-axis configuration direction.  
 \*2: The load capacity and the maximum speed may vary depending on the type of Z-axis.  
 Note: T1 in the above models will be T2 when operated with XSEL-P/Q type.

**Explanation of Model Code**

Number	Contents	Specification
①	X-axis stroke (Note 1)	30 : 300mm ~ 100 : 1000mm
②	Y-axis stroke (Note 1)	20 : 200mm ~ 70 : 700mm
③	Z-axis stroke (Note 1)	10 : 100mm ~ 50 : 500mm
④	Cable length (Note 2)	3L : 3m 5L : 5m
⑤	Y-axis/ Z-axis cable management	SC-SC : Self-standing cable CT-CT : Cable track

\* The above explains the Models/Specifications chart to the left.

**Options**

Please add the option codes at the end of each stroke of the axis.  
 When adding multiple options, put together in alphabetic order.

Name	Code	Page
AQ seal	AQ	→P13
Brake	B	→P13
Creep sensor	C	→P13
Home limit switch	L	→P14
Reversed-home specification	NM	→P14
Guide with ball-retaining mechanism	RT	→P14

**Configuration Direction**

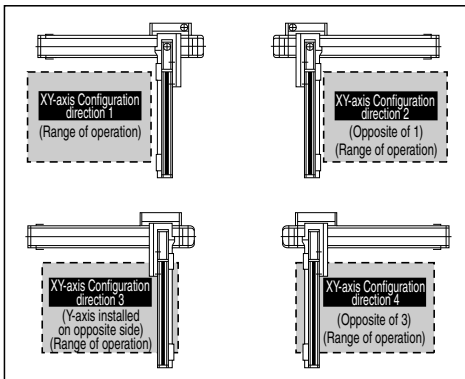

**Common Specifications**

\* [ ] is for the high-precision specification.

Drive system	Ball screw, rolled C10 [equivalent to rolled C5]
Positioning repeatability	±0.02mm [±0.01mm]
Backlash	0.05mm or less [0.02mm or less]
Guide	Integrated with base
Base	Material: Aluminum with white alumite treatment
X-axis motor output / lead	200W / 10mm
Y-axis motor output / lead	200W / 10mm
Z-axis motor output / lead	100W / 20mm (H), 10mm (M), 5mm (L)

**Applicable Controller Specifications**

Refer to page 65 for System Configuration.

**Axis Configuration**

\* [ ] is for the high-precision specification.

Axis Type	Model	Page
X-axis	ISA[ISPA]-LXM-[ ]-200-10-(Stroke)-T1	→P25
Y-axis	ISA[ISPA]-MYM-[ ]-200-10-(Stroke)-T1	→P22
Z-axis	ISA[ISPA]-MXM-[ ]-100-20/10/5-(Stroke)-T1-B	→P18

\*In the above model name, [ ] indicates encoder type A (absolute) or I (incremental).

**Caution**

(Note 1) The stroke in the model is specified in cm (centimeters).  
 (Note 2) The cable length measures from the X-axis connector box to the controller. The standard lengths are 3m and 5m, but other lengths can also be specified in meters. The maximum length is 20m.  
 (Note 3) The rated acceleration is 0.3G. Increasing the acceleration will result in lower load capacity.  
 (Note 4) Please note that a longer stroke will result in a lower maximum speed.

\* For other points to note, please refer to page 49.

ICSA3 [ICSPA3] - BE□MB2□

Single-Axis Robots

Cartesian Robots

Controllers

Load Capacity (kg) (Note3)

BE□MB2H

		Y-axis stroke					
		200	300	400	500	600	700
Z-axis stroke	100	3.5					
	200	3.5					
	300	3.5					
	400	3.5					
	500	3.5					

BE□MB2M

		Y-axis stroke					
		200	300	400	500	600	700
Z-axis stroke	100	9.0					
	200	9.0					
	300	9.0				7.9	
	400	9.0				6.9	
	500	9.0				5.8	

BE□MB2L

		Y-axis stroke					
		200	300	400	500	600	700
Z-axis stroke	100	19.0	18.0	13.6	10.0		
	200	19.0	17.0	12.6	9.0		
	300	19.0	15.9	11.5	7.9		
	300	19.0	14.9	10.5	6.9		
	500	19.0	13.8	9.4	5.8		

Maximum Speed by Stroke (mm/sec) (Note4)

BE□MB2H

	Stroke										
	100	200	300	400	500	600	700	800	900	1000	
X-axis	-	-	500				470	385	320		
Y-axis	-	500				480	-	-	-		
Z-axis	1000			-	-	-	-	-			

BE□MB2M

	Stroke										
	100	200	300	400	500	600	700	800	900	1000	
X-axis	-	-	500				470	385	320		
Y-axis	-	500				480	-	-	-		
Z-axis	500			-	-	-	-	-			

BE□MB2L

	Stroke										
	100	200	300	400	500	600	700	800	900	1000	
X-axis	-	-	500				470	385	320		
Y-axis	-	500				480	-	-	-		
Z-axis	250			-	-	-	-	-			

Dimensions

\* The dimension below is for XY-axis Configuration direction 1.

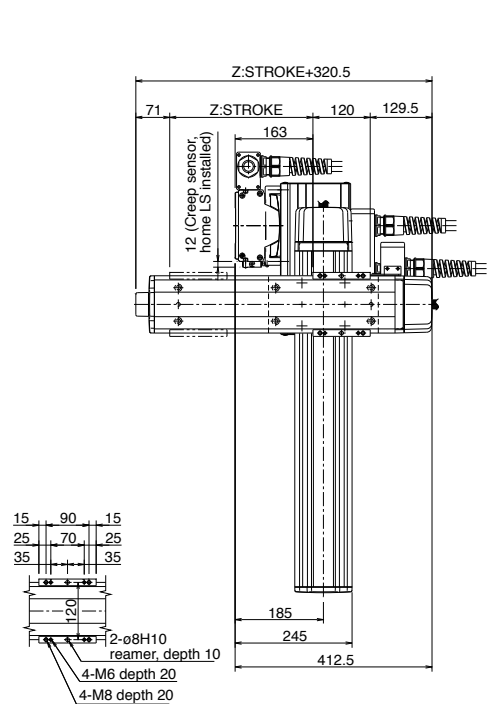

Detail View of Z-Axis slider

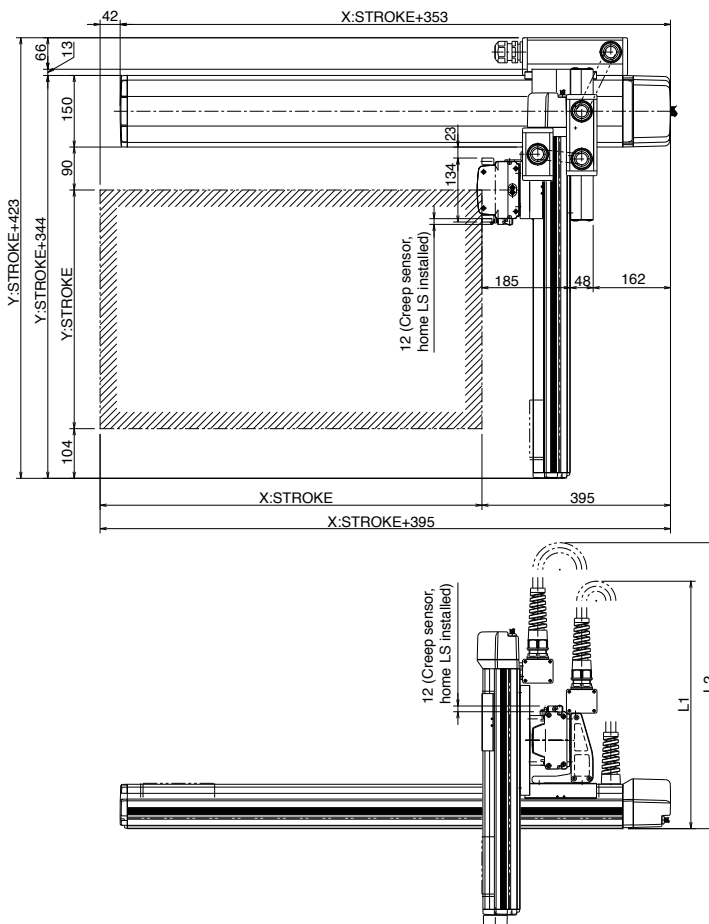

\* The configuration position in the figure is home position. To change the home position, indicate NM in the option. Note that changing the home direction will require the actuator to be returned to IAI for adjustment.

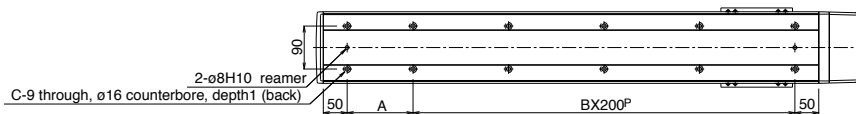

X stroke	300	400	500	600	700	800	900	1000
L1	(600)	(650)	(700)	(750)	(800)	(850)	(900)	(950)
A	238	138	238	138	238	138	238	138
B	1	2	2	3	3	4	4	5
C	6	8	8	10	10	12	12	14

Y stroke	200	300	400	500	600	700
L2	(690)	(740)	(790)	(840)	(890)	(940)

**ICSA3-BE MB3** Cartesian Robot: X-Y-Z 3-Axes Configuration  
Z-Axis Base Mount Type

**ICSPA3-BE MB3** Cartesian Robot: X-Y-Z 3-Axes Configuration  
Z-Axis Base Mount Type High-Precision Specification

Type XYB + Z-Axis Base Mount Type Stroke X-axis: 300-1000mm Y-axis: 200-700mm Z-axis: 100-500mm Load capacity 19kg ~ 5.8kg

Model specification items Series Type Encoder type X-axis stroke + options Y-axis stroke + options Z-axis stroke + options Applicable controller Cable length Cable management  
(Example) ICSA3 (ICSPA3) BE1MB3M-A A - 70AQL - 40AQL - 30BL - T1 - 5L - SC - SC

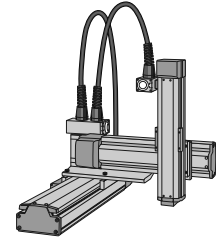

\* Refer to page 51 for the details of model specification items.

**Models/Specifications** \* [ ] is for the high-precision specification.

Encoder Type	XY-axis configuration direction (*1)	Z-axis type (*2)	Model
Absolute	1	H	ICSA3 [ICSPA3] -BE1MB3H-A-①-②-③-B-T1-④-⑤
		M	ICSA3 [ICSPA3] -BE1MB3M-A-①-②-③-B-T1-④-⑤
	2	H	ICSA3 [ICSPA3] -BE2MB3H-A-①-②-③-B-T1-④-⑤
		M	ICSA3 [ICSPA3] -BE2MB3M-A-①-②-③-B-T1-④-⑤
	3	H	ICSA3 [ICSPA3] -BE3MB3H-A-①-②-③-B-T1-④-⑤
		M	ICSA3 [ICSPA3] -BE3MB3M-A-①-②-③-B-T1-④-⑤
4	H	ICSA3 [ICSPA3] -BE4MB3H-A-①-②-③-B-T1-④-⑤	
	M	ICSA3 [ICSPA3] -BE4MB3M-A-①-②-③-B-T1-④-⑤	
Incremental	1	H	ICSA3 [ICSPA3] -BE1MB3H-I-①-②-③-B-T1-④-⑤
		M	ICSA3 [ICSPA3] -BE1MB3M-I-①-②-③-B-T1-④-⑤
	2	H	ICSA3 [ICSPA3] -BE2MB3H-I-①-②-③-B-T1-④-⑤
		M	ICSA3 [ICSPA3] -BE2MB3M-I-①-②-③-B-T1-④-⑤
	3	H	ICSA3 [ICSPA3] -BE3MB3H-I-①-②-③-B-T1-④-⑤
		M	ICSA3 [ICSPA3] -BE3MB3M-I-①-②-③-B-T1-④-⑤
	4	H	ICSA3 [ICSPA3] -BE4MB3H-I-①-②-③-B-T1-④-⑤
		M	ICSA3 [ICSPA3] -BE4MB3M-I-①-②-③-B-T1-④-⑤

\*1: Refer to the figure below for XY-axis configuration direction.  
\*2: The load capacity and the maximum speed may vary depending on the type of Z-axis.  
Note: T1 in the above models will be T2 when operated with XSEL-P/Q type.

**Explanation of Model Code**

Number	Contents	Specification
①	X-axis stroke (Note 1)	30 : 300mm ~ 100 : 1000mm
②	Y-axis stroke (Note 1)	20 : 200mm ~ 70 : 700mm
③	Z-axis stroke (Note 1)	10 : 100mm ~ 50 : 500mm
④	Cable length (Note 2)	3L : 3m 5L : 5m
⑤	Y-axis/ Z-axis cable management	SC-SC : Self-standing cable CT-CT : Cable track

\* The above explains the Models/Specifications chart to the left.

**Options**

Please add the option codes at the end of each stroke of the axis.  
When adding multiple options, put together in alphabetic order.

Name	Code	Page
AQ seal	AQ	→P13
Brake	B	→P13
Creep sensor	C	→P13
Home limit switch	L	→P14
Reversed-home specification	NM	→P14
Guide with ball-retaining mechanism	RT	→P14

**Configuration Direction**

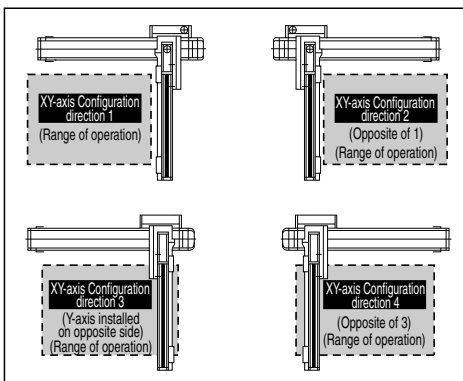

**Common Specifications** \* [ ] is for the high-precision specification.

Drive system	Ball screw, rolled C10 [equivalent to rolled C5]
Positioning repeatability	±0.02mm [±0.01mm]
Backlash	0.05mm or less [0.02mm or less]
Guide	Integrated with base
Base	Material: Aluminum with white alumite treatment
X-axis motor output / lead	200W / 10mm
Y-axis motor output / lead	200W / 10mm
Z-axis motor output / lead	200W / 20mm (H), 10mm (M)

**Applicable Controller Specifications**

Refer to page 65 for System Configuration.

**Axis Configuration** \* [ ] is for the high-precision specification.

Axis Type	Model	Page
X-axis	ISA[ISPA]-LXM-□-200-10-(Stroke)-T1	→P25
Y-axis	ISA[ISPA]-MYM-□-200-10-(Stroke)-T1	→P22
Z-axis	ISA[ISPA]-MXM-□-200-20/10-(Stroke)-T1-B	→P19

\*In the above model name, □ indicates encoder type A (absolute) or I (incremental).

**Caution**

(Note 1) The stroke in the model is specified in cm (centimeters).  
(Note 2) The cable length measures from the X-axis connector box to the controller. The standard lengths are 3m and 5m, but other lengths can also be specified in meters. The maximum length is 20m.  
(Note 3) The rated acceleration is 0.3G. Increasing the acceleration will result in lower load capacity.  
(Note 4) Please note that a longer stroke will result in a lower maximum speed.

\* For other points to note, please refer to page 49.

ICSA3 [ICSPA3] - BE□MB3□

Single-Axis Robots

Cartesian Robots

Controllers

**Load Capacity (kg) (Note3)**

**BE□MB3H**

		Y-axis stroke					
		200	300	400	500	600	700
Z-axis stroke	100	9.0					
	200	9.0					
	300	9.0				7.9	
	400	9.0				6.9	
	500	9.0				5.8	

**BE□MB3M**

		Y-axis stroke					
		200	300	400	500	600	700
Z-axis stroke	100	19.0		18.0	13.6	10.0	
	200	19.0		17.0	12.6	9.0	
	300	19.0		15.9	11.5	7.9	
	400	19.0		14.9	10.5	6.9	
	500	19.0		13.8	9.4	5.8	

**Maximum Speed by Stroke (mm/sec) (Note4)**

**BE□MB3H**

	Stroke										
	100	200	300	400	500	600	700	800	900	1000	
X-axis	-	-	500				470	385	320		
Y-axis	-	500				480	-	-	-		
Z-axis	1000		-	-	-	-	-	-			

**BE□MB3M**

	Stroke										
	100	200	300	400	500	600	700	800	900	1000	
X-axis	-	-	500				470	385	320		
Y-axis	-	500				480	-	-	-		
Z-axis	500		-	-	-	-	-	-			

**Dimensions**

\* The dimension below is for XY-axis Configuration direction 1.

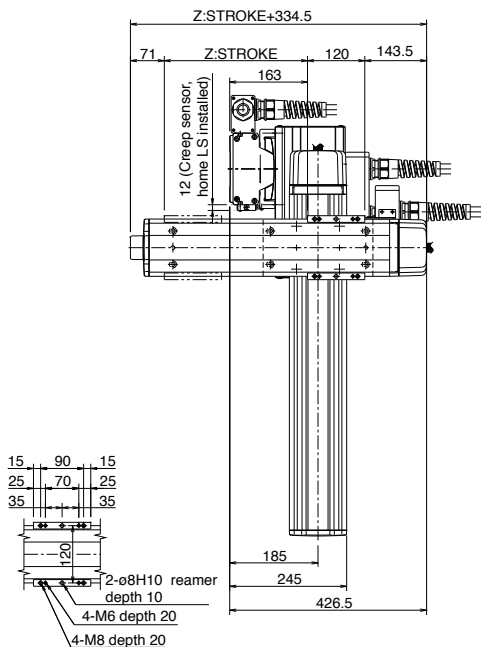

Detail View of Z-Axis slider

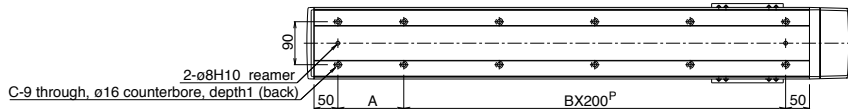
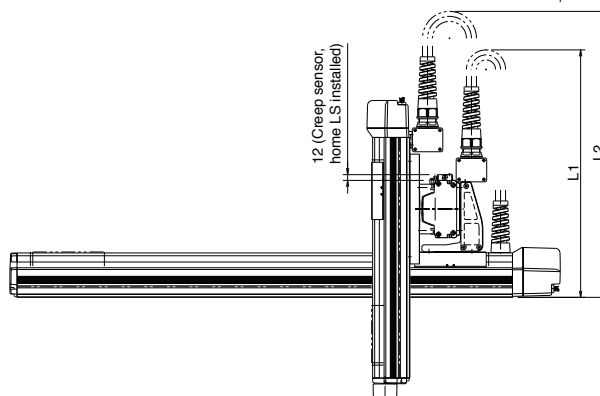
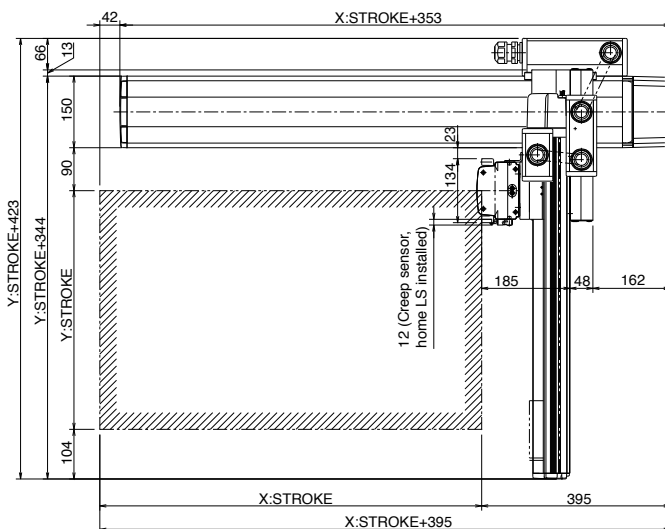

\* The configuration position in the figure is home position. To change the home position, indicate NM in the option. Note that changing the home direction will require the actuator to be returned to IAI for adjustment.

X stroke	300	400	500	600	700	800	900	1000
L1	(600)	(650)	(700)	(750)	(800)	(850)	(900)	(950)
A	238	138	238	138	238	138	238	138
B	1	2	2	3	3	4	4	5
C	6	8	8	10	10	12	12	14

Y stroke	200	300	400	500	600	700
L2	(690)	(740)	(790)	(840)	(890)	(940)

<b>ICSA3-BF</b> <input type="checkbox"/> <b>HB1</b> <input type="checkbox"/>		Cartesian Robot: X-Y-Z 3-Axes Configuration Z-Axis Base Mount Type	
<b>ICSPA3-BF</b> <input type="checkbox"/> <b>HB1</b> <input type="checkbox"/>		Cartesian Robot: X-Y-Z 3-Axes Configuration Z-Axis Base Mount Type High-Precision Specification	
Type	XYB + Z-Axis Base Mount Type	Stroke	X-axis: 1000-2500mm Y-axis: 200-700mm Z-axis: 100-500mm
Load capacity	14kg ~ 3kg		
Model specification items	Series	Type	Encoder type
(Example)	ICSA3 (ICSPA3)	-BF/1HB1M-	A
			- 100AQL - 40AQL - 30BL - T1 - 5L - CT - SC

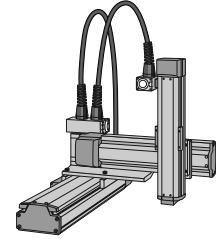

\* Refer to page 51 for the details of model specification items.

**Models/Specifications**

\* [ ] is for the high-precision specification.

Encoder Type	XY-axis configuration direction (*1)	Z-axis type (*2)	Model
Absolute	1	H	ICSA3 [ICSPA3] -BF1HB1H-A- <input type="checkbox"/> - <input type="checkbox"/> - <input type="checkbox"/> -B-T1- <input type="checkbox"/> - <input type="checkbox"/>
		M	ICSA3 [ICSPA3] -BF1HB1M-A- <input type="checkbox"/> - <input type="checkbox"/> - <input type="checkbox"/> -B-T1- <input type="checkbox"/> - <input type="checkbox"/>
		L	ICSA3 [ICSPA3] -BF1HB1L-A- <input type="checkbox"/> - <input type="checkbox"/> - <input type="checkbox"/> -B-T1- <input type="checkbox"/> - <input type="checkbox"/>
	2	H	ICSA3 [ICSPA3] -BF2HB1H-A- <input type="checkbox"/> - <input type="checkbox"/> - <input type="checkbox"/> -B-T1- <input type="checkbox"/> - <input type="checkbox"/>
		M	ICSA3 [ICSPA3] -BF2HB1M-A- <input type="checkbox"/> - <input type="checkbox"/> - <input type="checkbox"/> -B-T1- <input type="checkbox"/> - <input type="checkbox"/>
		L	ICSA3 [ICSPA3] -BF2HB1L-A- <input type="checkbox"/> - <input type="checkbox"/> - <input type="checkbox"/> -B-T1- <input type="checkbox"/> - <input type="checkbox"/>
	3	H	ICSA3 [ICSPA3] -BF3HB1H-A- <input type="checkbox"/> - <input type="checkbox"/> - <input type="checkbox"/> -B-T1- <input type="checkbox"/> - <input type="checkbox"/>
		M	ICSA3 [ICSPA3] -BF3HB1M-A- <input type="checkbox"/> - <input type="checkbox"/> - <input type="checkbox"/> -B-T1- <input type="checkbox"/> - <input type="checkbox"/>
		L	ICSA3 [ICSPA3] -BF3HB1L-A- <input type="checkbox"/> - <input type="checkbox"/> - <input type="checkbox"/> -B-T1- <input type="checkbox"/> - <input type="checkbox"/>
	4	H	ICSA3 [ICSPA3] -BF4HB1H-A- <input type="checkbox"/> - <input type="checkbox"/> - <input type="checkbox"/> -B-T1- <input type="checkbox"/> - <input type="checkbox"/>
		M	ICSA3 [ICSPA3] -BF4HB1M-A- <input type="checkbox"/> - <input type="checkbox"/> - <input type="checkbox"/> -B-T1- <input type="checkbox"/> - <input type="checkbox"/>
		L	ICSA3 [ICSPA3] -BF4HB1L-A- <input type="checkbox"/> - <input type="checkbox"/> - <input type="checkbox"/> -B-T1- <input type="checkbox"/> - <input type="checkbox"/>
Incremental	1	H	ICSA3 [ICSPA3] -BF1HB1H-I- <input type="checkbox"/> - <input type="checkbox"/> - <input type="checkbox"/> -B-T1- <input type="checkbox"/> - <input type="checkbox"/>
		M	ICSA3 [ICSPA3] -BF1HB1M-I- <input type="checkbox"/> - <input type="checkbox"/> - <input type="checkbox"/> -B-T1- <input type="checkbox"/> - <input type="checkbox"/>
		L	ICSA3 [ICSPA3] -BF1HB1L-I- <input type="checkbox"/> - <input type="checkbox"/> - <input type="checkbox"/> -B-T1- <input type="checkbox"/> - <input type="checkbox"/>
	2	H	ICSA3 [ICSPA3] -BF2HB1H-I- <input type="checkbox"/> - <input type="checkbox"/> - <input type="checkbox"/> -B-T1- <input type="checkbox"/> - <input type="checkbox"/>
		M	ICSA3 [ICSPA3] -BF2HB1M-I- <input type="checkbox"/> - <input type="checkbox"/> - <input type="checkbox"/> -B-T1- <input type="checkbox"/> - <input type="checkbox"/>
		L	ICSA3 [ICSPA3] -BF2HB1L-I- <input type="checkbox"/> - <input type="checkbox"/> - <input type="checkbox"/> -B-T1- <input type="checkbox"/> - <input type="checkbox"/>
	3	H	ICSA3 [ICSPA3] -BF3HB1H-I- <input type="checkbox"/> - <input type="checkbox"/> - <input type="checkbox"/> -B-T1- <input type="checkbox"/> - <input type="checkbox"/>
		M	ICSA3 [ICSPA3] -BF3HB1M-I- <input type="checkbox"/> - <input type="checkbox"/> - <input type="checkbox"/> -B-T1- <input type="checkbox"/> - <input type="checkbox"/>
		L	ICSA3 [ICSPA3] -BF3HB1L-I- <input type="checkbox"/> - <input type="checkbox"/> - <input type="checkbox"/> -B-T1- <input type="checkbox"/> - <input type="checkbox"/>
	4	H	ICSA3 [ICSPA3] -BF4HB1H-I- <input type="checkbox"/> - <input type="checkbox"/> - <input type="checkbox"/> -B-T1- <input type="checkbox"/> - <input type="checkbox"/>
		M	ICSA3 [ICSPA3] -BF4HB1M-I- <input type="checkbox"/> - <input type="checkbox"/> - <input type="checkbox"/> -B-T1- <input type="checkbox"/> - <input type="checkbox"/>
		L	ICSA3 [ICSPA3] -BF4HB1L-I- <input type="checkbox"/> - <input type="checkbox"/> - <input type="checkbox"/> -B-T1- <input type="checkbox"/> - <input type="checkbox"/>

\*1: Refer to the figure below for XY-axis configuration direction.  
\*2: The load capacity and the maximum speed may vary depending on the type of Z-axis.  
Note: T1 in the above models will be T2 when operated with XSEL-P/G type.

**Explanation of Model Code**

Number	Contents	Specification
①	X-axis stroke (Note 1)	100 : 1000mm ~ 250 : 2500mm
②	Y-axis stroke (Note 1)	20 : 200mm ~ 70 : 700mm
③	Z-axis stroke (Note 1)	10 : 100mm ~ 50 : 500mm
④	Cable length (Note 2)	3L : 3m 5L : 5m
⑤	Y-axis/ Z-axis cable management	CT-SC : Self-standing cable (*3) CT-CT : Cable track

\* The above explains the Models/Specifications chart to the left.  
\*3 Only cable track can be specified for the Y-axis cable management with model # BF□HB1□.

**Options**

Please add the option codes at the end of each stroke of the axis.  
When adding multiple options, put together in alphabetic order.

Name	Code	Page
AQ seal	AQ	→P13
Brake	B	→P13
Creep sensor	C	→P13
Home limit switch	L	→P14
Reversed-home specification	NM	→P14
Guide with ball-retaining mechanism	RT	→P14

**Configuration Direction**

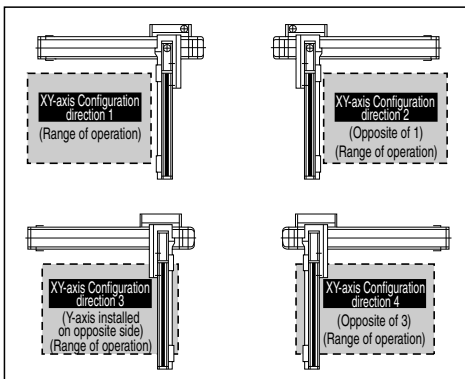

**Common Specifications**

\* [ ] is for the high-precision specification.

Drive system	Ball screw, rolled C10 [equivalent to rolled C5]
Positioning repeatability	±0.02mm [±0.01mm]
Backlash	0.05mm or less [0.02mm or less]
Guide	Integrated with base
Base	Material: Aluminum with white alumite treatment
X-axis motor output / lead	400W / 20mm
Y-axis motor output / lead	200W / 20mm
Z-axis motor output / lead	60W / 16mm (H), 8mm (M), 4mm (L)

**Applicable Controller Specifications**

Refer to page 65 for System Configuration.

**Axis Configuration**

\* [ ] is for the high-precision specification.

Axis Type	Model	Page
X-axis	ISA[ISPA]-LXXM-□-400-20-(Stroke)-T1	→P28
Y-axis	ISA[ISPA]-MYM-□-200-20-(Stroke)-T1	→P22
Z-axis	ISA[ISPA]-SXM-□-60-16/8/4-(Stroke)-T1-B	→P15

\*In the above model name, □ indicates encoder type A (absolute) or I (incremental).

**Caution**

(Note 1) The stroke in the model is specified in cm (centimeters).  
 (Note 2) The cable length measures from the X-axis connector box to the controller. The standard lengths are 3m and 5m, but other lengths can also be specified in meters. The maximum length is 20m.  
 (Note 3) The rated acceleration is 0.3G. Increasing the acceleration will result in lower load capacity.  
 (Note 4) Please note that a longer stroke will result in a lower maximum speed.

\* For other points to note, please refer to page 49.



ICSA3 [ICSPA3] -BF□HB1□

Load Capacity (kg) (Note3)

BF□HB1H

		Y-axis stroke					
		200	300	400	500	600	700
Z-axis stroke	100	3.0					
	200	3.0					
	300	3.0					
	400	3.0					
	500	3.0					

BF□HB1M

		Y-axis stroke					
		200	300	400	500	600	700
Z-axis stroke	100	6.0					
	200	6.0					
	300	6.0					
	400	6.0					
	500	6.0					

BF□HB1L

		Y-axis stroke					
		200	300	400	500	600	700
Z-axis stroke	100	14.0					
	200	14.0					13.5
	300	14.0					12.9
	400	14.0					12.3
	500	14.0					11.7

Maximum Speed by Stroke (mm/sec) (Note4)

BF□HB1H

	Stroke																	
	100	200-500	600	700	1000-1400	1500	1600	1700	1800	1900	2000	2100	2200	2300	2400	2500		
X-axis	-	-	-	-	-	1000	950	830	740	650	590	540	490	440	410	370	300	
Y-axis	-	1000				-	-	-	-	-	-	-	-	-	-	-	-	-
Z-axis	800			-	-	-	-	-	-	-	-	-	-	-	-	-	-	-

BF□HB1M

	Stroke																	
	100	200-500	600	700	1000-1400	1500	1600	1700	1800	1900	2000	2100	2200	2300	2400	2500		
X-axis	-	-	-	-	-	1000	950	830	740	650	590	540	490	440	410	370	300	
Y-axis	-	1000				-	-	-	-	-	-	-	-	-	-	-	-	-
Z-axis	400			-	-	-	-	-	-	-	-	-	-	-	-	-	-	-

BF□HB1L

	Stroke																	
	100	200-500	600	700	1000-1400	1500	1600	1700	1800	1900	2000	2100	2200	2300	2400	2500		
X-axis	-	-	-	-	-	1000	950	830	740	650	590	540	490	440	410	370	300	
Y-axis	-	1000				-	-	-	-	-	-	-	-	-	-	-	-	-
Z-axis	200			-	-	-	-	-	-	-	-	-	-	-	-	-	-	-

Dimensions

\* The dimension below is for XY-axis Configuration direction 1.

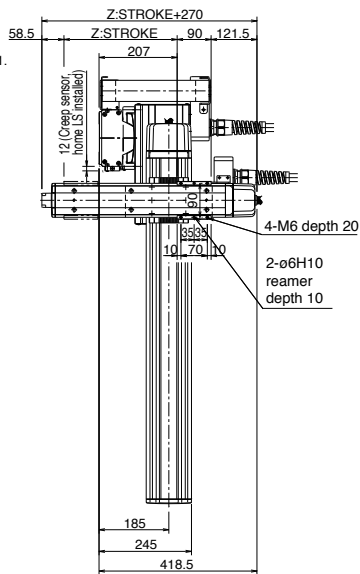

\* The configuration position in the figure is home position. To change the home position, indicate NM in the option. Note that changing the home direction will require the actuator to be returned to IAI for adjustment.

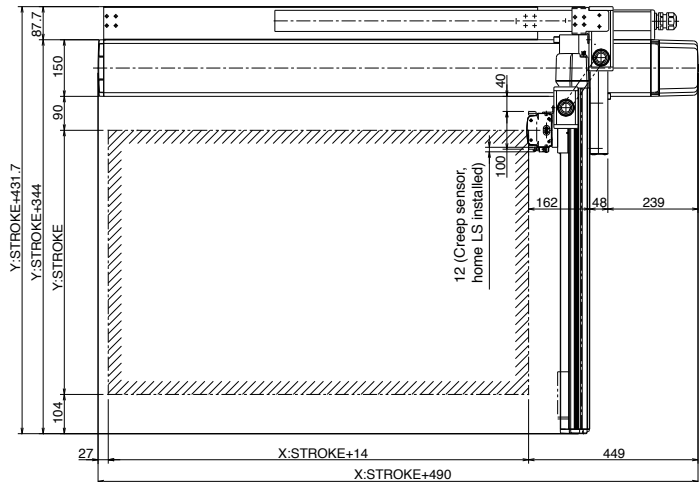

X st	A	B	C	D	Y st	L
1000	225	0	0	12	200	(650)
1100	275	0	0	12	300	(700)
1200	325	0	0	12	400	(750)
1300	375	0	0	12	500	(800)
1400	425	0	0	12	600	(850)
1500	475	0	0	12	700	(900)
1600	525	0	0	12		
1700	575	0	0	12		
1800	200	425	0	16		
1900	200	475	0	16		
2000	200	525	0	16		
2100	200	575	0	16		
2200	200	200	425	20		
2300	200	200	475	20		
2400	200	200	525	20		
2500	200	200	575	20		

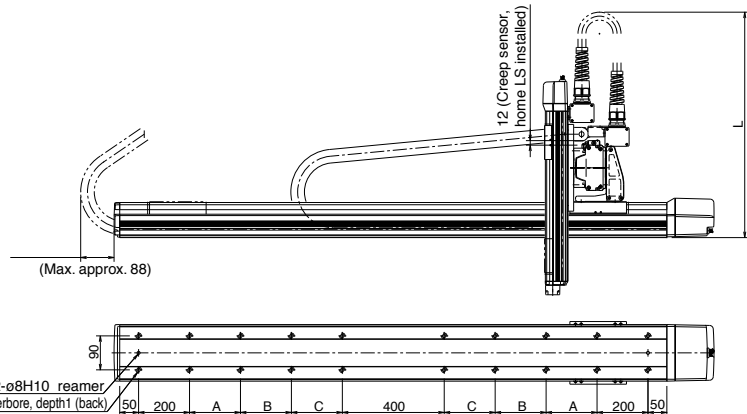

<b>ICSA3-BF</b> <input type="checkbox"/> <b>HB2</b> <input type="checkbox"/>		Cartesian Robot: X-Y-Z 3-Axes Configuration Z-Axis Base Mount Type
<b>ICSPA3-BF</b> <input type="checkbox"/> <b>HB2</b> <input type="checkbox"/>		Cartesian Robot: X-Y-Z 3-Axes Configuration Z-Axis Base Mount Type High-Precision Specification
Type	XYB + Z-Axis Base Mount Type	Stroke / X-axis: 1000-2500mm Y-axis: 200-700mm Z-axis: 100-500mm
		Load capacity / 19kg - 3.5kg
Model specification items	Series	Type
(Example)	ICSA3 (ICSPA3)	- BF1HB2M -
		A - 100AQL - 40AQL - 30BL - T1 - 5L - CT - SC

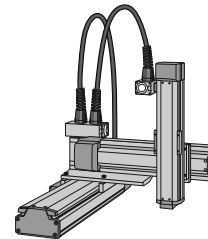

\* Refer to page 51 for the details of model specification items.

**Models/Specifications**

\* [ ] is for the high-precision specification.

Encoder Type	XY-axis configuration direction (*1)	Z-axis type (*2)	Model
Absolute	1	H	ICSA3 [ICSPA3] -BF1HB2H-A- [1]-[2]-[3]-B-T1-[4]-[5]
		M	ICSA3 [ICSPA3] -BF1HB2M-A- [1]-[2]-[3]-B-T1-[4]-[5]
		L	ICSA3 [ICSPA3] -BF1HB2L-A- [1]-[2]-[3]-B-T1-[4]-[5]
	2	H	ICSA3 [ICSPA3] -BF2HB2H-A- [1]-[2]-[3]-B-T1-[4]-[5]
		M	ICSA3 [ICSPA3] -BF2HB2M-A- [1]-[2]-[3]-B-T1-[4]-[5]
		L	ICSA3 [ICSPA3] -BF2HB2L-A- [1]-[2]-[3]-B-T1-[4]-[5]
	3	H	ICSA3 [ICSPA3] -BF3HB2H-A- [1]-[2]-[3]-B-T1-[4]-[5]
		M	ICSA3 [ICSPA3] -BF3HB2M-A- [1]-[2]-[3]-B-T1-[4]-[5]
		L	ICSA3 [ICSPA3] -BF3HB2L-A- [1]-[2]-[3]-B-T1-[4]-[5]
	4	H	ICSA3 [ICSPA3] -BF4HB2H-A- [1]-[2]-[3]-B-T1-[4]-[5]
		M	ICSA3 [ICSPA3] -BF4HB2M-A- [1]-[2]-[3]-B-T1-[4]-[5]
		L	ICSA3 [ICSPA3] -BF4HB2L-A- [1]-[2]-[3]-B-T1-[4]-[5]
Incremental	1	H	ICSA3 [ICSPA3] -BF1HB2H-I- [1]-[2]-[3]-B-T1-[4]-[5]
		M	ICSA3 [ICSPA3] -BF1HB2M-I- [1]-[2]-[3]-B-T1-[4]-[5]
		L	ICSA3 [ICSPA3] -BF1HB2L-I- [1]-[2]-[3]-B-T1-[4]-[5]
	2	H	ICSA3 [ICSPA3] -BF2HB2H-I- [1]-[2]-[3]-B-T1-[4]-[5]
		M	ICSA3 [ICSPA3] -BF2HB2M-I- [1]-[2]-[3]-B-T1-[4]-[5]
		L	ICSA3 [ICSPA3] -BF2HB2L-I- [1]-[2]-[3]-B-T1-[4]-[5]
	3	H	ICSA3 [ICSPA3] -BF3HB2H-I- [1]-[2]-[3]-B-T1-[4]-[5]
		M	ICSA3 [ICSPA3] -BF3HB2M-I- [1]-[2]-[3]-B-T1-[4]-[5]
		L	ICSA3 [ICSPA3] -BF3HB2L-I- [1]-[2]-[3]-B-T1-[4]-[5]
	4	H	ICSA3 [ICSPA3] -BF4HB2H-I- [1]-[2]-[3]-B-T1-[4]-[5]
		M	ICSA3 [ICSPA3] -BF4HB2M-I- [1]-[2]-[3]-B-T1-[4]-[5]
		L	ICSA3 [ICSPA3] -BF4HB2L-I- [1]-[2]-[3]-B-T1-[4]-[5]

\*1: Refer to the figure below for XY-axis configuration direction.  
\*2: The load capacity and the maximum speed may vary depending on the type of Z-axis.  
Note: T1 in the above models will be T2 when operated with XSEL-P/Q type.

**Explanation of Model Code**

Number	Contents	Specification
①	X-axis stroke (Note 1)	100 : 1000mm ~ 250 : 2500mm
②	Y-axis stroke (Note 1)	20 : 200mm ~ 70 : 700mm
③	Z-axis stroke (Note 1)	10 : 100mm ~ 50 : 500mm
④	Cable length (Note 2)	3L : 3m 5L : 5m
⑤	Y-axis/ Z-axis cable management	CT-SC : Self-standing cable (*3) CT-CT : Cable track

\* The above explains the Models/Specifications chart to the left.  
\*3 Only cable track can be specified for the Y-axis cable management with model # BF□HB2□.

**Options**

Please add the option codes at the end of each stroke of the axis.  
When adding multiple options, put together in alphabetic order.

Name	Code	Page
AQ seal	AQ	→P13
Brake	B	→P13
Creep sensor	C	→P13
Home limit switch	L	→P14
Reversed-home specification	NM	→P14
Guide with ball-retaining mechanism	RT	→P14

**Configuration Direction**

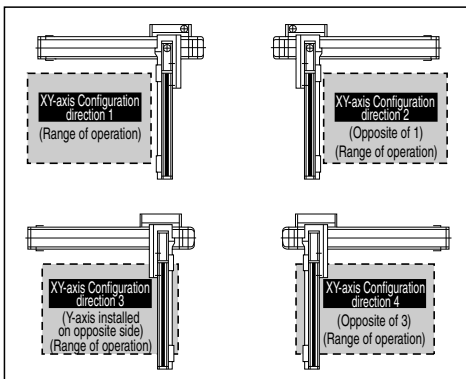

**Common Specifications**

\* [ ] is for the high-precision specification.

Drive system	Ball screw, rolled C10 [equivalent to rolled C5]
Positioning repeatability	±0.02mm [±0.01mm]
Backlash	0.05mm or less [0.02mm or less]
Guide	Integrated with base
Base	Material: Aluminum with white alumite treatment
X-axis motor output / lead	400W / 20mm
Y-axis motor output / lead	200W / 20mm
Z-axis motor output / lead	100W / 20mm (H), 10mm (M), 5mm (L)

**Applicable Controller Specifications**

Refer to page 65 for System Configuration.

**Axis Configuration**

\* [ ] is for the high-precision specification.

Axis Type	Model	Page
X-axis	ISA[ISPA]-LXMX-□-400-20-(Stroke)-T1	→P28
Y-axis	ISA[ISPA]-MYM-□-200-20-(Stroke)-T1	→P22
Z-axis	ISA[ISPA]-MXM-□-100-20/10/5-(Stroke)-T1-B	→P18

\*In the above model name, □ indicates encoder type A (absolute) or I (incremental).

**Caution**

(Note 1) The stroke in the model is specified in cm (centimeters).  
 (Note 2) The cable length measures from the X-axis connector box to the controller. The standard lengths are 3m and 5m, but other lengths can also be specified in meters. The maximum length is 20m.  
 (Note 3) The rated acceleration is 0.3G. Increasing the acceleration will result in lower load capacity.  
 (Note 4) Please note that a longer stroke will result in a lower maximum speed.

\* For other points to note, please refer to page 49.

ICSA3 [ICSPA3] -BF□HB2□

**Load Capacity (kg) (Note3)**

■BF□HB2H

		Y-axis stroke					
		200	300	400	500	600	700
Z-axis stroke	100	3.5					
	200	3.5					
	300	3.5					
	400	3.5					
	500	3.5					

■BF□HB2M

		Y-axis stroke					
		200	300	400	500	600	700
Z-axis stroke	100	9.0					
	200	9.0					
	300	9.0					7.9
	400	9.0					6.9
	500	9.0					5.8

■BF□HB2L

		Y-axis stroke					
		200	300	400	500	600	700
Z-axis stroke	100	19.0	18.0	13.6	10.0		
	200	19.0	17.0	12.6	9.0		
	300	19.0	15.9	11.5	7.9		
	400	19.0	14.9	10.5	6.9		
	500	19.0	13.8	9.4	5.8		

**Maximum Speed by Stroke (mm/sec) (Note4)**

■BF□HB2H

	Stroke																	
	100	200~500	600	700	1000~1400	1500	1600	1700	1800	1900	2000	2100	2200	2300	2400	2500		
X-axis	-	-	-	-	-	1000	950	830	740	650	590	540	490	440	410	370	300	
Y-axis	-	1000				-	-	-	-	-	-	-	-	-	-	-	-	-
Z-axis	1000		-	-	-	-	-	-	-	-	-	-	-	-	-	-	-	

■BF□HB2M

	Stroke																	
	100	200~500	600	700	1000~1400	1500	1600	1700	1800	1900	2000	2100	2200	2300	2400	2500		
X-axis	-	-	-	-	-	1000	950	830	740	650	590	540	490	440	410	370	300	
Y-axis	-	1000				-	-	-	-	-	-	-	-	-	-	-	-	-
Z-axis	500		-	-	-	-	-	-	-	-	-	-	-	-	-	-	-	

■BF□HB2L

	Stroke																	
	100	200~500	600	700	100~1400	1500	1600	1700	1800	1900	2000	2100	2200	2300	2400	2500		
X-axis	-	-	-	-	-	1000	950	830	740	650	590	540	490	440	410	370	300	
Y-axis	-	1000				-	-	-	-	-	-	-	-	-	-	-	-	-
Z-axis	250		-	-	-	-	-	-	-	-	-	-	-	-	-	-	-	

**Dimensions**

\* The dimension below is for XY-axis Configuration direction 1.

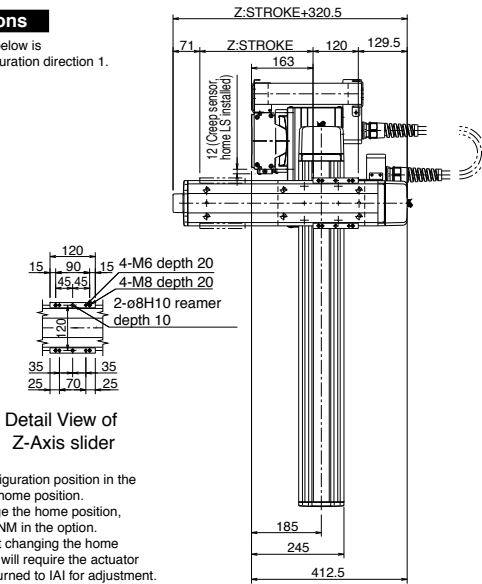

Detail View of Z-Axis slider

\* The configuration position in the figure is home position. To change the home position, indicate NM in the option. Note that changing the home direction will require the actuator to be returned to IAI for adjustment.

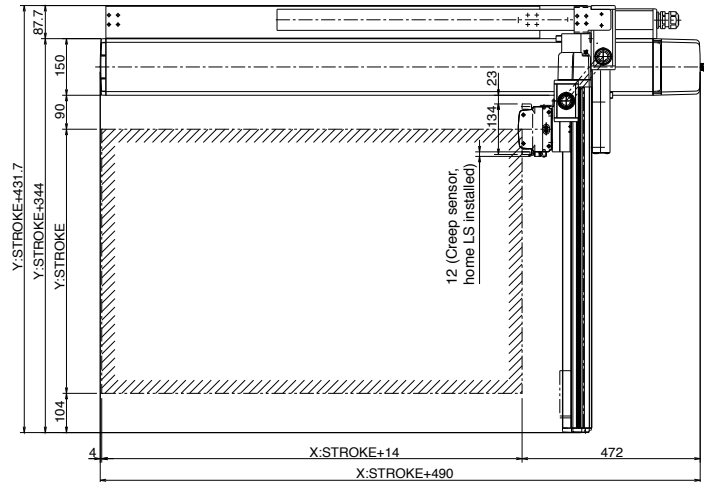

X st	A	B	C	D
1000	225	0	0	12
1100	275	0	0	12
1200	325	0	0	12
1300	375	0	0	12
1400	425	0	0	12
1500	475	0	0	12
1600	525	0	0	12
1700	575	0	0	12
1800	200	425	0	16
1900	200	475	0	16
2000	200	525	0	16
2100	200	575	0	16
2200	200	200	425	20
2300	200	200	475	20
2400	200	200	525	20
2500	200	200	575	20

Y st	L
200	(650)
300	(700)
400	(750)
500	(800)
600	(850)
700	(900)

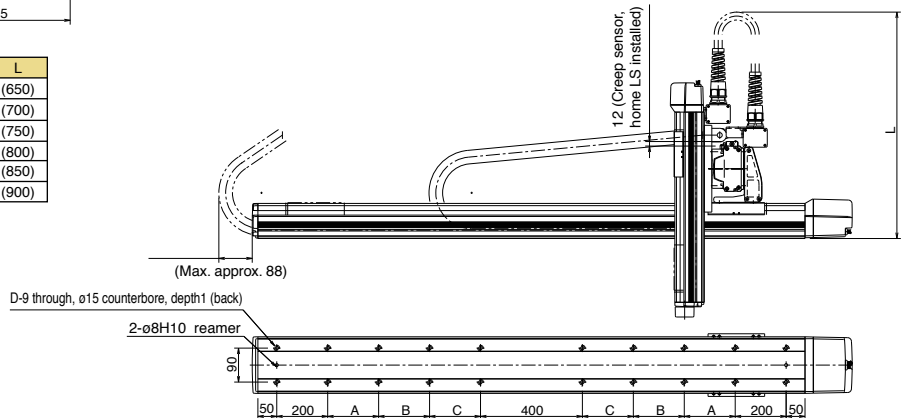

<b>ICSA3-BF</b> <input type="checkbox"/> <b>HB3</b> <input type="checkbox"/>		Cartesian Robot: X-Y-Z 3-Axes Configuration Z-Axis Base Mount Type	
<b>ICSPA3-BF</b> <input type="checkbox"/> <b>HB3</b> <input type="checkbox"/>		Cartesian Robot: X-Y-Z 3-Axes Configuration Z-Axis Base Mount Type High-Precision Specification	
Type	XYB + Z-Axis Base Mount Type	Stroke	X-axis: 1000-2500mm Y-axis: 200-700mm Z-axis: 100-500mm
Load capacity	19kg ~ 5.8kg		
Model specification items	Series	Type	Encoder type
(Example)	ICSA3 (ICSPA3)	BF/ HB3M	A
			100AQL - 40AQL - 30BL - T1 - 5L - CT - SC

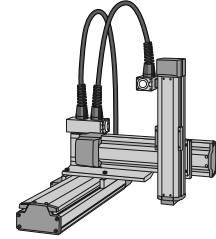

\* Refer to page 51 for the details of model specification items.

**Models/Specifications**

\* [ ] is for the high-precision specification.

Encoder Type	XY-axis configuration direction (*1)	Z-axis type (*2)	Model
Absolute	1	H	ICSA3 [ICSPA3] -BF1HB3H-A- [1] - [2] - [3] -B-T1 - [4] - [5]
		M	ICSA3 [ICSPA3] -BF1HB3M-A- [1] - [2] - [3] -B-T1 - [4] - [5]
	2	H	ICSA3 [ICSPA3] -BF2HB3H-A- [1] - [2] - [3] -B-T1 - [4] - [5]
		M	ICSA3 [ICSPA3] -BF2HB3M-A- [1] - [2] - [3] -B-T1 - [4] - [5]
	3	H	ICSA3 [ICSPA3] -BF3HB3H-A- [1] - [2] - [3] -B-T1 - [4] - [5]
		M	ICSA3 [ICSPA3] -BF3HB3M-A- [1] - [2] - [3] -B-T1 - [4] - [5]
	4	H	ICSA3 [ICSPA3] -BF4HB3H-A- [1] - [2] - [3] -B-T1 - [4] - [5]
		M	ICSA3 [ICSPA3] -BF4HB3M-A- [1] - [2] - [3] -B-T1 - [4] - [5]
Incremental	1	H	ICSA3 [ICSPA3] -BF1HB3H-I- [1] - [2] - [3] -B-T1 - [4] - [5]
		M	ICSA3 [ICSPA3] -BF1HB3M-I- [1] - [2] - [3] -B-T1 - [4] - [5]
	2	H	ICSA3 [ICSPA3] -BF2HB3H-I- [1] - [2] - [3] -B-T1 - [4] - [5]
		M	ICSA3 [ICSPA3] -BF2HB3M-I- [1] - [2] - [3] -B-T1 - [4] - [5]
	3	H	ICSA3 [ICSPA3] -BF3HB3H-I- [1] - [2] - [3] -B-T1 - [4] - [5]
		M	ICSA3 [ICSPA3] -BF3HB3M-I- [1] - [2] - [3] -B-T1 - [4] - [5]
	4	H	ICSA3 [ICSPA3] -BF4HB3H-I- [1] - [2] - [3] -B-T1 - [4] - [5]
		M	ICSA3 [ICSPA3] -BF4HB3M-I- [1] - [2] - [3] -B-T1 - [4] - [5]

\*1: Refer to the figure below for XY-axis configuration direction.  
 \*2: The load capacity and the maximum speed may vary depending on the type of Z-axis.  
 Note: T1 in the above models will be T2 when operated with XSEL-P/Q type.

**Explanation of Model Code**

Number	Contents	Specification
[1]	X-axis stroke (Note 1)	100 : 1000mm ~ 250 : 2500mm
[2]	Y-axis stroke (Note 1)	20 : 200mm ~ 70 : 700mm
[3]	Z-axis stroke (Note 1)	10 : 100mm ~ 50 : 500mm
[4]	Cable length (Note 2)	3L : 3m 5L : 5m
[5]	Y-axis/ Z-axis cable management	CT-SC : Self-standing cable (*3) CT-CT : Cable track

\* The above explains the Models/Specifications chart to the left.  
 \*3 Only cable track can be specified for the Y-axis cable management with model # BF□HB3□.

**Options**

Please add the option codes at the end of each stroke of the axis.  
 When adding multiple options, put together in alphabetic order.

Name	Code	Page
AQ seal	AQ	→P13
Brake	B	→P13
Creep sensor	C	→P13
Home limit switch	L	→P14
Reversed-home specification	NM	→P14
Guide with ball-retaining mechanism	RT	→P14

**Configuration Direction**

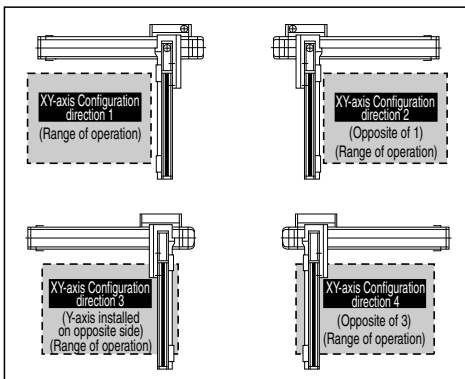

**Common Specifications**

\* [ ] is for the high-precision specification.

Drive system	Ball screw, rolled C10 [equivalent to rolled C5]
Positioning repeatability	±0.02mm [±0.01mm]
Backlash	0.05mm or less [0.02mm or less]
Guide	Integrated with base
Base	Material: Aluminum with white alumite treatment
X-axis motor output / lead	400W / 20mm
Y-axis motor output / lead	200W / 20mm
Z-axis motor output / lead	200W / 20mm (H), 10mm (M)

**Applicable Controller Specifications**

Refer to page 65 for System Configuration.

**Axis Configuration**

\* [ ] is for the high-precision specification.

Axis Type	Model	Page
X-axis	ISA[ISPA]-LXMX-□-400-20-(Stroke)-T1	→P28
Y-axis	ISA[ISPA]-MYM-□-200-20-(Stroke)-T1	→P22
Z-axis	ISA[ISPA]-MXM-□-200-20/10-(Stroke)-T1-B	→P19

\*In the above model name, □ indicates encoder type A (absolute) or I (incremental).

**Caution**

(Note 1) The stroke in the model is specified in cm (centimeters).  
 (Note 2) The cable length measures from the X-axis connector box to the controller. The standard lengths are 3m and 5m, but other lengths can also be specified in meters. The maximum length is 20m.  
 (Note 3) The rated acceleration is 0.3G. Increasing the acceleration will result in lower load capacity.  
 (Note 4) Please note that a longer stroke will result in a lower maximum speed.

\* For other points to note, please refer to page 49.

ICSA3 [ICSPA3] -BF□HB3□

**Load Capacity (kg) (Note3)**

**BF□HB3H**

		Y-axis stroke					
		200	300	400	500	600	700
Z-axis stroke	100	9.0					
	200	9.0					
	300	9.0				7.9	
	400	9.0				6.9	
	500	9.0				5.8	

**BF□HB3M**

		Y-axis stroke					
		200	300	400	500	600	700
Z-axis stroke	100	19.0		18.0	13.6	10.0	
	200	19.0		17.0	12.6	9.0	
	300	19.0		15.9	11.5	7.9	
	300	19.0		14.9	10.5	6.9	
	500	19.0		13.8	9.4	5.8	

**Maximum Speed by Stroke (mm/sec) (Note4)**

**BF□HB3H**

	Stroke																	
	100	200-500	600	700	1000-1400	1500	1600	1700	1800	1900	2000	2100	2200	2300	2400	2500		
X-axis	-	-	-	-	-	1000	950	830	740	650	590	540	490	440	410	370	300	
Y-axis	-	1000				-	-	-	-	-	-	-	-	-	-	-	-	-
Z-axis	1000			-	-	-	-	-	-	-	-	-	-	-	-	-	-	

**BF□HB3M**

	Stroke																	
	100	200-500	600	700	1000-1400	1500	1600	1700	1800	1900	2000	2100	2200	2300	2400	2500		
X-axis	-	-	-	-	-	1000	950	830	740	650	590	540	490	440	410	370	300	
Y-axis	-	1000				-	-	-	-	-	-	-	-	-	-	-	-	-
Z-axis	500			-	-	-	-	-	-	-	-	-	-	-	-	-	-	

**Dimensions**

\* The dimension below is for XY-axis Configuration direction 1.

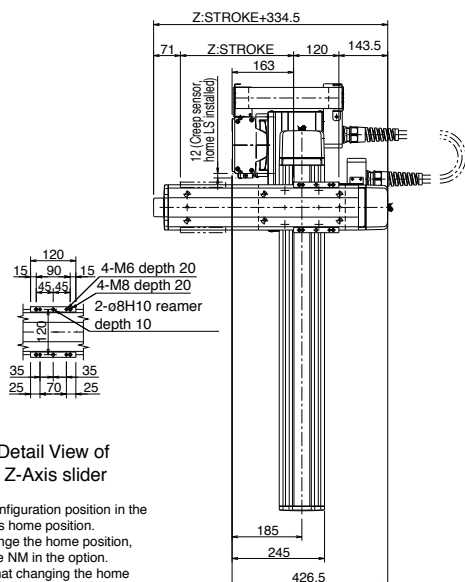

Detail View of Z-Axis slider

\* The configuration position in the figure is home position. To change the home position, indicate NM in the option. Note that changing the home direction will require the actuator to be returned to IAI for adjustment.

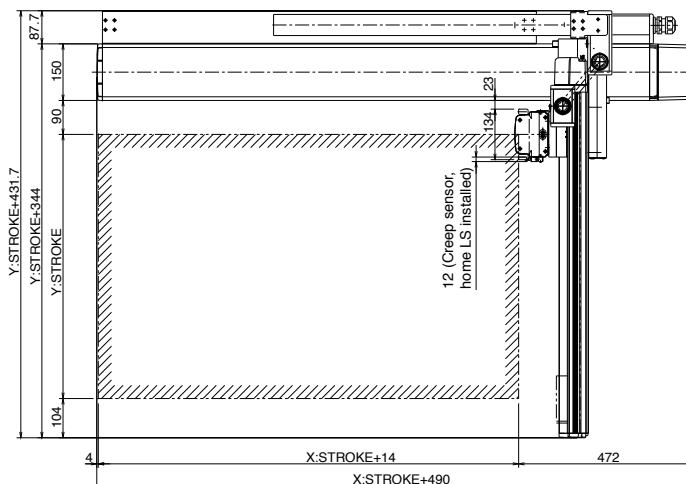

X st	A	B	C	D	Y st	L
1000	225	0	0	12	200	(650)
1100	275	0	0	12	300	(700)
1200	325	0	0	12	400	(750)
1300	375	0	0	12	500	(800)
1400	425	0	0	12	600	(850)
1500	475	0	0	12	700	(900)
1600	525	0	0	12		
1700	575	0	0	12		
1800	200	425	0	16		
1900	200	475	0	16		
2000	200	525	0	16		
2100	200	575	0	16		
2200	200	200	425	20		
2300	200	200	475	20		
2400	200	200	525	20		
2500	200	200	575	20		

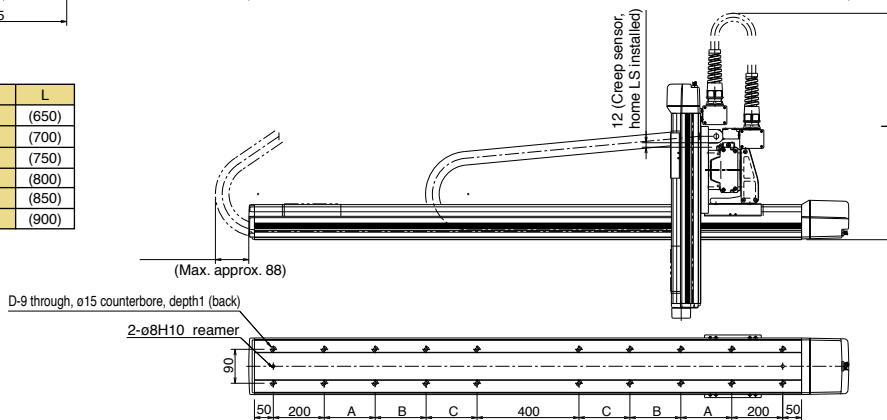

**ICSA3-BA□MS1□** Cartesian Robot: X-Y-Z 3-Axes Configuration  
Z-Axis Slider Mount Type

**ICSPA3-BA□MS1□** Cartesian Robot: X-Y-Z 3-Axes Configuration  
Z-Axis Slider Mount Type High-Precision Specification

Type XYB + Z-Axis Slider Mount Type Stroke X-axis: 100-600mm Y-axis: 100-400mm Z-axis: 100-300mm Load capacity 11kg - 1.6kg

Model specification items	Series	Type	Encoder type	X-axis stroke + options	Y-axis stroke + options	Z-axis stroke + options	Applicable controller	Cable length	Cable management
(Example)	ICSA3 (ICSPA3)	-BA1MS1M-	A	- 60AQL	- 40AQL	- 30BLNM	- T1	- 5L	- SC - SC



\* Refer to page 51 for the details of model specification items.

**Models/Specifications**

\* [ ] is for the high-precision specification.

Encoder Type	XY-axis configuration direction (*1)	Z-axis type (*2)	Model
Absolute	1	M	ICSA3 [ICSPA3] -BA1MS1M-A-①-②-③-BNM-T1-④-⑤
		L	ICSA3 [ICSPA3] -BA1MS1L-A-①-②-③-BNM-T1-④-⑤
	2	M	ICSA3 [ICSPA3] -BA2MS1M-A-①-②-③-BNM-T1-④-⑤
		L	ICSA3 [ICSPA3] -BA2MS1L-A-①-②-③-BNM-T1-④-⑤
	3	M	ICSA3 [ICSPA3] -BA3MS1M-A-①-②-③-BNM-T1-④-⑤
		L	ICSA3 [ICSPA3] -BA3MS1L-A-①-②-③-BNM-T1-④-⑤
4	M	ICSA3 [ICSPA3] -BA4MS1M-A-①-②-③-BNM-T1-④-⑤	
	L	ICSA3 [ICSPA3] -BA4MS1L-A-①-②-③-BNM-T1-④-⑤	
Incremental	1	M	ICSA3 [ICSPA3] -BA1MS1M-I-①-②-③-BNM-T1-④-⑤
		L	ICSA3 [ICSPA3] -BA1MS1L-I-①-②-③-BNM-T1-④-⑤
	2	M	ICSA3 [ICSPA3] -BA2MS1M-I-①-②-③-BNM-T1-④-⑤
		L	ICSA3 [ICSPA3] -BA2MS1L-I-①-②-③-BNM-T1-④-⑤
	3	M	ICSA3 [ICSPA3] -BA3MS1M-I-①-②-③-BNM-T1-④-⑤
		L	ICSA3 [ICSPA3] -BA3MS1L-I-①-②-③-BNM-T1-④-⑤
	4	M	ICSA3 [ICSPA3] -BA4MS1M-I-①-②-③-BNM-T1-④-⑤
		L	ICSA3 [ICSPA3] -BA4MS1L-I-①-②-③-BNM-T1-④-⑤

\*1: Refer to the figure below for XY-axis configuration direction.  
\*2: The load capacity and the maximum speed may vary depending on the type of Z-axis.  
Note: T1 in the above models will be T2 when operated with XSEL-P/Q type.

**Explanation of Model Code**

Number	Contents	Specification
①	X-axis stroke (Note 1)	10 : 100mm ~ 60 : 600mm
②	Y-axis stroke (Note 1)	10 : 100mm ~ 40 : 400mm
③	Z-axis stroke (Note 1)	10 : 100mm ~ 30 : 300mm
④	Cable length (Note 2)	3L : 3m 5L : 5m
⑤	Y-axis/ Z-axis cable management	SC-SC : Self-standing cable

\* The above explains the Models/Specifications chart to the left.

**Options**

Please add the option codes at the end of each stroke of the axis. When adding multiple options, put together in alphabetic order.

Name	Code	Page
AQ seal	AQ	→P13
Brake	B	→P13
Creep sensor	C	→P13
Home limit switch	L	→P14
Reversed-home specification	NM	→P14
Guide with ball-retaining mechanism	RT	→P14

**Configuration Direction**

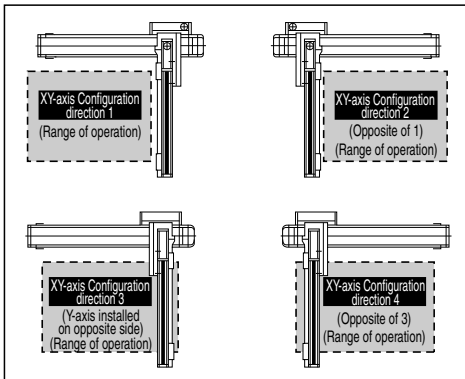

**Common Specifications**

\* [ ] is for the high-precision specification.

Drive system	Ball screw, rolled C10 [equivalent to rolled C5]
Positioning repeatability	±0.02mm [±0.01mm]
Backlash	0.05mm or less [0.02mm or less]
Guide	Integrated with base
Base	Material: Aluminum with white alumite treatment
X-axis motor output / lead	60W / 8mm
Y-axis motor output / lead	60W / 8mm
Z-axis motor output / lead	60W / 8mm (M), 4mm (L)

**Applicable Controller Specifications**

Refer to page 65 for System Configuration.

**Axis Configuration**

\* [ ] is for the high-precision specification.

Axis Type	Model	Page
X-axis	ISA[ISPA]-SXM-□-60-8-(Stroke)-T1	→P15
Y-axis	ISA[ISPA]-SYM-□-60-8-(Stroke)-T1	→P16
Z-axis	ISA[ISPA]-SZM-□-60-8/4-(Stroke)-T1-B-NM	→P17

\*In the above model name, □ indicates encoder type A (absolute) or I (incremental).

**Caution**

(Note 1) The stroke in the model is specified in cm (centimeters).  
 (Note 2) The cable length measures from the X-axis connector box to the controller. The standard lengths are 3m and 5m, but other lengths can also be specified in meters. The maximum length is 20m.  
 (Note 3) The rated acceleration is 0.3G. Increasing the acceleration will result in lower load capacity.  
 (Note 4) Please note that a longer stroke will result in a lower maximum speed.

\* For other points to note, please refer to page 49.

ICSA3 [ICSPA3] -BA□MS1□

**Load Capacity (kg) (Note3)**

**BA□MS1M**

		Y-axis stroke			
		100	200	300	400
Z-axis stroke	100	3.0			
	200	2.3			
	300	1.6			

**BA□MS1L**

		Y-axis stroke			
		100	200	300	400
Z-axis stroke	100	11.0	7.6	3.6	
	200	10.3	6.9	2.9	
	300	9.6	6.2	2.2	

**Maximum Speed by Stroke (mm/sec) (Note4)**

**BA□MS1M**

	Stroke					
	100	200	300	400	500	600
X-axis	400					
Y-axis	400		-	-	-	-
Z-axis	400	-	-	-	-	-

**BA□MS1L**

	Stroke					
	100	200	300	400	500	600
X-axis	400					
Y-axis	400		-	-	-	-
Z-axis	200	-	-	-	-	-

**Dimensions**

\* The dimension below is for XY-axis Configuration direction 1.

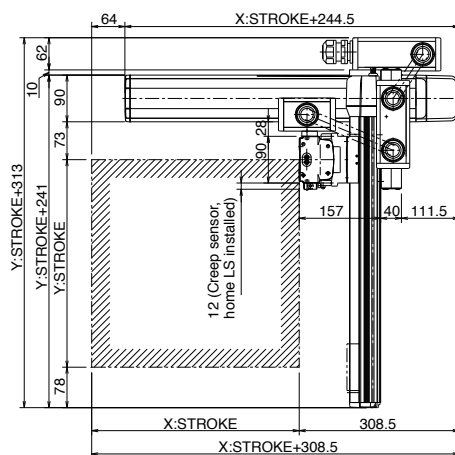
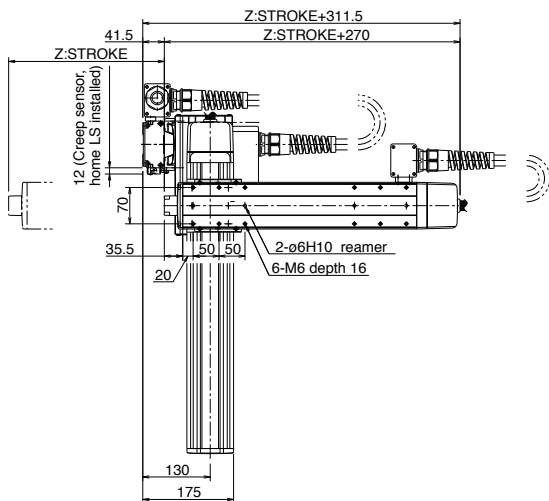

\* The configuration position in the figure is home position. To change the home position, indicate NM in the option. Note that changing the home direction will require the actuator to be returned to IAI for adjustment.

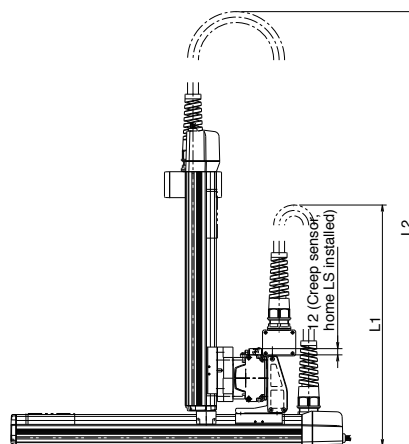

X stroke	100	200	300	400	500	600
L1	(500)	(550)	(600)	(650)	(700)	(750)
A	151	251	151	251	151	251
B	0	0	1	1	2	2
C	4	4	6	6	8	8

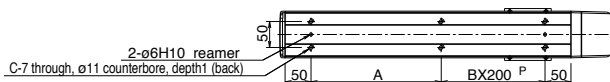

		Y stroke			
		100	200	300	400
Z stroke	100	(610)	(660)	(710)	(760)
	200	(710)	(750)	(810)	(860)
	300	(810)	(860)	(910)	(960)

<b>ICSA3-BB HS1</b>		Cartesian Robot: X-Y-Z 3-Axes Configuration Z-Axis Slider Mount Type	
<b>ICSPA3-BB HS1</b>		Cartesian Robot: X-Y-Z 3-Axes Configuration Z-Axis Slider Mount Type High-Precision Specification	
Type	XYB + Z-Axis Slider Mount Type	Stroke	X-axis: 200-800mm Y-axis: 100-400mm Z-axis: 100-300mm
Load capacity	7.2kg - 1.6kg		
Model specification items	Series	Type	Encoder type
(Example)	ICSA3 (ICSPA3)	-BBHS1M-	A
			- 60AQL - 40AQL - 30BLM - T1 - 5L - SC - SC



\* Refer to page 51 for the details of model specification items.

**Models/Specifications**

\* [ ] is for the high-precision specification.

Encoder Type	XY-axis configuration direction (*1)	Z-axis type (*2)	Model
Absolute	1	M	ICSA3 [ICSPA3] -BB1HS1M-A-[1]-[2]-[3]-BNM-T1-[4]-[5]
		L	ICSA3 [ICSPA3] -BB1HS1L-A-[1]-[2]-[3]-BNM-T1-[4]-[5]
	2	M	ICSA3 [ICSPA3] -BB2HS1M-A-[1]-[2]-[3]-BNM-T1-[4]-[5]
		L	ICSA3 [ICSPA3] -BB2HS1L-A-[1]-[2]-[3]-BNM-T1-[4]-[5]
	3	M	ICSA3 [ICSPA3] -BB3HS1M-A-[1]-[2]-[3]-BNM-T1-[4]-[5]
		L	ICSA3 [ICSPA3] -BB3HS1L-A-[1]-[2]-[3]-BNM-T1-[4]-[5]
	4	M	ICSA3 [ICSPA3] -BB4HS1M-A-[1]-[2]-[3]-BNM-T1-[4]-[5]
		L	ICSA3 [ICSPA3] -BB4HS1L-A-[1]-[2]-[3]-BNM-T1-[4]-[5]
Incremental	1	M	ICSA3 [ICSPA3] -BB1HS1M-I-[1]-[2]-[3]-BNM-T1-[4]-[5]
		L	ICSA3 [ICSPA3] -BB1HS1L-I-[1]-[2]-[3]-BNM-T1-[4]-[5]
	2	M	ICSA3 [ICSPA3] -BB2HS1M-I-[1]-[2]-[3]-BNM-T1-[4]-[5]
		L	ICSA3 [ICSPA3] -BB2HS1L-I-[1]-[2]-[3]-BNM-T1-[4]-[5]
	3	M	ICSA3 [ICSPA3] -BB3HS1M-I-[1]-[2]-[3]-BNM-T1-[4]-[5]
		L	ICSA3 [ICSPA3] -BB3HS1L-I-[1]-[2]-[3]-BNM-T1-[4]-[5]
	4	M	ICSA3 [ICSPA3] -BB4HS1M-I-[1]-[2]-[3]-BNM-T1-[4]-[5]
		L	ICSA3 [ICSPA3] -BB4HS1L-I-[1]-[2]-[3]-BNM-T1-[4]-[5]

\*1: Refer to the figure below for XY-axis configuration direction.  
 \*2: The load capacity and the maximum speed may vary depending on the type of Z-axis.  
 Note: T1 in the above models will be T2 when operated with XSEL-P/Q type.

**Explanation of Model Code**

Number	Contents	Specification
①	X-axis stroke (Note 1)	20 : 80mm ~ 80 : 800mm
②	Y-axis stroke (Note 1)	10 : 100mm ~ 40 : 400mm
③	Z-axis stroke (Note 1)	10 : 100mm ~ 30 : 300mm
④	Cable length (Note 2)	3L : 3m 5L : 5m
⑤	Y-axis/ Z-axis cable management	SC-SC : Self-standing cable

\* The above explains the Models/Specifications chart to the left.

**Options**

Please add the option codes at the end of each stroke of the axis.  
 When adding multiple options, put together in alphabetic order.

Name	Code	Page
AQ seal	AQ	→P13
Brake	B	→P13
Creep sensor	C	→P13
Home limit switch	L	→P14
Reversed-home specification	NM	→P14
Guide with ball-retaining mechanism	RT	→P14

**Configuration Direction**

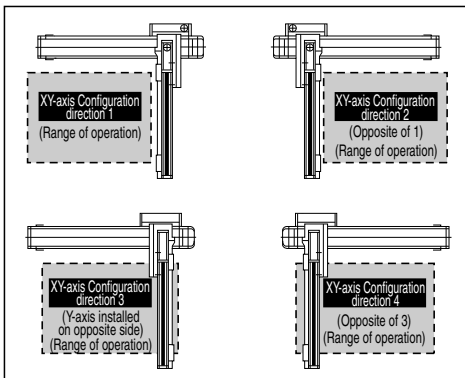

**Common Specifications**

\* [ ] is for the high-precision specification.

Drive system	Ball screw, rolled C10 [equivalent to rolled C5]
Positioning repeatability	±0.02mm [±0.01mm]
Backlash	0.05mm or less [0.02mm or less]
Guide	Integrated with base
Base	Material: Aluminum with white alumite treatment
X-axis motor output / lead	100W / 20mm
Y-axis motor output / lead	60W / 16mm
Z-axis motor output / lead	60W / 8mm (M), 4mm (L)

**Applicable Controller Specifications**

Refer to page 65 for System Configuration.

**Axis Configuration**

\* [ ] is for the high-precision specification.

Axis Type	Model	Page
X-axis	ISA[ISPA]-MXM-[ ]-100-20-(Stroke)-T1	→P18
Y-axis	ISA[ISPA]-SYM-[ ]-60-16-(Stroke)-T1	→P16
Z-axis	ISA[ISPA]-SZM-[ ]-60-8/4-(Stroke)-T1-B-NM	→P17

\*In the above model name, [ ] indicates encoder type A (absolute) or I (incremental).

**Caution**

(Note 1) The stroke in the model is specified in cm (centimeters).  
 (Note 2) The cable length measures from the X-axis connector box to the controller. The standard lengths are 3m and 5m, but other lengths can also be specified in meters. The maximum length is 20m.  
 (Note 3) The rated acceleration is 0.3G. Increasing the acceleration will result in lower load capacity.  
 (Note 4) Please note that a longer stroke will result in a lower maximum speed.

\* For other points to note, please refer to page 49.



ICSA3 [ICSPA3] - BB□HS1□

Load Capacity (kg) (Note3)

BB□HS1M

		Y-axis stroke			
		100	200	300	400
Z-axis stroke	100	3.0			
	200	2.3			
	300	1.6			

BB□HS1L

		Y-axis stroke			
		100	200	300	400
Z-axis stroke	100	7.2	7.0	6.3	
	200	6.5	6.3	5.6	
	300	5.8	5.6	4.9	

Maximum Speed by Stroke (mm/sec) (Note4)

BB□HS1M

	Stroke								
	100	200	300	400	500	600	700	800	
X-axis	-	1000						795	
Y-axis	800			-	-	-	-	-	
Z-axis	400		-	-	-	-	-	-	

BB□HS1L

	Stroke								
	100	200	300	400	500	600	700	800	
X-axis	-	1000						795	
Y-axis	800			-	-	-	-	-	
Z-axis	200		-	-	-	-	-	-	

Dimensions

\* The dimension below is for XY-axis Configuration direction 1.

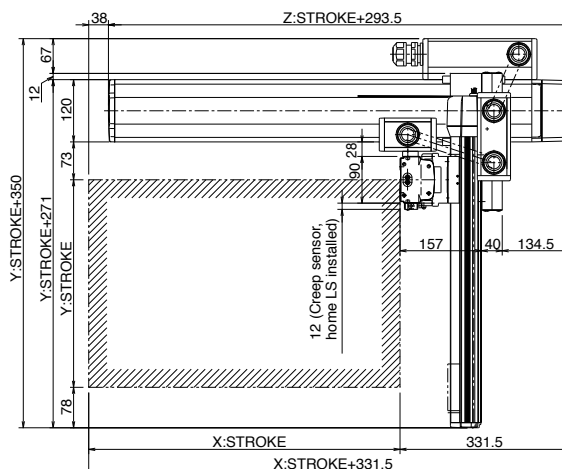
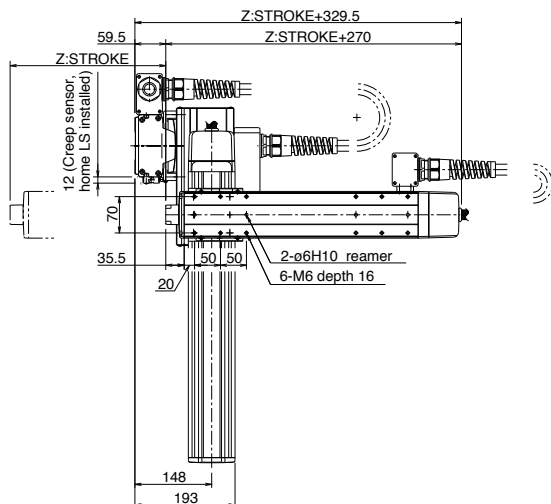

\* The configuration position in the figure is home position. To change the home position, indicate NM in the option. Note that changing the home direction will require the actuator to be returned to IAI for adjustment.

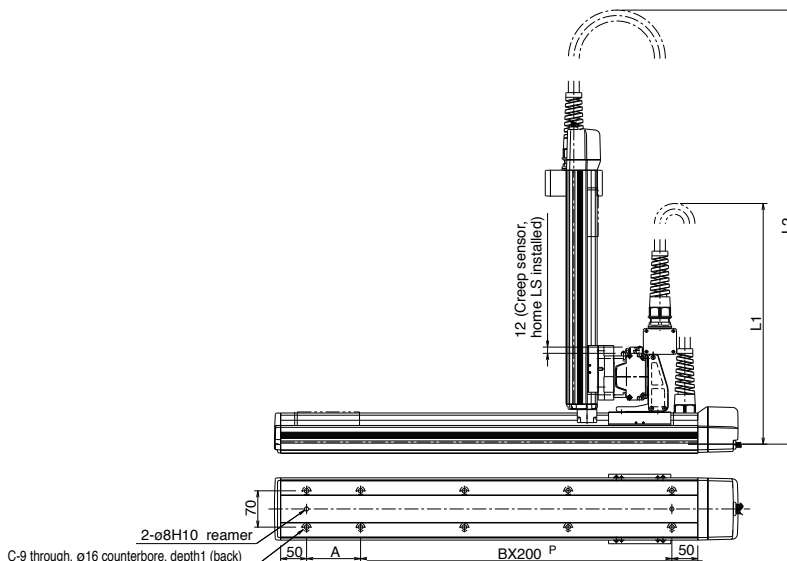

X stroke	200	300	400	500	600	700	800
L1	(550)	(600)	(650)	(700)	(750)	(800)	(850)
A	104	204	104	204	104	204	104
B	1	1	2	2	3	3	4
C	6	6	8	8	10	10	12

Z stroke	Y stroke				
	100	200	300	400	
	100	(630)	(680)	(730)	(780)
200	(730)	(780)	(830)	(880)	
300	(830)	(880)	(930)	(980)	

<b>ICSA3-BB</b> <input type="checkbox"/> <b>MS1</b> <input type="checkbox"/>		Cartesian Robot: X-Y-Z 3-Axes Configuration Z-Axis Slider Mount Type	
<b>ICSPA3-BB</b> <input type="checkbox"/> <b>MS1</b> <input type="checkbox"/>		Cartesian Robot: X-Y-Z 3-Axes Configuration Z-Axis Slider Mount Type <b>High-Precision Specification</b>	
Type	XYB + Z-Axis Slider Mount Type	Stroke	X-axis: 200-800mm Y-axis: 100-400mm Z-axis: 100-300mm
Load capacity	11kg - 1.6kg		
Model specification items	Series	Type	Encoder type
(Example)	ICSA3 (ICSPA3)	-BB1MS1M-	A
			- 60AQL - 40AQL - 30BLNM - T1 - 5L - SC - SC



\* Refer to page 51 for the details of model specification items.

**Models/Specifications**

\* [ ] is for the high-precision specification.

Encoder Type	XY-axis configuration direction (*1)	Z-axis type (*2)	Model
Absolute	1	M	ICSA3 [ICSPA3] -BB1MS1M-A- <input type="checkbox"/> - <input type="checkbox"/> - <input type="checkbox"/> -BNM-T1- <input type="checkbox"/> - <input type="checkbox"/>
		L	ICSA3 [ICSPA3] -BB1MS1L-A- <input type="checkbox"/> - <input type="checkbox"/> - <input type="checkbox"/> -BNM-T1- <input type="checkbox"/> - <input type="checkbox"/>
	2	M	ICSA3 [ICSPA3] -BB2MS1M-A- <input type="checkbox"/> - <input type="checkbox"/> - <input type="checkbox"/> -BNM-T1- <input type="checkbox"/> - <input type="checkbox"/>
		L	ICSA3 [ICSPA3] -BB2MS1L-A- <input type="checkbox"/> - <input type="checkbox"/> - <input type="checkbox"/> -BNM-T1- <input type="checkbox"/> - <input type="checkbox"/>
	3	M	ICSA3 [ICSPA3] -BB3MS1M-A- <input type="checkbox"/> - <input type="checkbox"/> - <input type="checkbox"/> -BNM-T1- <input type="checkbox"/> - <input type="checkbox"/>
		L	ICSA3 [ICSPA3] -BB3MS1L-A- <input type="checkbox"/> - <input type="checkbox"/> - <input type="checkbox"/> -BNM-T1- <input type="checkbox"/> - <input type="checkbox"/>
4	M	ICSA3 [ICSPA3] -BB4MS1M-A- <input type="checkbox"/> - <input type="checkbox"/> - <input type="checkbox"/> -BNM-T1- <input type="checkbox"/> - <input type="checkbox"/>	
	L	ICSA3 [ICSPA3] -BB4MS1L-A- <input type="checkbox"/> - <input type="checkbox"/> - <input type="checkbox"/> -BNM-T1- <input type="checkbox"/> - <input type="checkbox"/>	
Incremental	1	M	ICSA3 [ICSPA3] -BB1MS1M-I- <input type="checkbox"/> - <input type="checkbox"/> - <input type="checkbox"/> -BNM-T1- <input type="checkbox"/> - <input type="checkbox"/>
		L	ICSA3 [ICSPA3] -BB1MS1L-I- <input type="checkbox"/> - <input type="checkbox"/> - <input type="checkbox"/> -BNM-T1- <input type="checkbox"/> - <input type="checkbox"/>
	2	M	ICSA3 [ICSPA3] -BB2MS1M-I- <input type="checkbox"/> - <input type="checkbox"/> - <input type="checkbox"/> -BNM-T1- <input type="checkbox"/> - <input type="checkbox"/>
		L	ICSA3 [ICSPA3] -BB2MS1L-I- <input type="checkbox"/> - <input type="checkbox"/> - <input type="checkbox"/> -BNM-T1- <input type="checkbox"/> - <input type="checkbox"/>
	3	M	ICSA3 [ICSPA3] -BB3MS1M-I- <input type="checkbox"/> - <input type="checkbox"/> - <input type="checkbox"/> -BNM-T1- <input type="checkbox"/> - <input type="checkbox"/>
		L	ICSA3 [ICSPA3] -BB3MS1L-I- <input type="checkbox"/> - <input type="checkbox"/> - <input type="checkbox"/> -BNM-T1- <input type="checkbox"/> - <input type="checkbox"/>
	4	M	ICSA3 [ICSPA3] -BB4MS1M-I- <input type="checkbox"/> - <input type="checkbox"/> - <input type="checkbox"/> -BNM-T1- <input type="checkbox"/> - <input type="checkbox"/>
		L	ICSA3 [ICSPA3] -BB4MS1L-I- <input type="checkbox"/> - <input type="checkbox"/> - <input type="checkbox"/> -BNM-T1- <input type="checkbox"/> - <input type="checkbox"/>

\*1: Refer to the figure below for XY-axis configuration direction.  
\*2: The load capacity and the maximum speed may vary depending on the type of Z-axis.  
Note: T1 in the above models will be T2 when operated with XSEL-P/Q type.

**Explanation of Model Code**

Number	Contents	Specification
<input type="checkbox"/>	X-axis stroke (Note 1)	20 : 200mm ~ 80 : 800mm
<input type="checkbox"/>	Y-axis stroke (Note 1)	10 : 100mm ~ 40 : 400mm
<input type="checkbox"/>	Z-axis stroke (Note 1)	10 : 100mm ~ 30 : 300mm
<input type="checkbox"/>	Cable length (Note 2)	3L : 3m 5L : 5m
<input type="checkbox"/>	Y-axis/ Z-axis cable management	SC-SC : Self-standing cable

\* The above explains the Models/Specifications chart to the left.

**Options**

Please add the option codes at the end of each stroke of the axis. When adding multiple options, put together in alphabetic order.

Name	Code	Page
AQ seal	AQ	→P13
Brake	B	→P13
Creep sensor	C	→P13
Home limit switch	L	→P14
Reversed-home specification	NM	→P14
Guide with ball-retaining mechanism	RT	→P14

**Configuration Direction**

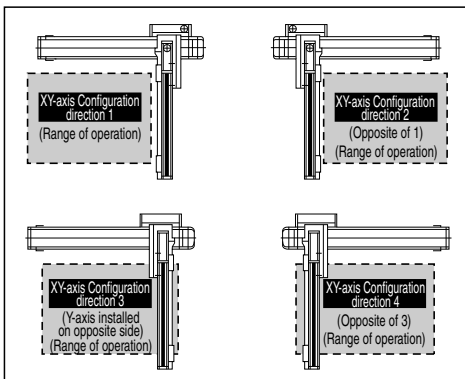

**Common Specifications**

\* [ ] is for the high-precision specification.

Drive system	Ball screw, rolled C10 [equivalent to rolled C5]
Positioning repeatability	±0.02mm [±0.01mm]
Backlash	0.05mm or less [0.02mm or less]
Guide	Integrated with base
Base	Material: Aluminum with white alumite treatment
X-axis motor output / lead	100W / 10mm
Y-axis motor output / lead	60W / 8mm
Z-axis motor output / lead	60W / 8mm (M), 4mm (L)

**Applicable Controller Specifications**

Refer to page 65 for System Configuration.

**Axis Configuration**

\* [ ] is for the high-precision specification.

Axis Type	Model	Page
X-axis	ISA[ISPA]-MXM- <input type="checkbox"/> -100-10-(Stroke)-T1	→P18
Y-axis	ISA[ISPA]-SYM- <input type="checkbox"/> -60-8-(Stroke)-T1	→P16
Z-axis	ISA[ISPA]-SZM- <input type="checkbox"/> -60-8/4-(Stroke)-T1-B-NM	→P17

\*In the above model name,  indicates encoder type A (absolute) or I (incremental).

**Caution**

(Note 1) The stroke in the model is specified in cm (centimeters).  
 (Note 2) The cable length measures from the X-axis connector box to the controller. The standard lengths are 3m and 5m, but other lengths can also be specified in meters. The maximum length is 20m.  
 (Note 3) The rated acceleration is 0.3G. Increasing the acceleration will result in lower load capacity.  
 (Note 4) Please note that a longer stroke will result in a lower maximum speed.

\* For other points to note, please refer to page 49.

ICSA3 [ICSPA3] - BB□MS1□

Load Capacity (kg) (Note3)

BB□MS1M

		Y-axis stroke			
		100	200	300	400
Z-axis stroke	100	3.0			
	200	2.3			
	300	1.6			

BB□MS1L

		Y-axis stroke			
		100	200	300	400
Z-axis stroke	100	11.0			
	200	10.3			
	300	9.6			

Maximum Speed by Stroke (mm/sec) (Note4)

BB□MS1M

	Stroke							
	100	200	300	400	500	600	700	800
X-axis	-	500			480			380
Y-axis	400			-	-	-	-	-
Z-axis	400		-	-	-	-	-	-

BB□MS1L

	Stroke							
	100	200	300	400	500	600	700	800
X-axis	-	500			480			380
Y-axis	400			-	-	-	-	-
Z-axis	200		-	-	-	-	-	-

Dimensions

\* The dimension below is for XY-axis Configuration direction 1.

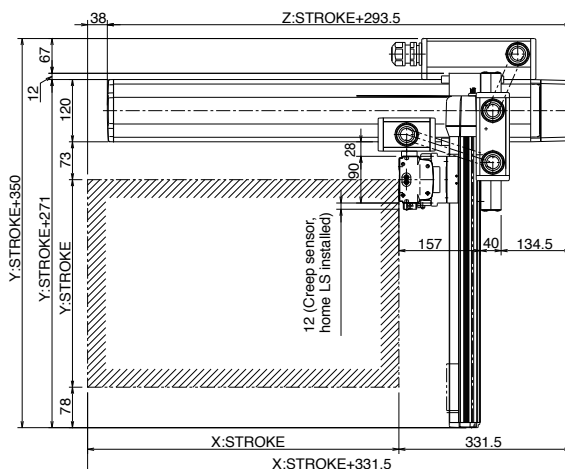
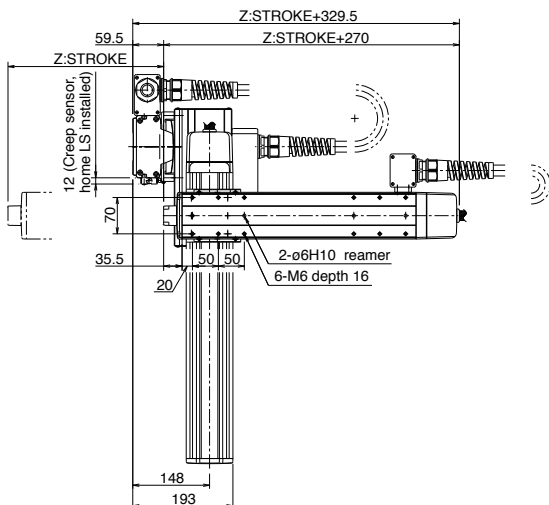

\* The configuration position in the figure is home position. To change the home position, indicate NM in the option. Note that changing the home direction will require the actuator to be returned to IAI for adjustment.

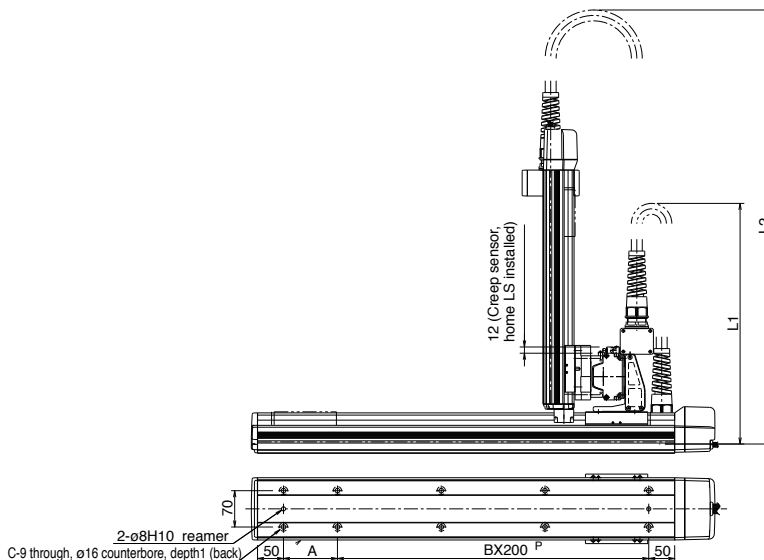

X stroke	200	300	400	500	600	700	800
L1	(550)	(600)	(650)	(700)	(750)	(800)	(850)
A	104	204	104	204	104	204	104
B	1	1	2	2	3	3	4
C	6	6	8	8	10	10	12

		Y stroke			
		100	200	300	400
Z stroke	100	(630)	(680)	(730)	(780)
	200	(730)	(780)	(830)	(880)
	300	(830)	(880)	(930)	(980)

<b>ICSA3-BC</b> <input type="checkbox"/> <b>HS1</b> <input type="checkbox"/>		Cartesian Robot: X-Y-Z 3-Axes Configuration Z-Axis Slider Mount Type	
<b>ICSPA3-BC</b> <input type="checkbox"/> <b>HS1</b> <input type="checkbox"/>		Cartesian Robot: X-Y-Z 3-Axes Configuration Z-Axis Slidr Mount Type High-Precision Specification	
Type	XYB + Z-Axis Slider Mount Type	Stroke	X-axis: 200-800mm Y-axis: 100-500mm Z-axis: 100-300mm
Load capacity	10kg - 1.6kg		
Model specification items	Series	Type	Encoder type
(Example)	ICSA3 (ICSPA3)	-BC1HS1M-	A
			- 70AQL - 40AQL - 30BLNM - T1 - 5L - SC - SC



\* Refer to page 51 for the details of model specification items.

**Models/Specifications**

\* [ ] is for the high-precision specification.

Encoder Type	XY-axis configuration direction (*1)	Z-axis type (*2)	Model
Absolute	1	M	ICSA3 [ICSPA3] -BC1HS1M-A- <input type="checkbox"/> - <input type="checkbox"/> - <input type="checkbox"/> -BNM-T1- <input type="checkbox"/> - <input type="checkbox"/>
		L	ICSA3 [ICSPA3] -BC1HS1L-A- <input type="checkbox"/> - <input type="checkbox"/> - <input type="checkbox"/> -BNM-T1- <input type="checkbox"/> - <input type="checkbox"/>
	2	M	ICSA3 [ICSPA3] -BC2HS1M-A- <input type="checkbox"/> - <input type="checkbox"/> - <input type="checkbox"/> -BNM-T1- <input type="checkbox"/> - <input type="checkbox"/>
		L	ICSA3 [ICSPA3] -BC2HS1L-A- <input type="checkbox"/> - <input type="checkbox"/> - <input type="checkbox"/> -BNM-T1- <input type="checkbox"/> - <input type="checkbox"/>
	3	M	ICSA3 [ICSPA3] -BC3HS1M-A- <input type="checkbox"/> - <input type="checkbox"/> - <input type="checkbox"/> -BNM-T1- <input type="checkbox"/> - <input type="checkbox"/>
		L	ICSA3 [ICSPA3] -BC3HS1L-A- <input type="checkbox"/> - <input type="checkbox"/> - <input type="checkbox"/> -BNM-T1- <input type="checkbox"/> - <input type="checkbox"/>
Incremental	1	M	ICSA3 [ICSPA3] -BC1HS1M-I- <input type="checkbox"/> - <input type="checkbox"/> - <input type="checkbox"/> -BNM-T1- <input type="checkbox"/> - <input type="checkbox"/>
		L	ICSA3 [ICSPA3] -BC1HS1L-I- <input type="checkbox"/> - <input type="checkbox"/> - <input type="checkbox"/> -BNM-T1- <input type="checkbox"/> - <input type="checkbox"/>
	2	M	ICSA3 [ICSPA3] -BC2HS1M-I- <input type="checkbox"/> - <input type="checkbox"/> - <input type="checkbox"/> -BNM-T1- <input type="checkbox"/> - <input type="checkbox"/>
		L	ICSA3 [ICSPA3] -BC2HS1L-I- <input type="checkbox"/> - <input type="checkbox"/> - <input type="checkbox"/> -BNM-T1- <input type="checkbox"/> - <input type="checkbox"/>
	3	M	ICSA3 [ICSPA3] -BC3HS1M-I- <input type="checkbox"/> - <input type="checkbox"/> - <input type="checkbox"/> -BNM-T1- <input type="checkbox"/> - <input type="checkbox"/>
		L	ICSA3 [ICSPA3] -BC3HS1L-I- <input type="checkbox"/> - <input type="checkbox"/> - <input type="checkbox"/> -BNM-T1- <input type="checkbox"/> - <input type="checkbox"/>
4	M	ICSA3 [ICSPA3] -BC4HS1M-I- <input type="checkbox"/> - <input type="checkbox"/> - <input type="checkbox"/> -BNM-T1- <input type="checkbox"/> - <input type="checkbox"/>	
	L	ICSA3 [ICSPA3] -BC4HS1L-I- <input type="checkbox"/> - <input type="checkbox"/> - <input type="checkbox"/> -BNM-T1- <input type="checkbox"/> - <input type="checkbox"/>	

\*1: Refer to the figure below for XY-axis configuration direction.  
\*2: The load capacity and the maximum speed may vary depending on the type of Z-axis.  
Note: T1 in the above models will be T2 when operated with XSEL-P/Q type.

**Explanation of Model Code**

Number	Contents	Specification
<input type="checkbox"/>	X-axis stroke (Note 1)	20 : 80mm ~ 80 : 800mm
<input type="checkbox"/>	Y-axis stroke (Note 1)	10 : 100mm ~ 50 : 500mm
<input type="checkbox"/>	Z-axis stroke (Note 1)	10 : 100mm ~ 30 : 300mm
<input type="checkbox"/>	Cable length (Note 2)	3L : 3m 5L : 5m
<input type="checkbox"/>	Y-axis/ Z-axis cable management	SC-SC : Self-standing cable

\* The above explains the Models/Specifications chart to the left.

**Options**

Please add the option codes at the end of each stroke of the axis. When adding multiple options, put together in alphabetic order.

Name	Code	Page
AQ seal	AQ	→P13
Brake	B	→P13
Creep sensor	C	→P13
Home limit switch	L	→P14
Reversed-home specification	NM	→P14
Guide with ball-retaining mechanism	RT	→P14

**Configuration Direction**

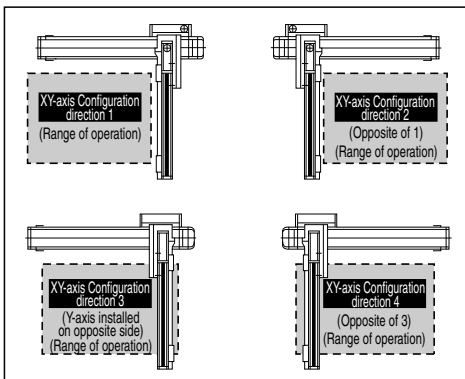

**Common Specifications**

\* [ ] is for the high-precision specification.

Drive system	Ball screw, rolled C10 [equivalent to rolled C5]
Positioning repeatability	±0.02mm [±0.01mm]
Backlash	0.05mm or less [0.02mm or less]
Guide	Integrated with base
Base	Material: Aluminum with white alumite treatment
X-axis motor output / lead	200W / 20mm
Y-axis motor output / lead	100W / 20mm
Z-axis motor output / lead	60W / 8mm (M), 4mm (L)

**Applicable Controller Specifications**

Refer to page 65 for System Configuration.

**Axis Configuration**

\* [ ] is for the high-precision specification.

Axis Type	Model	Page
X-axis	ISA[ISPA]-MXM- <input type="checkbox"/> -200-20-(Stroke)-T1	→P19
Y-axis	ISA[ISPA]-MYM- <input type="checkbox"/> -100-20-(Stroke)-T1	→P21
Z-axis	ISA[ISPA]-SZM- <input type="checkbox"/> -60-8/4-(Stroke)-T1-B-NM	→P17

\*In the above model name,  indicates encoder type A (absolute) or I (incremental).

**Caution**

(Note 1) The stroke in the model is specified in cm (centimeters).  
 (Note 2) The cable length measures from the X-axis connector box to the controller. The standard lengths are 3m and 5m, but other lengths can also be specified in meters. The maximum length is 20m.  
 (Note 3) The rated acceleration is 0.3G. Increasing the acceleration will result in lower load capacity.  
 (Note 4) Please note that a longer stroke will result in a lower maximum speed.

\* For other points to note, please refer to page 49.

ICSA3 [ICSPA3] -BC□HS1□

Load Capacity (kg) (Note3)

BC□HS1M

		Y-axis stroke			
		100	200	300	400
Z-axis stroke	100	3.0			
	200	2.3			
	300	1.6			

BC□HS1L

		Y-axis stroke			
		100	200	300	400
Z-axis stroke	100	11.0			
	200	10.3			
	300	9.6			

Maximum Speed by Stroke (mm/sec) (Note4)

BC□HS1M

		Stroke							
		100	200	300	400	500	600	700	800
X-axis	-	1000							795
Y-axis	1000		-	-	-	-	-	-	
Z-axis	400	-	-	-	-	-	-	-	

BC□HS1L

		Stroke							
		100	200	300	400	500	600	700	800
X-axis	-	1000							795
Y-axis	1000		-	-	-	-	-	-	
Z-axis	200	-	-	-	-	-	-	-	

Dimensions

\* The dimension below is for XY-axis Configuration direction 1.

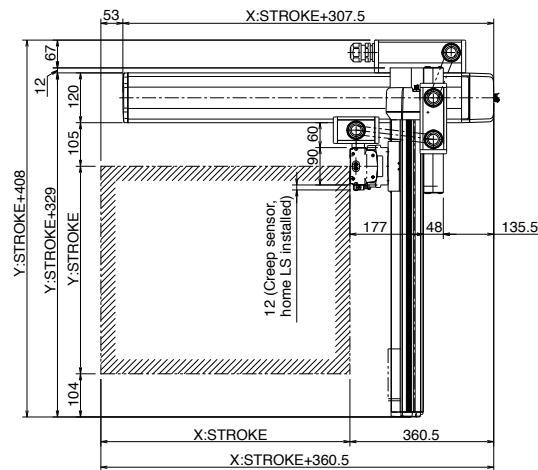
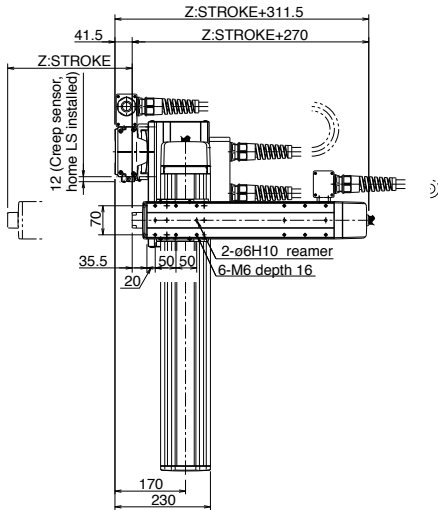

\* The configuration position in the figure is home position. To change the home position, indicate NM in the option. Note that changing the home direction will require the actuator to be returned to IAI for adjustment.

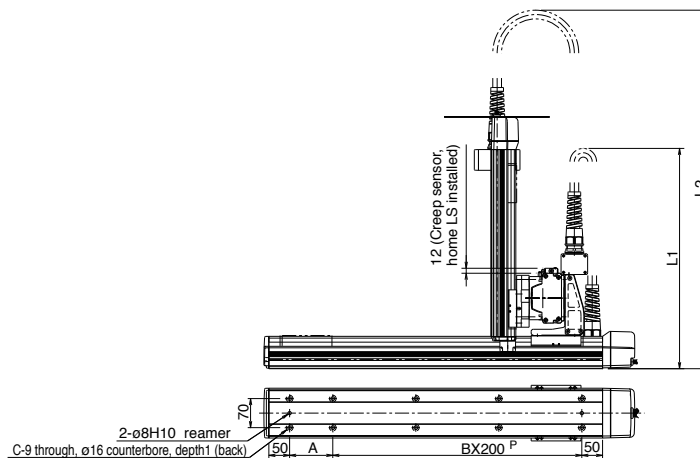

X stroke	200	300	400	500	600	700	800
L1	(550)	(600)	(650)	(700)	(750)	(800)	(850)
A	104	204	104	204	104	204	104
B	1	1	2	2	3	3	4
C	6	6	8	8	10	10	12

		Y stroke				
		100	200	300	400	500
Z stroke	100	(630)	(680)	(730)	(780)	(830)
	200	(730)	(780)	(830)	(880)	(930)
	300	(830)	(880)	(930)	(980)	(1030)

**ICSA3-BC HS3M** Cartesian Robot: X-Y-Z 3-Axes Configuration  
Z-Axis Slider Mount Type

**ICSPA3-BC HS3M** Cartesian Robot: X-Y-Z 3-Axes Configuration  
Z-Axis Slider Mount Type **High-Precision Specification**

Type XYB + Z-Axis Slider Mount Type Stroke X-axis: 200-800mm Y-axis: 100-500mm Z-axis: 100-300mm Load capacity 10kg - 6.7kg

Model specification items Series Type Encoder type X-axis stroke + options Y-axis stroke + options Z-axis stroke + options Applicable controller Cable length Cable management  
(Example) ICSA3 (ICSPA3) - BC1HS3M - A - 70AQL - 40AQL - 30BLNM - T1 - 5L - SC - SC



\* Refer to page 51 for the details of model specification items.

**Models/Specifications** \* [ ] is for the high-precision specification.

Encoder Type	XY-axis configuration direction (*1)	Z-axis type (*2)	Model
Absolute	1	M	ICSA3 [ICSPA3] -BC1HS3M-A- [1] - [2] - [3] -BNM-T1- [4] - [5]
	2	M	ICSA3 [ICSPA3] -BC2HS3M-A- [1] - [2] - [3] -BNM-T1- [4] - [5]
	3	M	ICSA3 [ICSPA3] -BC3HS3M-A- [1] - [2] - [3] -BNM-T1- [4] - [5]
	4	M	ICSA3 [ICSPA3] -BC4HS3M-A- [1] - [2] - [3] -BNM-T1- [4] - [5]
Incremental	1	M	ICSA3 [ICSPA3] -BC1HS3M-I- [1] - [2] - [3] -BNM-T1- [4] - [5]
	2	M	ICSA3 [ICSPA3] -BC2HS3M-I- [1] - [2] - [3] -BNM-T1- [4] - [5]
	3	M	ICSA3 [ICSPA3] -BC3HS3M-I- [1] - [2] - [3] -BNM-T1- [4] - [5]
	4	M	ICSA3 [ICSPA3] -BC4HS3M-I- [1] - [2] - [3] -BNM-T1- [4] - [5]

\*1: Refer to the figure below for XY-axis configuration direction.  
\*2: The load capacity and the maximum speed may vary depending on the type of Z-axis.  
Note: T1 in the above models will be T2 when operated with XSEL-P/Q type.

**Explanation of Model Code**

Number	Contents	Specification
[1]	X-axis stroke (Note 1)	20 : 80mm ~ 80 : 800mm
[2]	Y-axis stroke (Note 1)	10 : 100mm ~ 50 : 500mm
[3]	Z-axis stroke (Note 1)	10 : 100mm ~ 30 : 300mm
[4]	Cable length (Note 2)	3L : 3m 5L : 5m
[5]	Y-axis/ Z-axis cable management	SC-SC : Self-standing cable

\* The above explains the Models/Specifications chart to the left.

**Options**

Please add the option codes at the end of each stroke of the axis.  
When adding multiple options, put together in alphabetic order.

Name	Code	Page
AQ seal	AQ	→P13
Brake	B	→P13
Creep sensor	C	→P13
Home limit switch	L	→P14
Reversed-home specification	NM	→P14
Guide with ball-retaining mechanism	RT	→P14

**Configuration Direction**

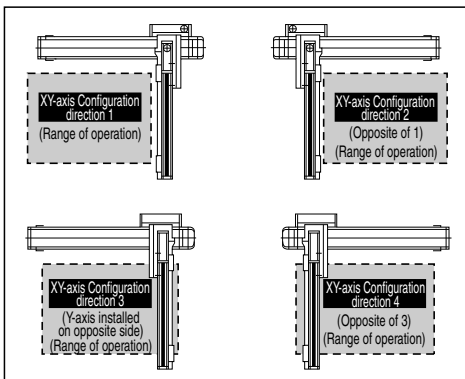

**Common Specifications** \* [ ] is for the high-precision specification.

Drive system	Ball screw, rolled C10 [equivalent to rolled C5]
Positioning repeatability	±0.02mm [±0.01mm]
Backlash	0.05mm or less [0.02mm or less]
Guide	Integrated with base
Base	Material: Aluminum with white alumite treatment
X-axis motor output / lead	200W / 20mm
Y-axis motor output / lead	100W / 20mm
Z-axis motor output / lead	200W / 10mm

**Applicable Controller Specifications**

Refer to page 65 for System Configuration.

**Axis Configuration** \* [ ] is for the high-precision specification.

Axis Type	Model	Page
X-axis	ISA[ISPA]-MXM-□-200-20-(Stroke)-T1	→P19
Y-axis	ISA[ISPA]-MYM-□-100-20-(Stroke)-T1	→P21
Z-axis	ISA[ISPA]-MZM-□-200-10-(Stroke)-T1-B-NM	→P24

\*In the above model name, □ indicates encoder type A (absolute) or I (incremental).

**Caution**

(Note 1) The stroke in the model is specified in cm (centimeters).  
(Note 2) The cable length measures from the X-axis connector box to the controller. The standard lengths are 3m and 5m, but other lengths can also be specified in meters. The maximum length is 20m.  
(Note 3) The rated acceleration is 0.3G. Increasing the acceleration will result in lower load capacity.  
(Note 4) Please note that a longer stroke will result in a lower maximum speed.

\* For other points to note, please refer to page 49.

**ICSA3 [ICSPA3] -BC□HS3M**

**Load Capacity (kg) (Note3)**

**BC□HS3M**

		Y-axis stroke				
		100	200	300	400	500
Z-axis stroke	100	10.0				8.7
	200	9.0				7.7
	300	8.0				6.7

**Maximum Speed by Stroke (mm/sec) (Note4)**

**BC□HS3M**

	Stroke								
	100	200	300	400	500	600	700	800	
X-axis	-	1000						-	795
Y-axis	1000				-	-	-	-	-
Z-axis	500		-	-	-	-	-	-	

**Dimensions**

\* The dimension below is for XY-axis Configuration direction 1.

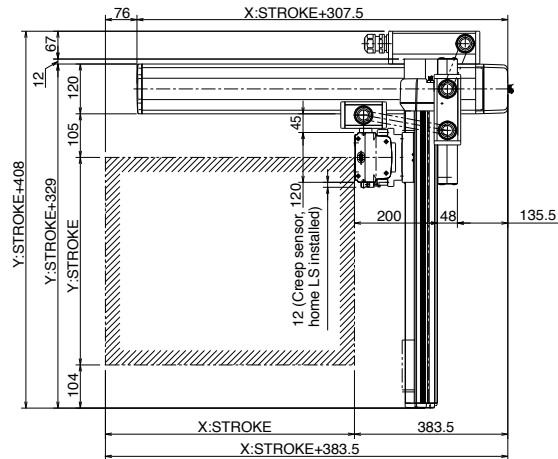
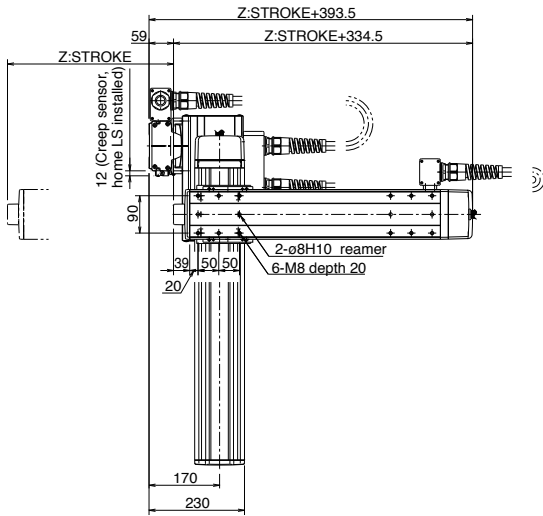

\* The configuration position in the figure is home position. To change the home position, indicate NM in the option. Note that changing the home direction will require the actuator to be returned to IAI for adjustment.

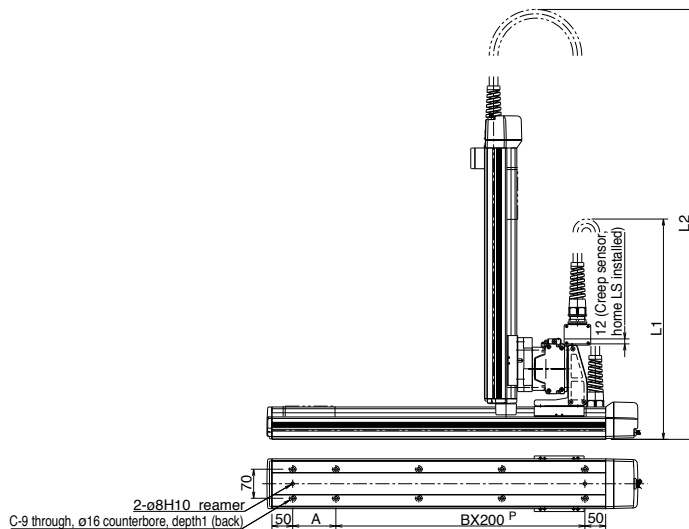

X stroke	200	300	400	500	600	700	800
L1	(550)	(600)	(650)	(700)	(750)	(800)	(850)
A	104	204	104	204	104	204	104
B	1	1	2	2	3	3	4
C	6	6	8	8	10	10	12

		Y stroke				
		100	200	300	400	500
Z stroke	100	(670)	(720)	(770)	(820)	(870)
	200	(770)	(820)	(870)	(920)	(970)
	300	(870)	(920)	(970)	(1020)	(1070)
	400	(970)	(1020)	(1070)	(1120)	(1170)

<b>ICSA3-BC</b> <input type="checkbox"/> <b>MS1</b> <input type="checkbox"/>		Cartesian Robot: X-Y-Z 3-Axes Configuration Z-Axis Slider Mount Type	
<b>ICSPA3-BC</b> <input type="checkbox"/> <b>MS1</b> <input type="checkbox"/>		Cartesian Robot: X-Y-Z 3-Axes Configuration Z-Axis Slider Mount Type <b>High-Precision Specification</b>	
Type	XYB + Z-Axis Slider Mount Type	Stroke	X-axis: 200-800mm Y-axis: 100-500mm Z-axis: 100-300mm
Load capacity	11kg - 1.6kg		
Model specification items	Series	Type	Encoder type
(Example)	ICSA3 (ICSPA3)	-BC1MS1M-	A
			- 70AQL - 40AQL - 30BLNM - T1 - 5L - SC - SC



\* Refer to page 51 for the details of model specification items.

**Models/Specifications**

\* [ ] is for the high-precision specification.

Encoder Type	XY-axis configuration direction (*1)	Z-axis type (*2)	Model
Absolute	1	M	ICSA3 [ICSPA3] -BC1MS1M-A- <input type="checkbox"/> - <input type="checkbox"/> - <input type="checkbox"/> -BNM-T1- <input type="checkbox"/> - <input type="checkbox"/>
		L	ICSA3 [ICSPA3] -BC1MS1L-A- <input type="checkbox"/> - <input type="checkbox"/> - <input type="checkbox"/> -BNM-T1- <input type="checkbox"/> - <input type="checkbox"/>
	2	M	ICSA3 [ICSPA3] -BC2MS1M-A- <input type="checkbox"/> - <input type="checkbox"/> - <input type="checkbox"/> -BNM-T1- <input type="checkbox"/> - <input type="checkbox"/>
		L	ICSA3 [ICSPA3] -BC2MS1L-A- <input type="checkbox"/> - <input type="checkbox"/> - <input type="checkbox"/> -BNM-T1- <input type="checkbox"/> - <input type="checkbox"/>
	3	M	ICSA3 [ICSPA3] -BC3MS1M-A- <input type="checkbox"/> - <input type="checkbox"/> - <input type="checkbox"/> -BNM-T1- <input type="checkbox"/> - <input type="checkbox"/>
		L	ICSA3 [ICSPA3] -BC3MS1L-A- <input type="checkbox"/> - <input type="checkbox"/> - <input type="checkbox"/> -BNM-T1- <input type="checkbox"/> - <input type="checkbox"/>
4	M	ICSA3 [ICSPA3] -BC4MS1M-A- <input type="checkbox"/> - <input type="checkbox"/> - <input type="checkbox"/> -BNM-T1- <input type="checkbox"/> - <input type="checkbox"/>	
	L	ICSA3 [ICSPA3] -BC4MS1L-A- <input type="checkbox"/> - <input type="checkbox"/> - <input type="checkbox"/> -BNM-T1- <input type="checkbox"/> - <input type="checkbox"/>	
Incremental	1	M	ICSA3 [ICSPA3] -BC1MS1M-I- <input type="checkbox"/> - <input type="checkbox"/> - <input type="checkbox"/> -BNM-T1- <input type="checkbox"/> - <input type="checkbox"/>
		L	ICSA3 [ICSPA3] -BC1MS1L-I- <input type="checkbox"/> - <input type="checkbox"/> - <input type="checkbox"/> -BNM-T1- <input type="checkbox"/> - <input type="checkbox"/>
	2	M	ICSA3 [ICSPA3] -BC2MS1M-I- <input type="checkbox"/> - <input type="checkbox"/> - <input type="checkbox"/> -BNM-T1- <input type="checkbox"/> - <input type="checkbox"/>
		L	ICSA3 [ICSPA3] -BC2MS1L-I- <input type="checkbox"/> - <input type="checkbox"/> - <input type="checkbox"/> -BNM-T1- <input type="checkbox"/> - <input type="checkbox"/>
	3	M	ICSA3 [ICSPA3] -BC3MS1M-I- <input type="checkbox"/> - <input type="checkbox"/> - <input type="checkbox"/> -BNM-T1- <input type="checkbox"/> - <input type="checkbox"/>
		L	ICSA3 [ICSPA3] -BC3MS1L-I- <input type="checkbox"/> - <input type="checkbox"/> - <input type="checkbox"/> -BNM-T1- <input type="checkbox"/> - <input type="checkbox"/>
	4	M	ICSA3 [ICSPA3] -BC4MS1M-I- <input type="checkbox"/> - <input type="checkbox"/> - <input type="checkbox"/> -BNM-T1- <input type="checkbox"/> - <input type="checkbox"/>
		L	ICSA3 [ICSPA3] -BC4MS1L-I- <input type="checkbox"/> - <input type="checkbox"/> - <input type="checkbox"/> -BNM-T1- <input type="checkbox"/> - <input type="checkbox"/>

\*1: Refer to the figure below for XY-axis configuration direction.  
 \*2: The load capacity and the maximum speed may vary depending on the type of Z-axis.  
 Note: T1 in the above models will be T2 when operated with XSEL-P/Q type.

**Explanation of Model Code**

Number	Contents	Specification
<input type="checkbox"/>	X-axis stroke (Note 1)	20 : 200mm ~ 80 : 800mm
<input type="checkbox"/>	Y-axis stroke (Note 1)	10 : 100mm ~ 50 : 500mm
<input type="checkbox"/>	Z-axis stroke (Note 1)	10 : 100mm ~ 30 : 300mm
<input type="checkbox"/>	Cable length (Note 2)	3L : 3m 5L : 5m
<input type="checkbox"/>	Y-axis/ Z-axis cable management	SC-SC : Self-standing cable

\* The above explains the Models/Specifications chart to the left.

**Options**

Please add the option codes at the end of each stroke of the axis.  
 When adding multiple options, put together in alphabetic order.

Name	Code	Page
AQ seal	AQ	→P13
Brake	B	→P13
Creep sensor	C	→P13
Home limit switch	L	→P14
Reversed-home specification	NM	→P14
Guide with ball-retaining mechanism	RT	→P14

**Configuration Direction**

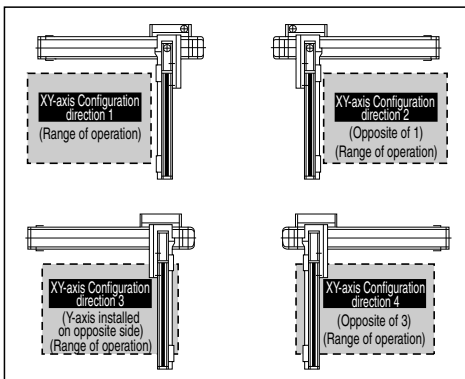

**Common Specifications**

\* [ ] is for the high-precision specification.

Drive system	Ball screw, rolled C10 [equivalent to rolled C5]
Positioning repeatability	±0.02mm [±0.01mm]
Backlash	0.05mm or less [0.02mm or less]
Guide	Integrated with base
Base	Material: Aluminum with white alumite treatment
X-axis motor output / lead	100W / 10mm
Y-axis motor output / lead	100W / 10mm
Z-axis motor output / lead	60W / 8mm (M), 4mm (L)

**Applicable Controller Specifications**

Refer to page 65 for System Configuration.

**Axis Configuration**

\* [ ] is for the high-precision specification.

Axis Type	Model	Page
X-axis	ISA[ISPA]-MXM- <input type="checkbox"/> -100-10-(Stroke)-T1	→P18
Y-axis	ISA[ISPA]-MYM- <input type="checkbox"/> -100-10-(Stroke)-T1	→P21
Z-axis	ISA[ISPA]-SZM- <input type="checkbox"/> -60-8/4-(Stroke)-T1-B-NM	→P17

\*In the above model name,  indicates encoder type A (absolute) or I (incremental).

**Caution**

(Note 1) The stroke in the model is specified in cm (centimeters).  
 (Note 2) The cable length measures from the X-axis connector box to the controller. The standard lengths are 3m and 5m, but other lengths can also be specified in meters. The maximum length is 20m.  
 (Note 3) The rated acceleration is 0.3G. Increasing the acceleration will result in lower load capacity.  
 (Note 4) Please note that a longer stroke will result in a lower maximum speed.

\* For other points to note, please refer to page 49.



ICSA3 [ICSPA3] - BC□MS1□

**Load Capacity (kg) (Note3)**

**BC□MS1M**

		Y-axis stroke			
		100	200	300	400
Z-axis stroke	100	3.0			
	200	2.3			
	300	1.6			

**BC□MS1L**

		Y-axis stroke			
		100	200	300	400
Z-axis stroke	100	11.0			
	200	10.3			
	300	9.6			

**Maximum Speed by Stroke (mm/sec) (Note4)**

**BC□MS1M**

	Stroke								
	100	200	300	400	500	600	700	800	
X-axis	-	500					480	380	
Y-axis	500				-	-	-		
Z-axis	400			-	-	-	-		

**BC□MS1L**

	Stroke								
	100	200	300	400	500	600	700	800	
X-axis	-	500					480	380	
Y-axis	500				-	-	-		
Z-axis	200			-	-	-	-		

**Dimensions**

\* The dimension below is for XY-axis Configuration direction 1.

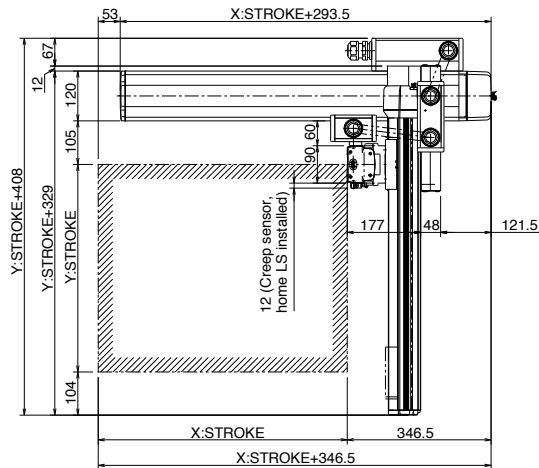
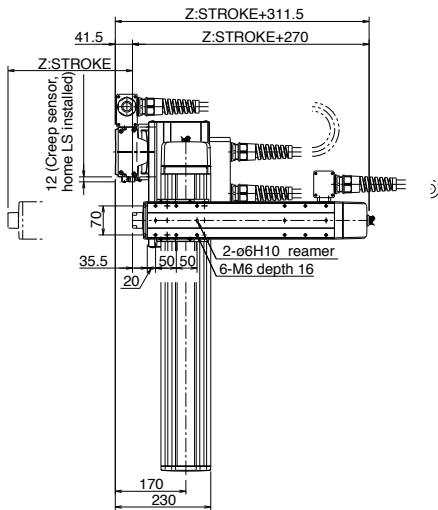

\* The configuration position in the figure is home position. To change the home position, indicate NM in the option. Note that changing the home direction will require the actuator to be returned to IAI for adjustment.

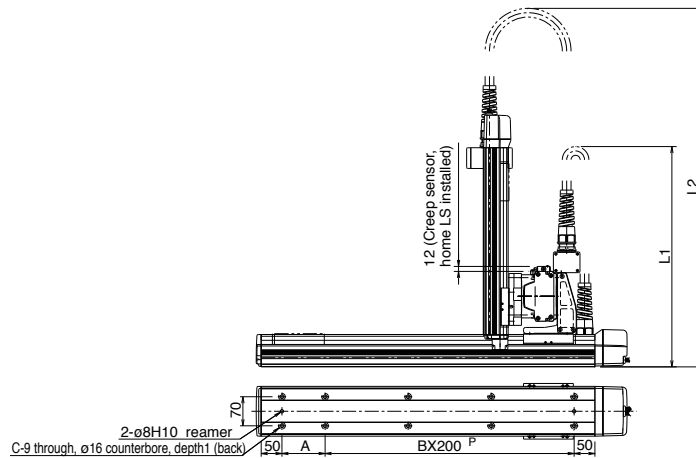

X stroke	200	300	400	500	600	700	800
L1	(550)	(600)	(650)	(700)	(750)	(800)	(850)
A	104	204	104	204	104	204	104
B	1	1	2	2	3	3	4
C	6	6	8	8	10	10	12

		Y stroke				
		100	200	300	400	500
Z stroke	100	(630)	(680)	(730)	(780)	(830)
	200	(730)	(780)	(830)	(880)	(930)
	300	(830)	(880)	(930)	(980)	(1030)

<b>ICSA3-BC</b>		<b>MS3M</b>		Cartesian Robot: X-Y-Z 3-Axes Configuration Z-Axis Slider Mount Type					
<b>ICSPA3-BC</b>		<b>MS3M</b>		Cartesian Robot: X-Y-Z 3-Axes Configuration Z-Axis Slider Mount Type <b>High-Precision Specification</b>					
Type	XYB + Z-Axis Slider Mount Type	Stroke	X-axis: 200-800mm Y-axis: 100-500mm Z-axis: 100-300mm	Load capacity	11.9kg - 6.7kg				
Model specification items	Series	Type	Encoder type	X-axis stroke + options	Y-axis stroke + options	Z-axis stroke + options	Applicable controller	Cable length	Cable management
(Example)	ICSA3 (ICSPA3)	-BC1MS3M-	A	- 70AQL	- 40AQL	- 30BLNM	- T1	- 5L	- SC - SC



\* Refer to page 51 for the details of model specification items.

**Models/Specifications**

\* [ ] is for the high-precision specification.

Encoder Type	XY-axis configuration direction (*1)	Z-axis type (*2)	Model
Absolute	1	M	ICSA3 [ICSPA3] -BC1MS3M-A-[1]-[2]-[3]-BNM-T1-[4]-[5]
	2	M	ICSA3 [ICSPA3] -BC2MS3M-A-[1]-[2]-[3]-BNM-T1-[4]-[5]
	3	M	ICSA3 [ICSPA3] -BC3MS3M-A-[1]-[2]-[3]-BNM-T1-[4]-[5]
	4	M	ICSA3 [ICSPA3] -BC4MS3M-A-[1]-[2]-[3]-BNM-T1-[4]-[5]
Incremental	1	M	ICSA3 [ICSPA3] -BC1MS3M-I-[1]-[2]-[3]-BNM-T1-[4]-[5]
	2	M	ICSA3 [ICSPA3] -BC2MS3M-I-[1]-[2]-[3]-BNM-T1-[4]-[5]
	3	M	ICSA3 [ICSPA3] -BC3MS3M-I-[1]-[2]-[3]-BNM-T1-[4]-[5]
	4	M	ICSA3 [ICSPA3] -BC4MS3M-I-[1]-[2]-[3]-BNM-T1-[4]-[5]

\*1: Refer to the figure below for XY-axis configuration direction.

\*2: The load capacity and the maximum speed may vary depending on the type of Z-axis.

Note: T1 in the above models will be T2 when operated with XSEL-P/Q type.

**Explanation of Model Code**

Number	Contents	Specification
①	X-axis stroke (Note 1)	20 : 200mm ~ 80 : 800mm
②	Y-axis stroke (Note 1)	10 : 100mm ~ 50 : 500mm
③	Z-axis stroke (Note 1)	10 : 100mm ~ 30 : 300mm
④	Cable length (Note 2)	3L : 3m 5L : 5m
⑤	Y-axis/ Z-axis cable management	SC-SC : Self-standing cable

\* The above explains the Models/Specifications chart to the left.

**Options**

Please add the option codes at the end of each stroke of the axis. When adding multiple options, put together in alphabetic order.

Name	Code	Page
AQ seal	AQ	→P13
Brake	B	→P13
Creep sensor	C	→P13
Home limit switch	L	→P14
Reversed-home specification	NM	→P14
Guide with ball-retaining mechanism	RT	→P14

**Configuration Direction**

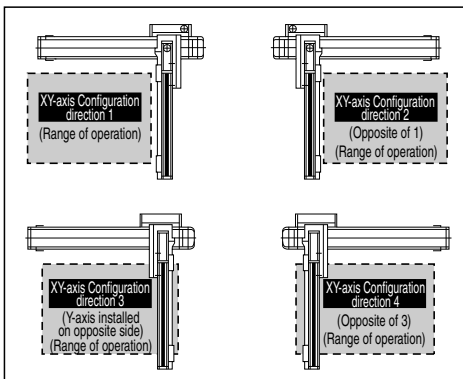

**Common Specifications**

\* [ ] is for the high-precision specification.

Drive system	Ball screw, rolled C10 [equivalent to rolled C5]
Positioning repeatability	±0.02mm [±0.01mm]
Backlash	0.05mm or less [0.02mm or less]
Guide	Integrated with base
Base	Material: Aluminum with white alumite treatment
X-axis motor output / lead	100W / 10mm
Y-axis motor output / lead	100W / 10mm
Z-axis motor output / lead	200W / 10mm (M)

**Applicable Controller Specifications**

Refer to page 65 for System Configuration.

**Axis Configuration**

\* [ ] is for the high-precision specification.

Axis Type	Model	Page
X-axis	ISA[ISPA]-MXM-□-100-10-(Stroke)-T1	→P18
Y-axis	ISA[ISPA]-MYM-□-100-10-(Stroke)-T1	→P21
Z-axis	ISA[ISPA]-MZM-□-200-10-(Stroke)-T1-B-NM	→P24

\*In the above model name, □ indicates encoder type A (absolute) or I (incremental).

**Caution**

(Note 1) The stroke in the model is specified in cm (centimeters).  
 (Note 2) The cable length measures from the X-axis connector box to the controller. The standard lengths are 3m and 5m, but other lengths can also be specified in meters. The maximum length is 20m.  
 (Note 3) The rated acceleration is 0.3G. Increasing the acceleration will result in lower load capacity.  
 (Note 4) Please note that a longer stroke will result in a lower maximum speed.

\* For other points to note, please refer to page 49.

**ICSA3 [ICSPA3] -BC□MS3M**

**Load Capacity (kg) (Note3)**

**BC□MS3M**

		Y-axis stroke				
		100	200	300	400	500
Z-axis stroke	100	11.9		11.8	8.7	
	200	10.9		10.8	7.7	
	300	9.9		9.8	6.7	

**Maximum Speed by Stroke (mm/sec) (Note4)**

**BC□MS3M**

	Stroke								
	100	200	300	400	500	600	700	800	
X-axis	-	500					480	380	
Y-axis	500				-	-	-		
Z-axis	500			-	-	-			

**Dimensions** \* The dimension below is for XY-axis Configuration direction 1.

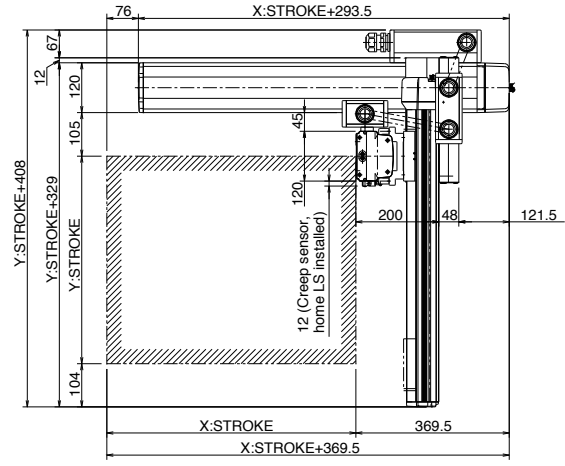
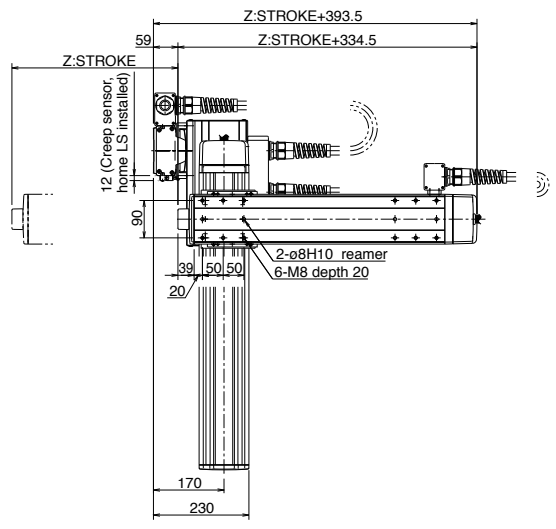

\* The configuration position in the figure is home position. To change the home position, indicate NM in the option. Note that changing the home direction will require the actuator to be returned to IAI for adjustment.

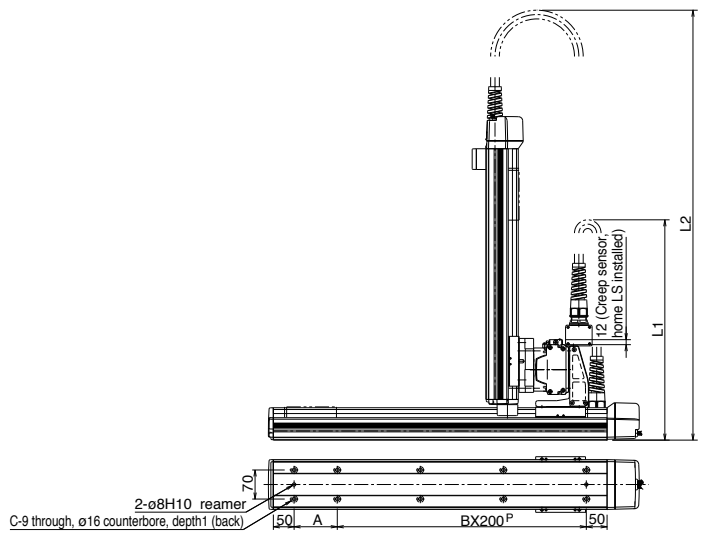

X stroke	200	300	400	500	600	700	800
L1	(550)	(600)	(650)	(700)	(750)	(800)	(850)
A	104	204	104	204	104	204	104
B	1	1	2	2	3	3	4
C	6	6	8	8	10	10	12

		Y stroke				
		100	200	300	400	500
Z stroke	100	(670)	(720)	(770)	(820)	(870)
	200	(770)	(820)	(870)	(920)	(970)
	300	(870)	(920)	(970)	(1020)	(1070)
	400	(970)	(1020)	(1070)	(1120)	(1170)

**ICSA3-BD□HS1□** Cartesian Robot: X-Y-Z 3-Axes Configuration  
Z-Axis Slider Mount Type

**ICSPA3-BD□HS1□** Cartesian Robot: X-Y-Z 3-Axes Configuration  
Z-Axis Slider Mount Type High-Precision Specification

Type XYB + Z-Axis Slider Mount Type Stroke X-axis: 800-2000mm Y-axis: 100-500mm Z-axis: 100-300mm Load capacity 11kg - 1.6kg

Model specification items Series Type Encoder type X-axis stroke + options Y-axis stroke + options Z-axis stroke + options Applicable controller Cable length Cable management  
(Example) ICSA3 (ICSPA3) - BD1HS1M - A - 100AQL - 40AQL - 30BLNM - T1 - 5L - CT - SC

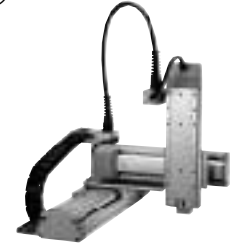

\* Refer to page 51 for the details of model specification items.

**Models/Specifications**

\* [ ] is for the high-precision specification.

Encoder Type	XY-axis configuration direction (*1)	Z-axis type (*2)	Model
Absolute	1	M	ICSA3 [ICSPA3] -BD1HS1M-A-①-②-③-BNM-T1-④-⑤
		L	ICSA3 [ICSPA3] -BD1HS1L-A-①-②-③-BNM-T1-④-⑤
	2	M	ICSA3 [ICSPA3] -BD2HS1M-A-①-②-③-BNM-T1-④-⑤
		L	ICSA3 [ICSPA3] -BD2HS1L-A-①-②-③-BNM-T1-④-⑤
	3	M	ICSA3 [ICSPA3] -BD3HS1M-A-①-②-③-BNM-T1-④-⑤
		L	ICSA3 [ICSPA3] -BD3HS1L-A-①-②-③-BNM-T1-④-⑤
4	M	ICSA3 [ICSPA3] -BD4HS1M-A-①-②-③-BNM-T1-④-⑤	
	L	ICSA3 [ICSPA3] -BD4HS1L-A-①-②-③-BNM-T1-④-⑤	
Incremental	1	M	ICSA3 [ICSPA3] -BD1HS1M-I-①-②-③-BNM-T1-④-⑤
		L	ICSA3 [ICSPA3] -BD1HS1L-I-①-②-③-BNM-T1-④-⑤
	2	M	ICSA3 [ICSPA3] -BD2HS1M-I-①-②-③-BNM-T1-④-⑤
		L	ICSA3 [ICSPA3] -BD2HS1L-I-①-②-③-BNM-T1-④-⑤
	3	M	ICSA3 [ICSPA3] -BD3HS1M-I-①-②-③-BNM-T1-④-⑤
		L	ICSA3 [ICSPA3] -BD3HS1L-I-①-②-③-BNM-T1-④-⑤
	4	M	ICSA3 [ICSPA3] -BD4HS1M-I-①-②-③-BNM-T1-④-⑤
		L	ICSA3 [ICSPA3] -BD4HS1L-I-①-②-③-BNM-T1-④-⑤

\*1: Refer to the figure below for XY-axis configuration direction.  
\*2: The load capacity and the maximum speed may vary depending on the type of Z-axis.  
Note: T1 in the above models will be T2 when operated with XSEL-P/Q type.

**Explanation of Model Code**

Number	Contents	Specification
①	X-axis stroke (Note 1)	80 : 800mm ~ 200 : 2000mm
②	Y-axis stroke (Note 1)	10 : 100mm ~ 50 : 500mm
③	Z-axis stroke (Note 1)	10 : 100mm ~ 30 : 300mm
④	Cable length (Note 2)	3L : 3m 5L : 5m
⑤	Y-axis/ Z-axis cable management	CT-SC : Self-standing cable (*3)

\* The above explains the Models/Specifications chart to the left.  
\*3 Only cable track can be specified for the Y-axis cable management with model # BD□HS1□.

**Options**

Please add the option codes at the end of each stroke of the axis.  
When adding multiple options, put together in alphabetic order.

Name	Code	Page
AQ seal	AQ	→P13
Brake	B	→P13
Creep sensor	C	→P13
Home limit switch	L	→P14
Reversed-home specification	NM	→P14
Guide with ball-retaining mechanism	RT	→P14

**Configuration Direction**

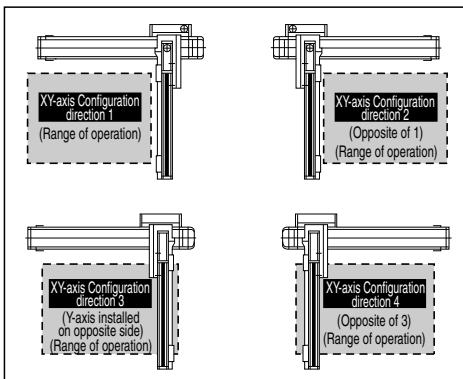

**Common Specifications**

\* [ ] is for the high-precision specification.

Drive system	Ball screw, rolled C10 [equivalent to rolled C5]
Positioning repeatability	±0.02mm [±0.01mm]
Backlash	0.05mm or less [0.02mm or less]
Guide	Integrated with base
Base	Material: Aluminum with white alumite treatment
X-axis motor output / lead	200W / 20mm
Y-axis motor output / lead	100W / 20mm
Z-axis motor output / lead	60W / 8mm (M), 4mm (L)

**Applicable Controller Specifications**

Refer to page 65 for System Configuration.

**Axis Configuration**

\* [ ] is for the high-precision specification.

Axis Type	Model	Page
X-axis	ISA[ISPA]-MXMX-□-200-20-(Stroke)-T1	→P20
Y-axis	ISA[ISPA]-MYM-□-100-20-(Stroke)-T1	→P21
Z-axis	ISA[ISPA]-SZM-□-60-8/4-(Stroke)-T1-B-NM	→P17

\*In the above model name, □ indicates encoder type A (absolute) or I (incremental).

**Caution**

(Note 1) The stroke in the model is specified in cm (centimeters).  
(Note 2) The cable length measures from the X-axis connector box to the controller. The standard lengths are 3m and 5m, but other lengths can also be specified in meters. The maximum length is 20m.  
(Note 3) The rated acceleration is 0.3G. Increasing the acceleration will result in lower load capacity.  
(Note 4) Please note that a longer stroke will result in a lower maximum speed.

\* For other points to note, please refer to page 49.

ICSA3 [ICSPA3] -BD□HS1□

Single-Axis Robots

Cartesian Robots

Controllers

**Load Capacity (kg) (Note3)**

■BD□HS1M

		Y-axis stroke				
		100	200	300	400	500
Z-axis stroke	100	3.0				
	200	2.3				
	300	1.6				

■BD□HS1L

		Y-axis stroke				
		100	200	300	400	500
Z-axis stroke	100	11.0				
	200	10.3				
	300	9.6				

**Maximum Speed by Stroke (mm/sec) (Note4)**

■BD□HS1M

	Stroke									
	100 ~ 400	500	800 ~ 1300	1400	1500	1600	1700	1800	1900	2000
X-axis	-	-	1000	950	800	700	600	550	500	450
Y-axis	1000		-	-	-	-	-	-	-	-
Z-axis	400	-	-	-	-	-	-	-	-	-

■BD□HS1L

	Stroke									
	100 ~ 400	500	800 ~ 1300	1400	1500	1600	1700	1800	1900	2000
X-axis	-	-	1000	950	800	700	600	550	500	450
Y-axis	1000		-	-	-	-	-	-	-	-
Z-axis	200	-	-	-	-	-	-	-	-	-

**Dimensions**

\* The dimension below is for XY-axis Configuration direction 1.

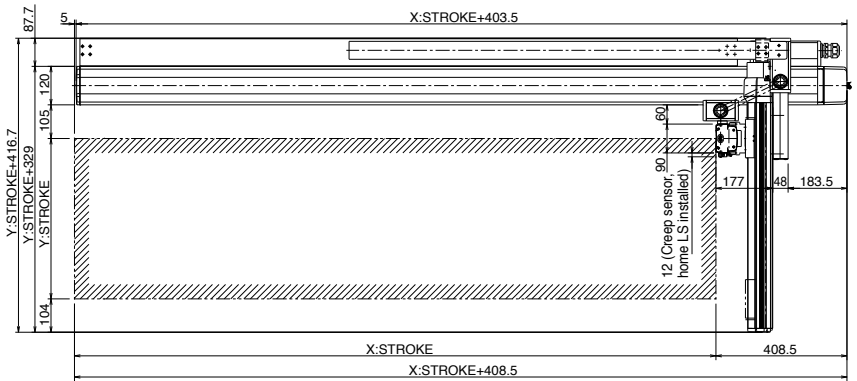
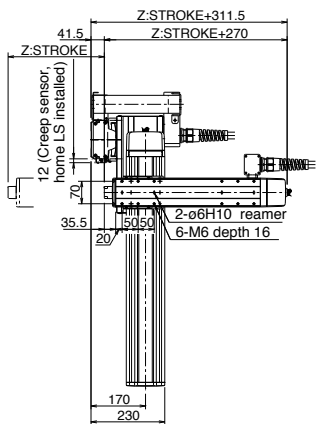

\* The configuration position in the figure is home position. To change the home position, indicate NM in the option. Note that changing the home direction will require the actuator to be returned to IAI for adjustment.

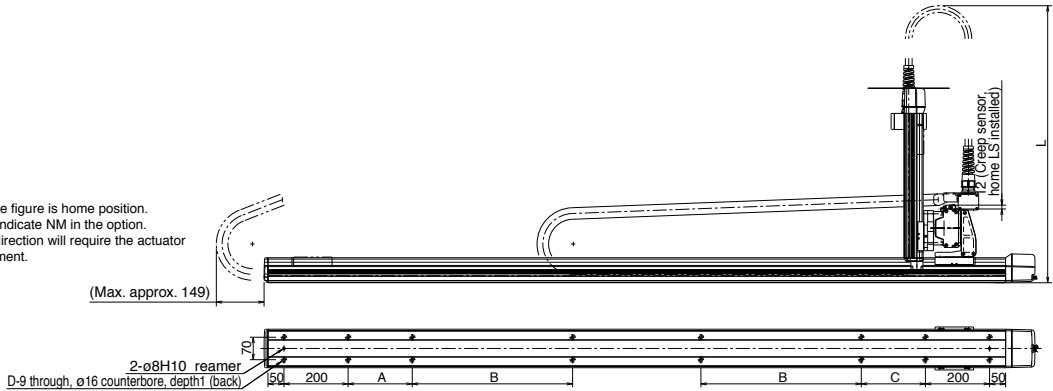

X st	800	900	1000	1100	1200	1300	1400	1500	1600	1700	1800	1900	2000
A	0	0	200	250	300	350	400	450	500	550	200	200	200
B	0	0	0	0	0	0	0	0	0	0	400	450	500
C	200	200	200	250	300	350	400	450	500	550	200	200	200
D	10	10	12	12	12	12	12	12	12	12	16	16	16

		Y stroke				
		100	200	300	400	500
Z stroke	100	(630)	(680)	(730)	(780)	(830)
	200	(730)	(780)	(830)	(880)	(930)
	300	(830)	(880)	(930)	(980)	(1030)

**ICSA3-BD□HS3M** Cartesian Robot: X-Y-Z 3-Axes Configuration  
Z-Axis Slider Mount Type

**ICSPA3-BD□HS3M** Cartesian Robot: X-Y-Z 3-Axes Configuration  
Z-Axis Slider Mount Type **High-Precision Specification**

Type XYB + Z-Axis Slider Mount Type Stroke X-axis: 800-2000mm Y-axis: 100-500mm Z-axis: 100-300mm Load capacity 10kg - 6.7kg

Model specification items	Series	Type	Encoder type	X-axis stroke + options	Y-axis stroke + options	Z-axis stroke + options	Applicable controller	Cable length	Cable management
(Example)	ICSA3 (ICSPA3)	-BD1MS3M-	A	- 100AQL	- 40AQL	- 30BLNM	- T1	- 5L	- CT - SC

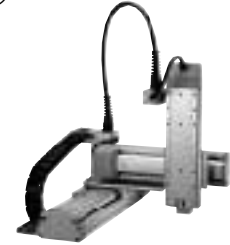

\* Refer to page 51 for the details of model specification items.

**Models/Specifications**

\* [ ] is for the high-precision specification.

Encoder Type	XY-axis configuration direction (*1)	Z-axis type (*2)	Model
Absolute	1	M	ICSA3 [ICSPA3] -BD1HS3M-A-①-②-③-BNM-T1-④-⑤
	2	M	ICSA3 [ICSPA3] -BD2HS3M-A-①-②-③-BNM-T1-④-⑤
	3	M	ICSA3 [ICSPA3] -BD3HS3M-A-①-②-③-BNM-T1-④-⑤
	4	M	ICSA3 [ICSPA3] -BD4HS3M-A-①-②-③-BNM-T1-④-⑤
Incremental	1	M	ICSA3 [ICSPA3] -BD1HS3M-I-①-②-③-BNM-T1-④-⑤
	2	M	ICSA3 [ICSPA3] -BD2HS3M-I-①-②-③-BNM-T1-④-⑤
	3	M	ICSA3 [ICSPA3] -BD3HS3M-I-①-②-③-BNM-T1-④-⑤
	4	M	ICSA3 [ICSPA3] -BD4HS3M-I-①-②-③-BNM-T1-④-⑤

\*1: Refer to the figure below for XY-axis configuration direction.

\*2: The load capacity and the maximum speed may vary depending on the type of Z-axis.

Note: T1 in the above models will be T2 when operated with XSEL-P/Q type.

**Explanation of Model Code**

Number	Contents	Specification
①	X-axis stroke (Note 1)	80 : 800mm ~ 200 : 2000mm
②	Y-axis stroke (Note 1)	10 : 100mm ~ 50 : 500mm
③	Z-axis stroke (Note 1)	10 : 100mm ~ 30 : 300mm
④	Cable length (Note 2)	3L : 3m 5L : 5m
⑤	Y-axis/ Z-axis cable management	SC-SC : Self-standing cable (*3)

\* The above explains the Models/Specifications chart to the left.

\*3 Only cable track can be specified for the Y-axis cable management with model # BD□HS3□.

**Options**

Please add the option codes at the end of each stroke of the axis. When adding multiple options, put together in alphabetic order.

Name	Code	Page
AQ seal	AQ	→P13
Brake	B	→P13
Creep sensor	C	→P13
Home limit switch	L	→P14
Reversed-home specification	NM	→P14
Guide with ball-retaining mechanism	RT	→P14

**Configuration Direction**

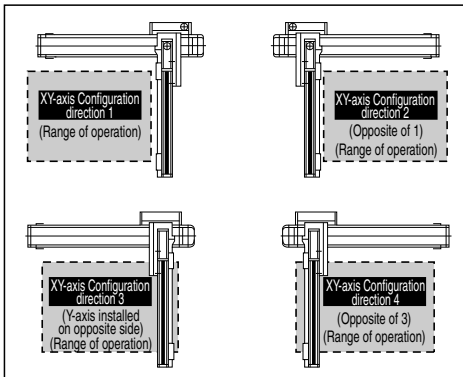

**Common Specifications**

\* [ ] is for the high-precision specification.

Drive system	Ball screw, rolled C10 [equivalent to rolled C5]
Positioning repeatability	±0.02mm [±0.01mm]
Backlash	0.05mm or less [0.02mm or less]
Guide	Integrated with base
Base	Material: Aluminum with white alumite treatment
X-axis motor output / lead	200W / 20mm
X-axis motor output / lead	100W / 20mm
X-axis motor output / lead	200W / 10mm (M)

**Applicable Controller Specifications**

Refer to page 65 for System Configuration.

**Axis Configuration**

\* [ ] is for the high-precision specification.

Axis Type	Model	Page
X-axis	ISA[ISPA]-MXMX-□-200-20-(Stroke)-T1	→P20
Y-axis	ISA[ISPA]-MYM-□-100-20-(Stroke)-T1	→P21
Z-axis	ISA[ISPA]-MZM-□-200-10-(Stroke)-T1-B-NM	→P24

\*In the above model name, □ indicates encoder type A (absolute) or I (incremental).

**Caution**

(Note 1) The stroke in the model is specified in cm (centimeters).  
 (Note 2) The cable length measures from the X-axis connector box to the controller. The standard lengths are 3m and 5m, but other lengths can also be specified in meters. The maximum length is 20m.  
 (Note 3) The rated acceleration is 0.3G. Increasing the acceleration will result in lower load capacity.  
 (Note 4) Please note that a longer stroke will result in a lower maximum speed.

\* For other points to note, please refer to page 49.

**ICSA3 [ICSPA3] -BD□HS3M**

**Load Capacity (kg) (Note3)**

**BD□HS3M**

		Y-axis stroke				
		100	200	300	400	500
Z-axis stroke	100	10.0				8.7
	200	9.0				7.7
	300	8.0				6.7

**Maximum Speed by Stroke (mm/sec) (Note4)**

**BD□HS3M**

	Stroke									
	100 ~ 300	400 ~ 500	800 ~ 1300	1400	1500	1600	1700	1800	1900	2000
X-axis	-	-	1000	950	800	700	600	550	500	450
Y-axis	1000		-	-	-	-	-	-	-	-
Z-axis	500	-	-	-	-	-	-	-	-	-

**Dimensions**

\* The dimension below is for XY-axis Configuration direction 1.

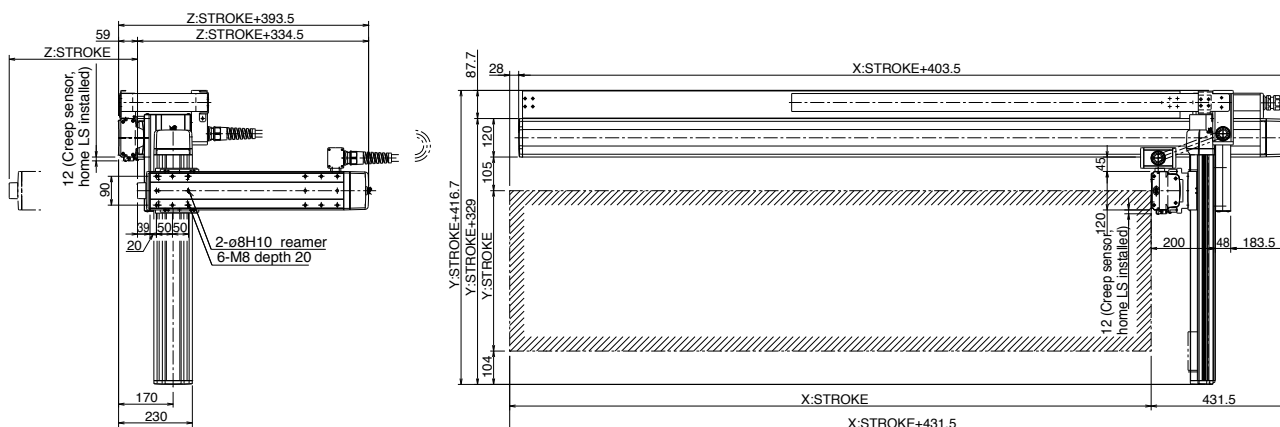

\* The configuration position in the figure is home position. To change the home position, indicate NM in the option. Note that changing the home direction will require the actuator to be returned to IAI for adjustment.

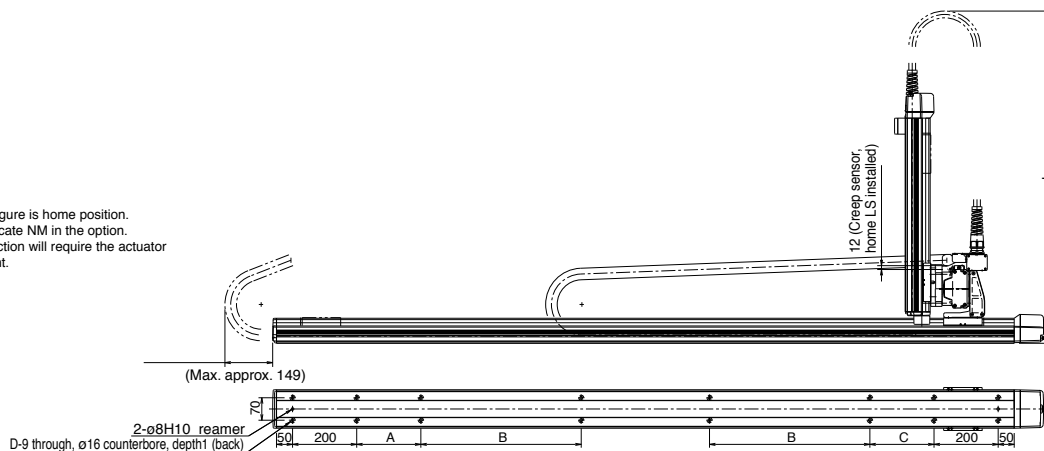

X st	800	900	1000	1100	1200	1300	1400	1500	1600	1700	1800	1900	2000
A	0	0	200	250	300	350	400	450	500	550	200	200	200
B	0	0	0	0	0	0	0	0	0	0	400	450	500
C	200	200	200	250	300	350	400	450	500	550	200	200	200
D	10	10	12	12	12	12	12	12	12	12	16	16	16

		Y stroke				
		100	200	300	400	500
Z stroke	100	(670)	(720)	(770)	(820)	(870)
	200	(770)	(820)	(870)	(920)	(970)
	300	(870)	(920)	(970)	(1020)	(1070)
	400	(970)	(1020)	(1070)	(1120)	(1170)

<b>ICSA3-BE</b> <input type="checkbox"/> <b>HS1</b> <input type="checkbox"/>		Cartesian Robot: X-Y-Z 3-Axes Configuration Z-Axis Slider Mount Type	
<b>ICSPA3-BE</b> <input type="checkbox"/> <b>HS1</b> <input type="checkbox"/>		Cartesian Robot: X-Y-Z 3-Axes Configuration Z-Axis Slider Mount Type <b>High-Precision Specification</b>	
Type	XYB + Z-Axis Slider Mount Type	Stroke	X-axis: 300~1000mm Y-axis: 200~700mm Z-axis: 100~400mm
Load capacity	11kg ~ 0.9kg		
Model specification items	Series	Type	Encoder type
(Example)	ICSA3 (ICSPA3)	-BE1HS1M-	A
			- 50AQL - 40AQL - 30BLNM - T1 - 5L - SC - SC



\* Refer to page 51 for the details of model specification items.

**Models/Specifications** \* [ ] is for the high-precision specification.

Encoder Type	XY-axis configuration direction (*1)	Z-axis type (*2)	Model
Absolute	1	M	ICSA3 [ICSPA3] -BE1HS1M-A- <input type="checkbox"/> - <input type="checkbox"/> - <input type="checkbox"/> - <input type="checkbox"/> -BNM-T1- <input type="checkbox"/> - <input type="checkbox"/>
		L	ICSA3 [ICSPA3] -BE1HS1L-A- <input type="checkbox"/> - <input type="checkbox"/> - <input type="checkbox"/> - <input type="checkbox"/> -BNM-T1- <input type="checkbox"/> - <input type="checkbox"/>
	2	M	ICSA3 [ICSPA3] -BE2HS1M-A- <input type="checkbox"/> - <input type="checkbox"/> - <input type="checkbox"/> - <input type="checkbox"/> -BNM-T1- <input type="checkbox"/> - <input type="checkbox"/>
		L	ICSA3 [ICSPA3] -BE2HS1L-A- <input type="checkbox"/> - <input type="checkbox"/> - <input type="checkbox"/> - <input type="checkbox"/> -BNM-T1- <input type="checkbox"/> - <input type="checkbox"/>
	3	M	ICSA3 [ICSPA3] -BE3HS1M-A- <input type="checkbox"/> - <input type="checkbox"/> - <input type="checkbox"/> - <input type="checkbox"/> -BNM-T1- <input type="checkbox"/> - <input type="checkbox"/>
		L	ICSA3 [ICSPA3] -BE3HS1L-A- <input type="checkbox"/> - <input type="checkbox"/> - <input type="checkbox"/> - <input type="checkbox"/> -BNM-T1- <input type="checkbox"/> - <input type="checkbox"/>
	4	M	ICSA3 [ICSPA3] -BE4HS1M-A- <input type="checkbox"/> - <input type="checkbox"/> - <input type="checkbox"/> - <input type="checkbox"/> -BNM-T1- <input type="checkbox"/> - <input type="checkbox"/>
		L	ICSA3 [ICSPA3] -BE4HS1L-A- <input type="checkbox"/> - <input type="checkbox"/> - <input type="checkbox"/> - <input type="checkbox"/> -BNM-T1- <input type="checkbox"/> - <input type="checkbox"/>
Incremental	1	M	ICSA3 [ICSPA3] -BE1HS1M-I- <input type="checkbox"/> - <input type="checkbox"/> - <input type="checkbox"/> - <input type="checkbox"/> -BNM-T1- <input type="checkbox"/> - <input type="checkbox"/>
		L	ICSA3 [ICSPA3] -BE1HS1L-I- <input type="checkbox"/> - <input type="checkbox"/> - <input type="checkbox"/> - <input type="checkbox"/> -BNM-T1- <input type="checkbox"/> - <input type="checkbox"/>
	2	M	ICSA3 [ICSPA3] -BE2HS1M-I- <input type="checkbox"/> - <input type="checkbox"/> - <input type="checkbox"/> - <input type="checkbox"/> -BNM-T1- <input type="checkbox"/> - <input type="checkbox"/>
		L	ICSA3 [ICSPA3] -BE2HS1L-I- <input type="checkbox"/> - <input type="checkbox"/> - <input type="checkbox"/> - <input type="checkbox"/> -BNM-T1- <input type="checkbox"/> - <input type="checkbox"/>
	3	M	ICSA3 [ICSPA3] -BE3HS1M-I- <input type="checkbox"/> - <input type="checkbox"/> - <input type="checkbox"/> - <input type="checkbox"/> -BNM-T1- <input type="checkbox"/> - <input type="checkbox"/>
		L	ICSA3 [ICSPA3] -BE3HS1L-I- <input type="checkbox"/> - <input type="checkbox"/> - <input type="checkbox"/> - <input type="checkbox"/> -BNM-T1- <input type="checkbox"/> - <input type="checkbox"/>
	4	M	ICSA3 [ICSPA3] -BE4HS1M-I- <input type="checkbox"/> - <input type="checkbox"/> - <input type="checkbox"/> - <input type="checkbox"/> -BNM-T1- <input type="checkbox"/> - <input type="checkbox"/>
		L	ICSA3 [ICSPA3] -BE4HS1L-I- <input type="checkbox"/> - <input type="checkbox"/> - <input type="checkbox"/> - <input type="checkbox"/> -BNM-T1- <input type="checkbox"/> - <input type="checkbox"/>

\*1: Refer to the figure below for XY-axis configuration direction.  
 \*2: The load capacity and the maximum speed may vary depending on the type of Z-axis.  
 Note: T1 in the above models will be T2 when operated with XSEL-P/Q type.

**Explanation of Model Code**

Number	Contents	Specification
<input type="checkbox"/>	X-axis stroke (Note 1)	30 : 300mm ~ 100 : 1000mm
<input type="checkbox"/>	Y-axis stroke (Note 1)	20 : 200mm ~ 70 : 700mm
<input type="checkbox"/>	Z-axis stroke (Note 1)	10 : 100mm ~ 40 : 400mm
<input type="checkbox"/>	Cable length (Note 2)	3L : 3m 5L : 5m
<input type="checkbox"/>	Y-axis/ Z-axis cable management	SC-SC : Self-standing cable

\* The above explains the Models/Specifications chart to the left.

**Options**

Please add the option codes at the end of each stroke of the axis.  
 When adding multiple options, put together in alphabetic order.

Name	Code	Page
AQ seal	AQ	• P13
Brake	B	• P13
Creep sensor	C	• P13
Home limit switch	L	• P14
Reversed-home specification	NM	• P14
Guide with ball-retaining mechanism	RT	• P14

**Configuration Direction**

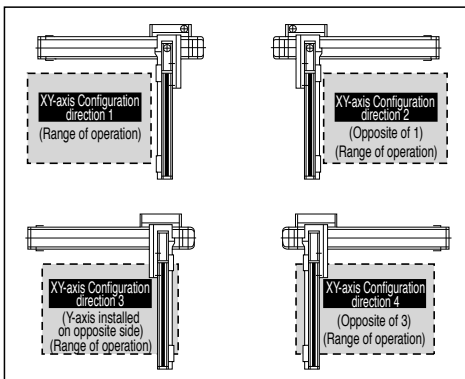

**Common Specifications** \* [ ] is for the high-precision specification.

Drive system	Ball screw, rolled C10 [equivalent to rolled C5]
Positioning repeatability	±0.02mm [±0.01mm]
Backlash	0.05mm or less [0.02mm or less]
Guide	Integrated with base
Base	Material: Aluminum with white alumite treatment
X-axis motor output / lead	400W / 20mm
Y-axis motor output / lead	200W / 20mm
Z-axis motor output / lead	60W / 8mm (M), 4mm (L)

**Applicable Controller Specifications**

Refer to page 65 for System Configuration.

**Axis Configuration** \* [ ] is for the high-precision specification.

Axis Type	Model	Page
X-axis	ISA[ISPA]-LXM- <input type="checkbox"/> -400-20-(Stroke)-T1	• P26
Y-axis	ISA[ISPA]-MYM- <input type="checkbox"/> -200-20-(Stroke)-T1	• P22
Z-axis	ISA[ISPA]-SZM- <input type="checkbox"/> -60-8/4-(Stroke)-T1-B-NM	• P17

\*In the above model name,  indicates encoder type A (absolute) or I (incremental).

**Caution**

(Note 1) The stroke in the model is specified in cm (centimeters).  
 (Note 2) The cable length measures from the X-axis connector box to the controller. The standard lengths are 3m and 5m, but other lengths can also be specified in meters. The maximum length is 20m.  
 (Note 3) The rated acceleration is 0.3G. Increasing the acceleration will result in lower load capacity.  
 (Note 4) Please note that a longer stroke will result in a lower maximum speed.

\* For other points to note, please refer to page 49.



ICSA3 [ICSPA3] - BE□HS1□

Load Capacity (kg) (Note3)

BE□HS1M

		Y-axis stroke					
		200	300	400	500	600	700
Z-axis stroke	100	3.0					
	200	2.3					
	300	1.6					
	400	0.9					

BE□HS1L

		Y-axis stroke					
		200	300	400	500	600	700
Z-axis stroke	100	11.0					
	200	10.3					
	300	9.6					
	400	8.9					

Maximum Speed by Stroke (mm/sec) (Note4)

BE□HS1M

	Stroke										
	100	200	300	400	500	600	700	800	900	1000	
X-axis	-	-	1000						-	830	690
Y-axis	-	1000						-	-	-	-
Z-axis	400			-	-	-	-	-	-	-	

BE□HS1L

	Stroke										
	100	200	300	400	500	600	700	800	900	1000	
X-axis	-	-	1000						-	830	690
Y-axis	-	1000						-	-	-	-
Z-axis	200			-	-	-	-	-	-	-	

Dimensions

\* The dimension below is for XY-axis Configuration direction 1.

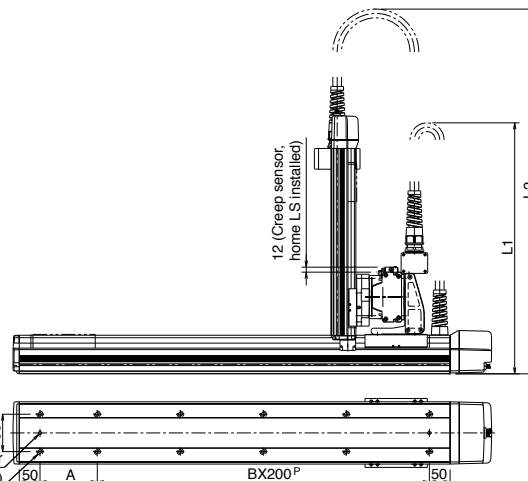
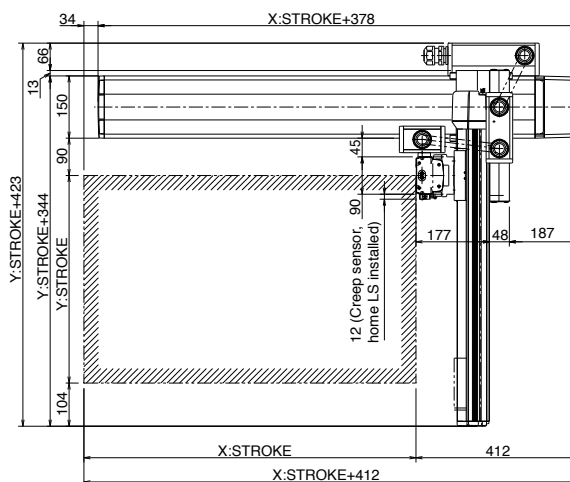
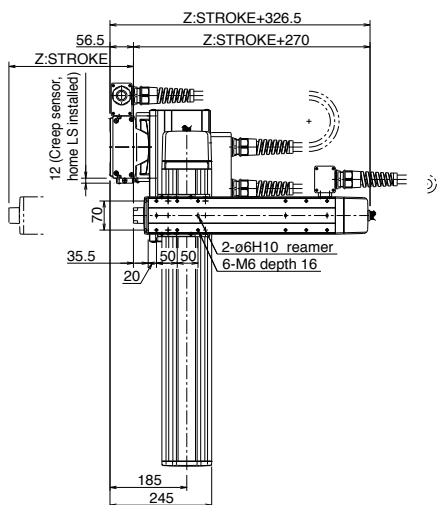

\* The configuration position in the figure is home position. To change the home position, indicate NM in the option. Note that changing the home direction will require the actuator to be returned to IAI for adjustment.

X stroke	300	400	500	600	700	800	900	1000
L1	(600)	(650)	(700)	(750)	(800)	(850)	(900)	(950)
A	238	138	238	138	238	138	238	138
B	1	2	2	3	3	4	4	5
C	6	8	8	10	10	12	12	14

		Y stroke					
		200	300	400	500	600	700
Z stroke	100	(700)	(750)	(800)	(850)	(900)	(950)
	200	(800)	(850)	(900)	(950)	(1000)	(1050)
	300	(900)	(950)	(1000)	(1050)	(1100)	(1150)
	400	(1000)	(1050)	(1100)	(1150)	(1200)	(1250)

<b>ICSA3-BE</b> <input type="checkbox"/> <b>HS1</b> <input type="checkbox"/>		Cartesian Robot: X-Y-Z 3-Axes Configuration Z-Axis Slider Mount Type
<b>ICSPA3-BE</b> <input type="checkbox"/> <b>HS1</b> <input type="checkbox"/>		Cartesian Robot: X-Y-Z 3-Axes Configuration Z-Axis Slider Mount Type <b>High-Precision Specification</b>
Type	XYB + Z-Axis Slider Mount Type	Stroke X-axis: 300~1000mm Y-axis: 200~700mm Z-axis: 100~400mm
Load capacity	11kg ~ 0.9kg	
Model specification items	Series	Type Encoder type X-axis stroke + options Y-axis stroke + options Z-axis stroke + options Applicable controller Cable length Cable management
(Example)	ICSA3 (ICSPA3)	-BE1HS1M-A - A - 50AQL - 40AQL - 30BLNM - T1 - 5L - SC - SC



\* Refer to page 51 for the details of model specification items.

**Models/Specifications** \* [ ] is for the high-precision specification.

Encoder Type	XY-axis configuration direction (*1)	Z-axis type (*2)	Model
Absolute	1	M	ICSA3 [ICSPA3] -BE1HS1M-A- <input type="checkbox"/> <input type="checkbox"/> <input type="checkbox"/> <input type="checkbox"/> <input type="checkbox"/> <input type="checkbox"/> -BNM-T1- <input type="checkbox"/> <input type="checkbox"/>
		L	ICSA3 [ICSPA3] -BE1HS1L-A- <input type="checkbox"/> <input type="checkbox"/> <input type="checkbox"/> <input type="checkbox"/> <input type="checkbox"/> <input type="checkbox"/> -BNM-T1- <input type="checkbox"/> <input type="checkbox"/>
	2	M	ICSA3 [ICSPA3] -BE2HS1M-A- <input type="checkbox"/> <input type="checkbox"/> <input type="checkbox"/> <input type="checkbox"/> <input type="checkbox"/> <input type="checkbox"/> -BNM-T1- <input type="checkbox"/> <input type="checkbox"/>
		L	ICSA3 [ICSPA3] -BE2HS1L-A- <input type="checkbox"/> <input type="checkbox"/> <input type="checkbox"/> <input type="checkbox"/> <input type="checkbox"/> <input type="checkbox"/> -BNM-T1- <input type="checkbox"/> <input type="checkbox"/>
	3	M	ICSA3 [ICSPA3] -BE3HS1M-A- <input type="checkbox"/> <input type="checkbox"/> <input type="checkbox"/> <input type="checkbox"/> <input type="checkbox"/> <input type="checkbox"/> -BNM-T1- <input type="checkbox"/> <input type="checkbox"/>
		L	ICSA3 [ICSPA3] -BE3HS1L-A- <input type="checkbox"/> <input type="checkbox"/> <input type="checkbox"/> <input type="checkbox"/> <input type="checkbox"/> <input type="checkbox"/> -BNM-T1- <input type="checkbox"/> <input type="checkbox"/>
	4	M	ICSA3 [ICSPA3] -BE4HS1M-A- <input type="checkbox"/> <input type="checkbox"/> <input type="checkbox"/> <input type="checkbox"/> <input type="checkbox"/> <input type="checkbox"/> -BNM-T1- <input type="checkbox"/> <input type="checkbox"/>
		L	ICSA3 [ICSPA3] -BE4HS1L-A- <input type="checkbox"/> <input type="checkbox"/> <input type="checkbox"/> <input type="checkbox"/> <input type="checkbox"/> <input type="checkbox"/> -BNM-T1- <input type="checkbox"/> <input type="checkbox"/>
Incremental	1	M	ICSA3 [ICSPA3] -BE1HS1M-I- <input type="checkbox"/> <input type="checkbox"/> <input type="checkbox"/> <input type="checkbox"/> <input type="checkbox"/> <input type="checkbox"/> -BNM-T1- <input type="checkbox"/> <input type="checkbox"/>
		L	ICSA3 [ICSPA3] -BE1HS1L-I- <input type="checkbox"/> <input type="checkbox"/> <input type="checkbox"/> <input type="checkbox"/> <input type="checkbox"/> <input type="checkbox"/> -BNM-T1- <input type="checkbox"/> <input type="checkbox"/>
	2	M	ICSA3 [ICSPA3] -BE2HS1M-I- <input type="checkbox"/> <input type="checkbox"/> <input type="checkbox"/> <input type="checkbox"/> <input type="checkbox"/> <input type="checkbox"/> -BNM-T1- <input type="checkbox"/> <input type="checkbox"/>
		L	ICSA3 [ICSPA3] -BE2HS1L-I- <input type="checkbox"/> <input type="checkbox"/> <input type="checkbox"/> <input type="checkbox"/> <input type="checkbox"/> <input type="checkbox"/> -BNM-T1- <input type="checkbox"/> <input type="checkbox"/>
	3	M	ICSA3 [ICSPA3] -BE3HS1M-I- <input type="checkbox"/> <input type="checkbox"/> <input type="checkbox"/> <input type="checkbox"/> <input type="checkbox"/> <input type="checkbox"/> -BNM-T1- <input type="checkbox"/> <input type="checkbox"/>
		L	ICSA3 [ICSPA3] -BE3HS1L-I- <input type="checkbox"/> <input type="checkbox"/> <input type="checkbox"/> <input type="checkbox"/> <input type="checkbox"/> <input type="checkbox"/> -BNM-T1- <input type="checkbox"/> <input type="checkbox"/>
	4	M	ICSA3 [ICSPA3] -BE4HS1M-I- <input type="checkbox"/> <input type="checkbox"/> <input type="checkbox"/> <input type="checkbox"/> <input type="checkbox"/> <input type="checkbox"/> -BNM-T1- <input type="checkbox"/> <input type="checkbox"/>
		L	ICSA3 [ICSPA3] -BE4HS1L-I- <input type="checkbox"/> <input type="checkbox"/> <input type="checkbox"/> <input type="checkbox"/> <input type="checkbox"/> <input type="checkbox"/> -BNM-T1- <input type="checkbox"/> <input type="checkbox"/>

\*1: Refer to the figure below for XY-axis configuration direction.  
\*2: The load capacity and the maximum speed may vary depending on the type of Z-axis.  
Note: T1 in the above models will be T2 when operated with XSEL-P/Q type.

**Explanation of Model Code**

Number	Contents	Specification
<input type="checkbox"/>	X-axis stroke (Note 1)	30 : 300mm ~ 100 : 1000mm
<input type="checkbox"/>	Y-axis stroke (Note 1)	20 : 200mm ~ 70 : 700mm
<input type="checkbox"/>	Z-axis stroke (Note 1)	10 : 100mm ~ 40 : 400mm
<input type="checkbox"/>	Cable length (Note 2)	3L : 3m 5L : 5m
<input type="checkbox"/>	Y-axis/ Z-axis cable management	SC-SC : Self-standing cable

\* The above explains the Models/Specifications chart to the left.

**Options**

Please add the option codes at the end of each stroke of the axis.  
When adding multiple options, put together in alphabetic order.

Name	Code	Page
AQ seal	AQ	• P13
Brake	B	• P13
Creep sensor	C	• P13
Home limit switch	L	• P14
Reversed-home specification	NM	• P14
Guide with ball-retaining mechanism	RT	• P14

**Configuration Direction**

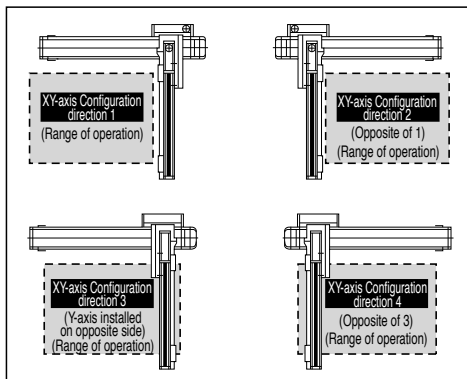

**Common Specifications** \* [ ] is for the high-precision specification.

Drive system	Ball screw, rolled C10 [equivalent to rolled C5]
Positioning repeatability	±0.02mm [±0.01mm]
Backlash	0.05mm or less [0.02mm or less]
Guide	Integrated with base
Base	Material: Aluminum with white alumite treatment
X-axis motor output / lead	400W / 20mm
Y-axis motor output / lead	200W / 20mm
Z-axis motor output / lead	60W / 8mm (M), 4mm (L)

**Applicable Controller Specifications**

Refer to page 65 for System Configuration.

**Axis Configuration** \* [ ] is for the high-precision specification.

Axis Type	Model	Page
X-axis	ISA[ISPA]-LXM- <input type="checkbox"/> -400-20-(Stroke)-T1	• P26
Y-axis	ISA[ISPA]-MYM- <input type="checkbox"/> -200-20-(Stroke)-T1	• P22
Z-axis	ISA[ISPA]-SZM- <input type="checkbox"/> -60-8/4-(Stroke)-T1-B-NM	• P17

\*In the above model name,  indicates encoder type A (absolute) or I (incremental).

**Caution**

(Note 1) The stroke in the model is specified in cm (centimeters).  
 (Note 2) The cable length measures from the X-axis connector box to the controller. The standard lengths are 3m and 5m, but other lengths can also be specified in meters. The maximum length is 20m.  
 (Note 3) The rated acceleration is 0.3G. Increasing the acceleration will result in lower load capacity.  
 (Note 4) Please note that a longer stroke will result in a lower maximum speed.

\* For other points to note, please refer to page 49.

**ICSA3 [ICSPA3] - BE□HS3M**

**Load Capacity (kg) (Note3)**

**BE□HS3M**

		Y-axis stroke					
		200	300	400	500	600	700
Z-axis stroke	100	11.9					10.5
	200	10.9					9.5
	300	9.9					8.5
	400	8.9					7.5

**Maximum Speed by Stroke (mm/sec) (Note4)**

**BE□HS3M**

	Stroke										
	100	200	300	400	500	600	700	800	900	1000	
X-axis	-	-	1000						830	690	
Y-axis	-	1000						-	-	-	
Z-axis	500			-	-	-	-	-	-	-	

**Dimensions** \* The dimension below is for XY-axis Configuration direction 1.

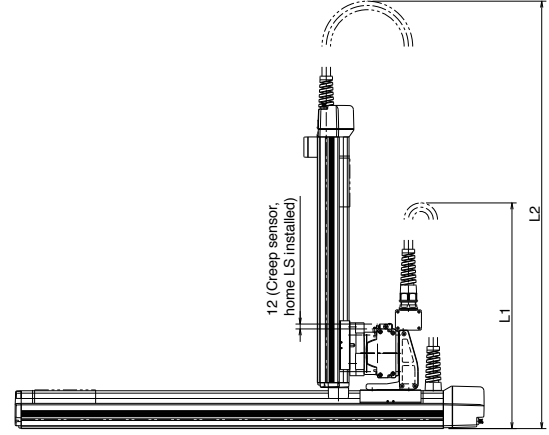
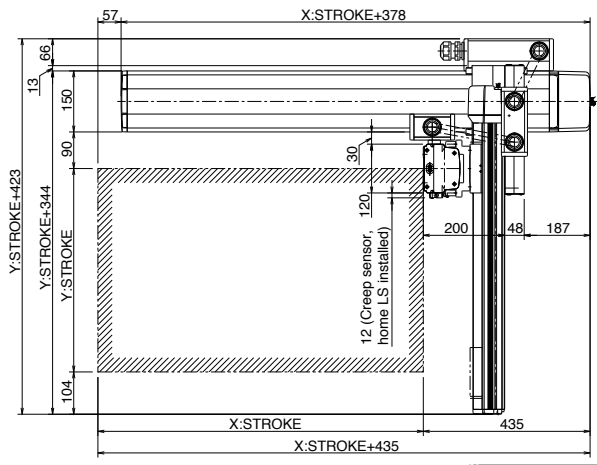
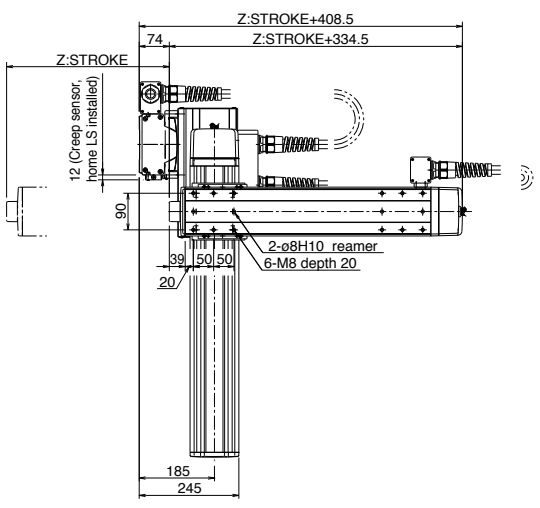

\* The configuration position in the figure is home position. To change the home position, indicate NM in the option. Note that changing the home direction will require the actuator to be returned to IAI for adjustment.

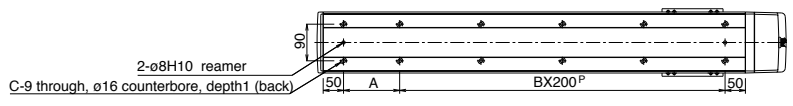

X stroke	300	400	500	600	700	800	900	1000
L1	(600)	(650)	(700)	(750)	(800)	(850)	(900)	(950)
A	238	138	238	138	238	138	238	138
B	1	2	2	3	3	4	4	5
C	6	8	8	10	10	12	12	14

		Y stroke					
		200	300	400	500	600	700
Z stroke	100	(720)	(770)	(820)	(870)	(920)	(970)
	200	(820)	(870)	(920)	(970)	(1020)	(1070)
	300	(920)	(970)	(1020)	(1070)	(1120)	(1170)
	400	(1020)	(1070)	(1120)	(1170)	(1220)	(1270)

**ICSA3-BE MS1** Cartesian Robot: X-Y-Z 3-Axes Configuration  
Z-Axis Slider Mount Type

**ICSPA3-BE MS1** Cartesian Robot: X-Y-Z 3-Axes Configuration  
Z-Axis Slider Mount Type High-Precision Specification

Type XYB + Z-Axis Slider Mount Type Stroke X-axis: 300-1000mm Y-axis: 200-700mm Z-axis: 100-400mm Load capacity 11kg - 0.9kg

Model specification items	Series	Type	Encoder type	X-axis stroke + options	Y-axis stroke + options	Z-axis stroke + options	Applicable controller	Cable length	Cable management
(Example)	ICSA3 (ICSPA3)	-BE1MS1M-	A	- 50AQL	- 40AQL	- 30BLNM	- T1	- 5L	- SC - SC



\* Refer to page 51 for the details of model specification items.

**Models/Specifications** \* [ ] is for the high-precision specification.

Encoder Type	XY-axis configuration direction (*1)	Z-axis type (*2)	Model
Absolute	1	M	ICSA3 [ICSPA3] -BE1MS1M-A-[1]-[2]-[3]-BNM-T1-[4]-[5]
		L	ICSA3 [ICSPA3] -BE1MS1L-A-[1]-[2]-[3]-BNM-T1-[4]-[5]
	2	M	ICSA3 [ICSPA3] -BE2MS1M-A-[1]-[2]-[3]-BNM-T1-[4]-[5]
		L	ICSA3 [ICSPA3] -BE2MS1L-A-[1]-[2]-[3]-BNM-T1-[4]-[5]
	3	M	ICSA3 [ICSPA3] -BE3MS1M-A-[1]-[2]-[3]-BNM-T1-[4]-[5]
		L	ICSA3 [ICSPA3] -BE3MS1L-A-[1]-[2]-[3]-BNM-T1-[4]-[5]
4	M	ICSA3 [ICSPA3] -BE4MS1M-A-[1]-[2]-[3]-BNM-T1-[4]-[5]	
	L	ICSA3 [ICSPA3] -BE4MS1L-A-[1]-[2]-[3]-BNM-T1-[4]-[5]	
Incremental	1	M	ICSA3 [ICSPA3] -BE1MS1M-I-[1]-[2]-[3]-BNM-T1-[4]-[5]
		L	ICSA3 [ICSPA3] -BE1MS1L-I-[1]-[2]-[3]-BNM-T1-[4]-[5]
	2	M	ICSA3 [ICSPA3] -BE2MS1M-I-[1]-[2]-[3]-BNM-T1-[4]-[5]
		L	ICSA3 [ICSPA3] -BE2MS1L-I-[1]-[2]-[3]-BNM-T1-[4]-[5]
	3	M	ICSA3 [ICSPA3] -BE3MS1M-I-[1]-[2]-[3]-BNM-T1-[4]-[5]
		L	ICSA3 [ICSPA3] -BE3MS1L-I-[1]-[2]-[3]-BNM-T1-[4]-[5]
	4	M	ICSA3 [ICSPA3] -BE4MS1M-I-[1]-[2]-[3]-BNM-T1-[4]-[5]
		L	ICSA3 [ICSPA3] -BE4MS1L-I-[1]-[2]-[3]-BNM-T1-[4]-[5]

\*1: Refer to the figure below for XY-axis configuration direction.  
\*2: The load capacity and the maximum speed may vary depending on the type of Z-axis.  
Note: T1 in the above models will be T2 when operated with XSEL-P/Q type.

**Explanation of Model Code**

Number	Contents	Specification
①	X-axis stroke (Note 1)	30 : 300mm ~ 100 : 1000mm
②	Y-axis stroke (Note 1)	20 : 200mm ~ 70 : 700mm
③	Z-axis stroke (Note 1)	10 : 100mm ~ 40 : 400mm
④	Cable length (Note 2)	3L : 3m 5L : 5m
⑤	Y-axis/ Z-axis cable management	SC-SC : Self-standing cable

\* The above explains the Models/Specifications chart to the left.

**Options**

Please add the option codes at the end of each stroke of the axis.  
When adding multiple options, put together in alphabetic order.

Name	Code	Page
AQ seal	AQ	→P13
Brake	B	→P13
Creep sensor	C	→P13
Home limit switch	L	→P14
Reversed-home specification	NM	→P14
Guide with ball-retaining mechanism	RT	→P14

**Configuration Direction**

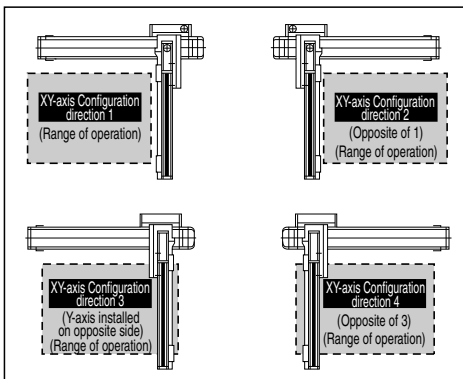

**Common Specifications** \* [ ] is for the high-precision specification.

Drive system	Ball screw, rolled C10 [equivalent to rolled C5]
Positioning repeatability	±0.02mm [±0.01mm]
Backlash	0.05mm or less [0.02mm or less]
Guide	Integrated with base
Base	Material: Aluminum with white alumite treatment
X-axis motor output / lead	200W / 10mm
Y-axis motor output / lead	200W / 10mm
Z-axis motor output / lead	60W / 8mm (M), 4mm (L)

**Applicable Controller Specifications**

Refer to page 65 for System Configuration.

**Axis Configuration** \* [ ] is for the high-precision specification.

Axis Type	Model	Page
X-axis	ISA[ISPA]-LXM-[ ]-200-10-(Stroke)-T1	→P25
Y-axis	ISA[ISPA]-MYM-[ ]-200-10-(Stroke)-T1	→P22
Z-axis	ISA[ISPA]-SZM-[ ]-60-8/4-(Stroke)-T1-B-NM	→P17

\*In the above model name, [ ] indicates encoder type A (absolute) or I (incremental).

**Caution**

(Note 1) The stroke in the model is specified in cm (centimeters).  
 (Note 2) The cable length measures from the X-axis connector box to the controller. The standard lengths are 3m and 5m, but other lengths can also be specified in meters. The maximum length is 20m.  
 (Note 3) The rated acceleration is 0.3G. Increasing the acceleration will result in lower load capacity.  
 (Note 4) Please note that a longer stroke will result in a lower maximum speed.

\* For other points to note, please refer to page 49.

ICSA3 [ICSPA3] - BE□MS1□

Load Capacity (kg) (Note3)

BE□MS1M

		Y-axis stroke					
		200	300	400	500	600	700
Z-axis stroke	100	3.0					
	200	2.3					
	300	1.6					
	400	0.9					

BE□MS1L

		Y-axis stroke					
		200	300	400	500	600	700
Z-axis stroke	100	11.0					
	200	10.3					
	300	9.6					
	400	8.9					

Maximum Speed by Stroke (mm/sec) (Note4)

BE□MS1M

	Stroke										
	100	200	300	400	500	600	700	800	900	1000	
X-axis	-	-	500					470	385	320	
Y-axis	-	500					480	-	-	-	
Z-axis	400		-	-	-	-	-	-	-	-	

BE□MS1L

	Stroke										
	100	200	300	400	500	600	700	800	900	1000	
X-axis	-	-	500					470	385	320	
Y-axis	-	500					480	-	-	-	
Z-axis	200		-	-	-	-	-	-	-	-	

Dimensions

\* The dimension below is for XY-axis Configuration direction 1.

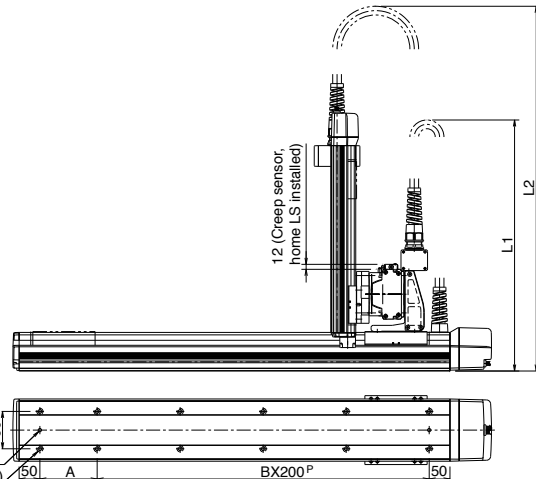
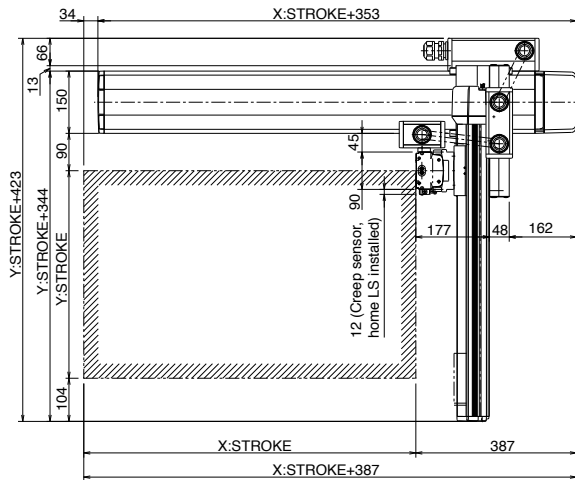
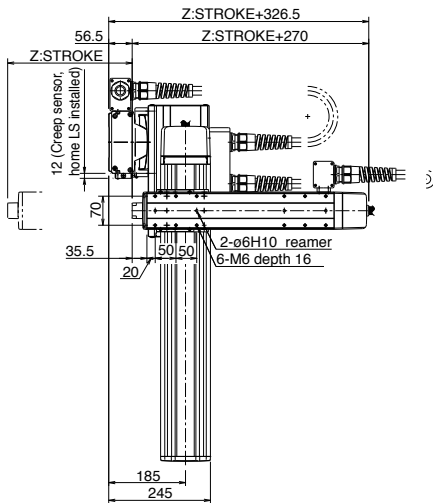

\* The configuration position in the figure is home position. To change the home position, indicate NM in the option. Note that changing the home direction will require the actuator to be returned to IAI for adjustment.

X stroke	300	400	500	600	700	800	900	1000
L1	(600)	(650)	(700)	(750)	(800)	(850)	(900)	(950)
A	238	138	238	138	238	138	238	138
B	1	2	2	3	3	4	4	5
C	6	8	8	10	10	12	12	14

		Y stroke					
		200	300	400	500	600	700
Z stroke	100	(700)	(750)	(800)	(850)	(900)	(950)
	200	(800)	(850)	(900)	(950)	(1000)	(1050)
	300	(900)	(950)	(1000)	(1050)	(1100)	(1150)
	400	(1000)	(1050)	(1100)	(1150)	(1200)	(1250)

**ICSA3-BE MS3M** Cartesian Robot: X-Y-Z 3-Axes Configuration  
Z-Axis Slider Mount Type

**ICSPA3-BE MS3M** Cartesian Robot: X-Y-Z 3-Axes Configuration  
Z-Axis Slider Mount Type **High-Precision Specification**

Type XYB + Z-Axis Slider Mount Type Stroke X-axis: 300-1000mm Y-axis: 200-700mm Z-axis: 100-400mm Load capacity 11.9kg - 7.5kg

Model specification items	Series	Type	Encoder type	X-axis stroke + options	Y-axis stroke + options	Z-axis stroke + options	Applicable controller	Cable length	Cable management
(Example)	ICSA3 (ICSPA3)	-BE1MS3M-	A	- 50AQL	- 40AQL	- 30BLNM	- T1	- 5L	- SC - SC



\* Refer to page 51 for the details of model specification items.

**Models/Specifications**

\* [ ] is for the high-precision specification.

Encoder Type	XY-axis configuration direction (*1)	Z-axis type (*2)	Model
Absolute	1	M	ICSA3 [ICSPA3] -BE1MS3M-A-①-②-③-BNM-T1-④-⑤
	2	M	ICSA3 [ICSPA3] -BE2MS3M-A-①-②-③-BNM-T1-④-⑤
	3	M	ICSA3 [ICSPA3] -BE3MS3M-A-①-②-③-BNM-T1-④-⑤
	4	M	ICSA3 [ICSPA3] -BE4MS3M-A-①-②-③-BNM-T1-④-⑤
Incremental	1	M	ICSA3 [ICSPA3] -BE1MS3M-I-①-②-③-BNM-T1-④-⑤
	2	M	ICSA3 [ICSPA3] -BE2MS3M-I-①-②-③-BNM-T1-④-⑤
	3	M	ICSA3 [ICSPA3] -BE3MS3M-I-①-②-③-BNM-T1-④-⑤
	4	M	ICSA3 [ICSPA3] -BE4MS3M-I-①-②-③-BNM-T1-④-⑤

\*1: Refer to the figure below for XY-axis configuration direction.

\*2: The load capacity and the maximum speed may vary depending on the type of Z-axis.

Note: T1 in the above models will be T2 when operated with XSEL-P/Q type.

**Explanation of Model Code**

Number	Contents	Specification
①	X-axis stroke (Note 1)	30 : 300mm ~ 100 : 1000mm
②	Y-axis stroke (Note 1)	20 : 200mm ~ 70 : 700mm
③	Z-axis stroke (Note 1)	10 : 100mm ~ 40 : 400mm
④	Cable length (Note 2)	3L : 3m 5L : 5m
⑤	Y-axis/ Z-axis cable management	SC-SC : Self-standing cable

\* The above explains the Models/Specifications chart to the left.

**Options**

Please add the option codes at the end of each stroke of the axis. When adding multiple options, put together in alphabetic order.

Name	Code	Page
AQ seal	AQ	→P13
Brake	B	→P13
Creep sensor	C	→P13
Home limit switch	L	→P14
Reversed-home specification	NM	→P14
Guide with ball-retaining mechanism	RT	→P14

**Configuration Direction**

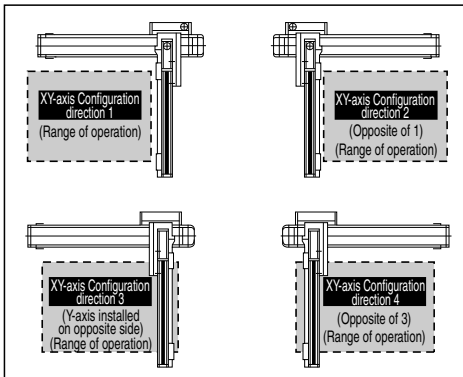

**Common Specifications**

\* [ ] is for the high-precision specification.

Drive system	Ball screw, rolled C10 [equivalent to rolled C5]
Positioning repeatability	±0.02mm [±0.01mm]
Backlash	0.05mm or less [0.02mm or less]
Guide	Integrated with base
Base	Material: Aluminum with white alumite treatment
X-axis motor output / lead	200W / 10mm
Y-axis motor output / lead	200W / 10mm
Z-axis motor output / lead	200W / 10mm (M)

**Applicable Controller Specifications**

Refer to page 65 for System Configuration.

**Axis Configuration**

\* [ ] is for the high-precision specification.

Axis Type	Model	Page
X-axis	ISA[ISPA]-LXM-□-200-10-(Stroke)-T1	→P25
Y-axis	ISA[ISPA]-MYM-□-200-10-(Stroke)-T1	→P22
Z-axis	ISA[ISPA]-MZM-□-200-10-(Stroke)-T1-B-NM	→P24

\*In the above model name, □ indicates encoder type A (absolute) or I (incremental).

**Caution**

(Note 1) The stroke in the model is specified in cm (centimeters).  
 (Note 2) The cable length measures from the X-axis connector box to the controller. The standard lengths are 3m and 5m, but other lengths can also be specified in meters. The maximum length is 20m.  
 (Note 3) The rated acceleration is 0.3G. Increasing the acceleration will result in lower load capacity.  
 (Note 4) Please note that a longer stroke will result in a lower maximum speed.

\* For other points to note, please refer to page 49.

**ICSA3 [ICSPA3] - BE□MS3M**

**Load Capacity (kg) (Note3)**

**BE□MS3M**

		Y-axis stroke					
		200	300	400	500	600	700
Z-axis stroke	100	11.9					10.5
	200	10.9					9.5
	300	9.9					8.5
	400	8.9					7.5

**Maximum Speed by Stroke (mm/sec) (Note4)**

**BE□MS3M**

	Stroke										
	100	200	300	400	500	600	700	800	900	1000	
X-axis	-	-	500					470	385	320	
Y-axis	-	500					480	-	-	-	
Z-axis	500			-	-	-	-	-	-	-	

**Dimensions**

\* The dimension below is for XY-axis Configuration direction 1.

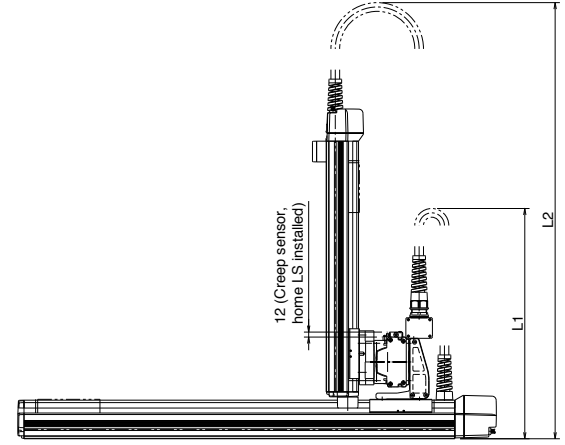
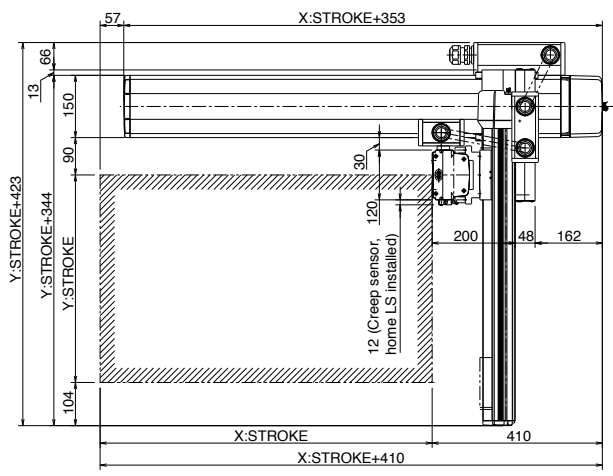
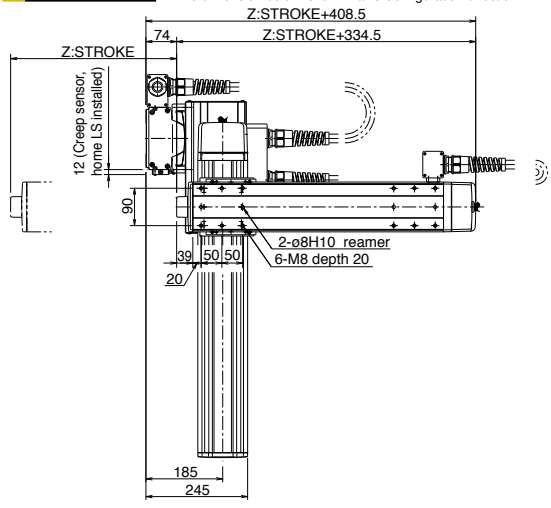

\* The configuration position in the figure is home position. To change the home position, indicate NM in the option. Note that changing the home direction will require the actuator to be returned to IAI for adjustment.

2-ø8H10 reamer  
C-9 through, ø16 counterbore, depth1 (back)

X stroke	300	400	500	600	700	800	900	1000
L1	(600)	(650)	(700)	(750)	(800)	(850)	(900)	(950)
A	238	138	238	138	238	138	238	138
B	1	2	2	3	3	4	4	5
C	6	8	8	10	10	12	12	14

		Y stroke						
		200	300	400	500	600	700	
Z stroke	100	(720)	(770)	(820)	(870)	(920)	(970)	
	200	(820)	(870)	(920)	(970)	(1020)	(1070)	
	300	(920)	(970)	(1020)	(1070)	(1120)	(1170)	
	400	(1020)	(1070)	(1120)	(1170)	(1220)	(1270)	

**ICSA3-BF**  **HS1**  Cartesian Robot: X-Y-Z 3-Axes Configuration  
Z-Axis Slider Mount Type

**ICSPA3-BF**  **HS1**  Cartesian Robot: X-Y-Z 3-Axes Configuration  
Z-Axis Slider Mount Type **High-Precision Specification**

Type XYB + Z-Axis Slider Mount Type Stroke X-axis: 1000-2500mm Y-axis: 200-700mm Z-axis: 100-400mm Load capacity 11kg - 0.9kg

Model specification items Series Type Encoder type X-axis stroke + options Y-axis stroke + options Z-axis stroke + options Applicable controller Cable length Cable management  
(Example) ICSA3 (ICSPA3) - BF1HS1M - A - 100AQL - 40AQL - 30BLNM - T1 - 5L - CT - SC

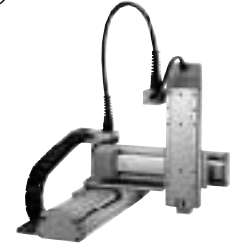

\* Refer to page 51 for the details of model specification items.

**Models/Specifications**

\* [ ] is for the high-precision specification.

Encoder Type	XY-axis configuration direction (*1)	Z-axis type (*2)	Model
Absolute	1	M	ICSA3 [ICSPA3] -BF1HS1M-A- <input type="checkbox"/> - <input type="checkbox"/> - <input type="checkbox"/> -BNM-T1- <input type="checkbox"/> - <input type="checkbox"/>
		L	ICSA3 [ICSPA3] -BF1HS1L-A- <input type="checkbox"/> - <input type="checkbox"/> - <input type="checkbox"/> -BNM-T1- <input type="checkbox"/> - <input type="checkbox"/>
	2	M	ICSA3 [ICSPA3] -BF2HS1M-A- <input type="checkbox"/> - <input type="checkbox"/> - <input type="checkbox"/> -BNM-T1- <input type="checkbox"/> - <input type="checkbox"/>
		L	ICSA3 [ICSPA3] -BF2HS1L-A- <input type="checkbox"/> - <input type="checkbox"/> - <input type="checkbox"/> -BNM-T1- <input type="checkbox"/> - <input type="checkbox"/>
	3	M	ICSA3 [ICSPA3] -BF3HS1M-A- <input type="checkbox"/> - <input type="checkbox"/> - <input type="checkbox"/> -BNM-T1- <input type="checkbox"/> - <input type="checkbox"/>
		L	ICSA3 [ICSPA3] -BF3HS1L-A- <input type="checkbox"/> - <input type="checkbox"/> - <input type="checkbox"/> -BNM-T1- <input type="checkbox"/> - <input type="checkbox"/>
	4	M	ICSA3 [ICSPA3] -BF4HS1M-A- <input type="checkbox"/> - <input type="checkbox"/> - <input type="checkbox"/> -BNM-T1- <input type="checkbox"/> - <input type="checkbox"/>
		L	ICSA3 [ICSPA3] -BF4HS1L-A- <input type="checkbox"/> - <input type="checkbox"/> - <input type="checkbox"/> -BNM-T1- <input type="checkbox"/> - <input type="checkbox"/>
Incremental	1	M	ICSA3 [ICSPA3] -BF1HS1M-I- <input type="checkbox"/> - <input type="checkbox"/> - <input type="checkbox"/> -BNM-T1- <input type="checkbox"/> - <input type="checkbox"/>
		L	ICSA3 [ICSPA3] -BF1HS1L-I- <input type="checkbox"/> - <input type="checkbox"/> - <input type="checkbox"/> -BNM-T1- <input type="checkbox"/> - <input type="checkbox"/>
	2	M	ICSA3 [ICSPA3] -BF2HS1M-I- <input type="checkbox"/> - <input type="checkbox"/> - <input type="checkbox"/> -BNM-T1- <input type="checkbox"/> - <input type="checkbox"/>
		L	ICSA3 [ICSPA3] -BF2HS1L-I- <input type="checkbox"/> - <input type="checkbox"/> - <input type="checkbox"/> -BNM-T1- <input type="checkbox"/> - <input type="checkbox"/>
	3	M	ICSA3 [ICSPA3] -BF3HS1M-I- <input type="checkbox"/> - <input type="checkbox"/> - <input type="checkbox"/> -BNM-T1- <input type="checkbox"/> - <input type="checkbox"/>
		L	ICSA3 [ICSPA3] -BF3HS1L-I- <input type="checkbox"/> - <input type="checkbox"/> - <input type="checkbox"/> -BNM-T1- <input type="checkbox"/> - <input type="checkbox"/>
	4	M	ICSA3 [ICSPA3] -BF4HS1M-I- <input type="checkbox"/> - <input type="checkbox"/> - <input type="checkbox"/> -BNM-T1- <input type="checkbox"/> - <input type="checkbox"/>
		L	ICSA3 [ICSPA3] -BF4HS1L-I- <input type="checkbox"/> - <input type="checkbox"/> - <input type="checkbox"/> -BNM-T1- <input type="checkbox"/> - <input type="checkbox"/>

\*1: Refer to the figure below for XY-axis configuration direction.  
\*2: The load capacity and the maximum speed may vary depending on the type of Z-axis.  
Note: T1 in the above models will be T2 when operated with XSEL-P/Q type.

**Explanation of Model Code**

Number	Contents	Specification
①	X-axis stroke (Note 1)	100 : 1000mm ~ 250 : 2500mm
②	Y-axis stroke (Note 1)	20 : 200mm ~ 70 : 700mm
③	Z-axis stroke (Note 1)	10 : 100mm ~ 40 : 400mm
④	Cable length (Note 2)	3L : 3m 5L : 5m
⑤	Y-axis/ Z-axis cable management	CT-SC : Self-standing cable (*3)

\* The above explains the Models/Specifications chart to the left.  
\*3 Only cable track can be specified for the Y-axis cable management with model # BF□HS1□.

**Options**

Please add the option codes at the end of each stroke of the axis.  
When adding multiple options, put together in alphabetic order.

Name	Code	Page
AQ seal	AQ	→P13
Brake	B	→P13
Creep sensor	C	→P13
Home limit switch	L	→P14
Reversed-home specification	NM	→P14
Guide with ball-retaining mechanism	RT	→P14

**Configuration Direction**

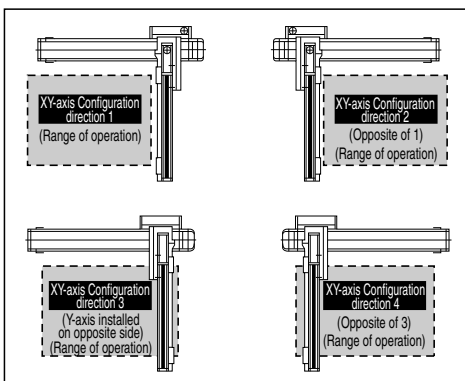

**Common Specifications**

\* [ ] is for the high-precision specification.

Drive system	Ball screw, rolled C10 [equivalent to rolled C5]
Positioning repeatability	±0.02mm [±0.01mm]
Backlash	0.05mm or less [0.02mm or less]
Guide	Integrated with base
Base	Material: Aluminum with white alumite treatment
X-axis motor output / lead	400W / 20mm
Y-axis motor output / lead	200W / 20mm
Z-axis motor output / lead	60W / 8mm (M), 4mm (L)

**Applicable Controller Specifications**

Refer to page 65 for System Configuration.

**Axis Configuration**

\* [ ] is for the high-precision specification.

Axis Type	Model	Page
X-axis	ISA[ISPA]-LXMX-□-400-20-(Stroke)-T1	→P28
Y-axis	ISA[ISPA]-MYM-□-200-20-(Stroke)-T1	→P22
Z-axis	ISA[ISPA]-SZM-□-60-8/4-(Stroke)-T1-B-NM	→P17

\*In the above model name, □ indicates encoder type A (absolute) or I (incremental).

**Caution**

(Note 1) The stroke in the model is specified in cm (centimeters).  
(Note 2) The cable length measures from the X-axis connector box to the controller. The standard lengths are 3m and 5m, but other lengths can also be specified in meters. The maximum length is 20m.  
(Note 3) The rated acceleration is 0.3G. Increasing the acceleration will result in lower load capacity.  
(Note 4) Please note that a longer stroke will result in a lower maximum speed.

\* For other points to note, please refer to page 49.



**ICSA3 [ICSPA3] -BF□HS1□**

**Load Capacity (kg) (Note3)**

**BF□HS1M**

		Y-axis stroke					
		200	300	400	500	600	700
Z-axis stroke	100	3.0					
	200	2.3					
	300	1.6					
	400	0.9					

**BF□HS1L**

		Y-axis stroke					
		200	300	400	500	600	700
Z-axis stroke	100	11.0					
	200	10.3					
	300	9.6					
	400	8.9					

**Maximum Speed by Stroke (mm/sec) (Note4)**

**BF□HS1M**

	Stroke																
	100	200~400	500	600	700	1000~1400	1500	1600	1700	1800	1900	2000	2100	2200	2300	2400	2500
X-axis	-	-	-	-	-	1000	950	830	740	650	590	540	490	440	410	370	300
Y-axis	1000					-	-	-	-	-	-	-	-	-	-	-	-
Z-axis	400	-	-	-	-	-	-	-	-	-	-	-	-	-	-	-	-

**BF□HS1L**

	Stroke																
	100	200~400	500	600	700	1000~1400	1500	1600	1700	1800	1900	2000	2100	2200	2300	2400	2500
X-axis	-	-	-	-	-	1000	950	830	740	650	590	540	490	440	410	370	300
Y-axis	1000					-	-	-	-	-	-	-	-	-	-	-	-
Z-axis	200	-	-	-	-	-	-	-	-	-	-	-	-	-	-	-	-

**Dimensions**

\* The dimension below is for XY-axis Configuration direction 1.

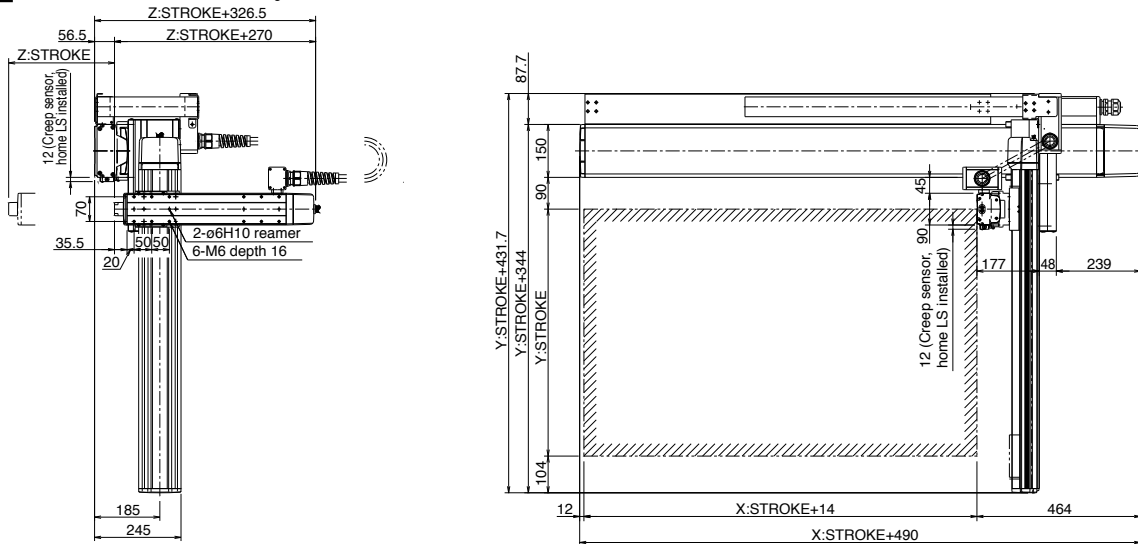

\* The configuration position in the figure is home position. To change the home position, indicate NM in the option. Note that changing the home direction will require the actuator to be returned to IAI for adjustment.

X st	A	B	C	D
1000	225	0	0	12
1100	275	0	0	12
1200	325	0	0	12
1300	375	0	0	12
1400	425	0	0	12
1500	475	0	0	12
1600	525	0	0	12
1700	575	0	0	12
1800	200	425	0	16
1900	200	475	0	16
2000	200	525	0	16
2100	200	575	0	16
2200	200	200	425	20
2300	200	200	475	20
2400	200	200	525	20
2500	200	200	575	20

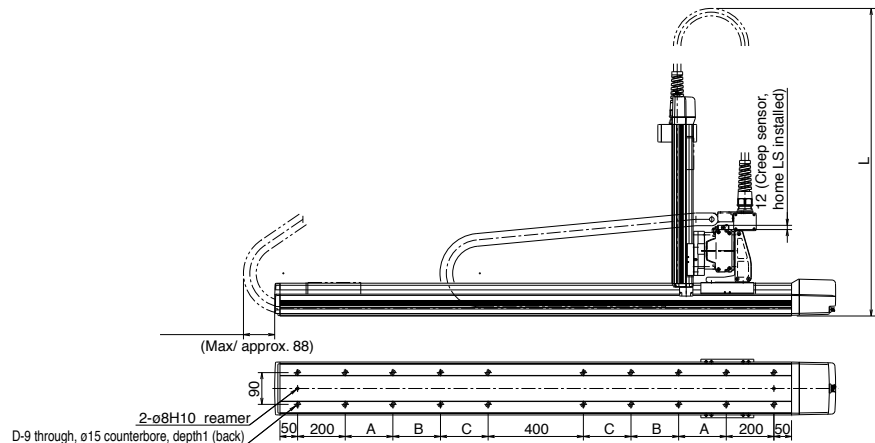

		Y stroke						
		200	300	400	500	600	700	
Z stroke	100	(700)	(750)	(800)	(850)	(900)	(950)	
	200	(800)	(850)	(900)	(950)	(1000)	(1050)	
	300	(900)	(950)	(1000)	(1050)	(1100)	(1150)	
	400	(1000)	(1050)	(1100)	(1150)	(1200)	(1250)	

**ICSA3-BF HS3M** Cartesian Robot: X-Y-Z 3-Axes Configuration  
Z-Axis Slider Mount Type

**ICSPA3-BF HS3M** Cartesian Robot: X-Y-Z 3-Axes Configuration  
Z-Axis Slider Mount Type High-Precision Specification

Type XYB + Z-Axis Slider Mount Type Stroke X-axis: 1000-2500mm Y-axis: 200-700mm Z-axis: 100-400mm Load capacity 11.9kg - 7.5kg

Model specification items Series Type Encoder type X-axis stroke + options Y-axis stroke + options Z-axis stroke + options Applicable controller Cable length Cable management  
(Example) ICSA3 (ICSPA3) - BF1HS3M - A - 100AQL - 40AQL - 30BLNM - T1 - 5L - CT - SC

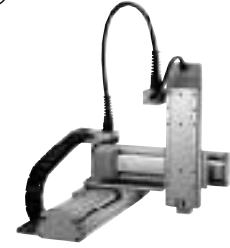

\* Refer to page 51 for the details of model specification items.

**Models/Specifications** \* [ ] is for the high-precision specification.

Encoder Type	XY-axis configuration direction (*1)	Z-axis type (*2)	Model
Absolute	1	M	ICSA3 [ICSPA3] -BF1HS3M-A-①-②-③-BNM-T1-④-⑤
	2	M	ICSA3 [ICSPA3] -BF2HS3M-A-①-②-③-BNM-T1-④-⑤
	3	M	ICSA3 [ICSPA3] -BF3HS3M-A-①-②-③-BNM-T1-④-⑤
	4	M	ICSA3 [ICSPA3] -BF4HS3M-A-①-②-③-BNM-T1-④-⑤
Incremental	1	M	ICSA3 [ICSPA3] -BF1HS3M-I-①-②-③-BNM-T1-④-⑤
	2	M	ICSA3 [ICSPA3] -BF2HS3M-I-①-②-③-BNM-T1-④-⑤
	3	M	ICSA3 [ICSPA3] -BF3HS3M-I-①-②-③-BNM-T1-④-⑤
	4	M	ICSA3 [ICSPA3] -BF4HS3M-I-①-②-③-BNM-T1-④-⑤

\*1: Refer to the figure below for XY-axis configuration direction.  
\*2: The load capacity and the maximum speed may vary depending on the type of Z-axis.  
Note: T1 in the above models will be T2 when operated with XSEL-P/Q type.

**Explanation of Model Code**

Number	Contents	Specification
①	X-axis stroke (Note 1)	100 : 1000mm ~ 250 : 2500mm
②	Y-axis stroke (Note 1)	20 : 200mm ~ 70 : 700mm
③	Z-axis stroke (Note 1)	10 : 100mm ~ 40 : 400mm
④	Cable length (Note 2)	3L : 3m ~ 5L : 5m
⑤	Y-axis/ Z-axis cable management	CT-SC : Self-standing cable (*3)

\* The above explains the Models/Specifications chart to the left.  
\*3 Only cable track can be specified for the Y-axis cable management with model # BF□HS3□.

**Options**

Please add the option codes at the end of each stroke of the axis. When adding multiple options, put together in alphabetic order.

Name	Code	Page
AQ seal	AQ	→P13
Brake	B	→P13
Creep sensor	C	→P13
Home limit switch	L	→P14
Reversed-home specification	NM	→P14
Guide with ball-retaining mechanism	RT	→P14

**Configuration Direction**

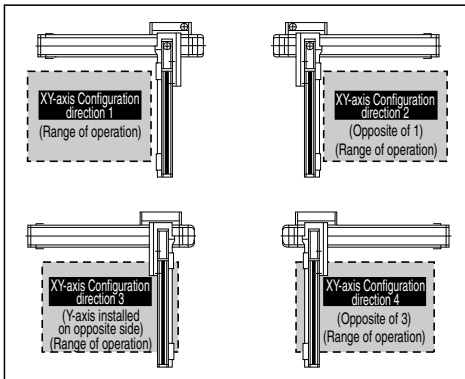

**Common Specifications** \* [ ] is for the high-precision specification.

Drive system	Ball screw, rolled C10 [equivalent to rolled C5]
Positioning repeatability	±0.02mm [±0.01mm]
Backlash	0.05mm or less [0.02mm or less]
Guide	Integrated with base
Base	Material: Aluminum with white alumite treatment
X-axis motor output / lead	400W / 20mm
Y-axis motor output / lead	200W / 20mm
Z-axis motor output / lead	200W / 10mm

**Applicable Controller Specifications**

Refer to page 65 for System Configuration.

**Axis Configuration** \* [ ] is for the high-precision specification.

Axis Type	Model	Page
X-axis	ISA[ISPA]-LXMX-□-400-20-(Stroke)-T1	→P28
Y-axis	ISA[ISPA]-MYM-□-200-20-(Stroke)-T1	→P22
Z-axis	ISA[ISPA]-MZM-□-200-10-(Stroke)-T1-B-NM	→P24

\*In the above model name, □ indicates encoder type A (absolute) or I (incremental).

**Caution**

(Note 1) The stroke in the model is specified in cm (centimeters).  
 (Note 2) The cable length measures from the X-axis connector box to the controller. The standard lengths are 3m and 5m, but other lengths can also be specified in meters. The maximum length is 20m.  
 (Note 3) The rated acceleration is 0.3G. Increasing the acceleration will result in lower load capacity.  
 (Note 4) Please note that a longer stroke will result in a lower maximum speed.

\* For other points to note, please refer to page 49.

**ICSA3 [ICSPA3] -BF□HS3M**

**Load Capacity (kg) (Note3)**

**BF□HS3M**

		Y-axis stroke					
		200	300	400	500	600	700
Z-axis stroke	100	11.9					10.5
	200	10.9					9.5
	300	9.9					8.5
	400	8.9					7.5

**Maximum Speed by Stroke (mm/sec) (Note4)**

**BF□HS3M**

	Stroke														
	100	200~400	500~700	1000~1400	1500	1600	1700	1800	1900	2000	2100	2200	2300	2400	2500
X-axis	-	-	-	1000	950	830	740	650	590	540	490	440	410	370	300
Y-axis	-	1000			-	-	-	-	-	-	-	-	-	-	-
Z-axis	500		-	-	-	-	-	-	-	-	-	-	-	-	-

**Dimensions**

\* The dimension below is for XY-axis Configuration direction 1.

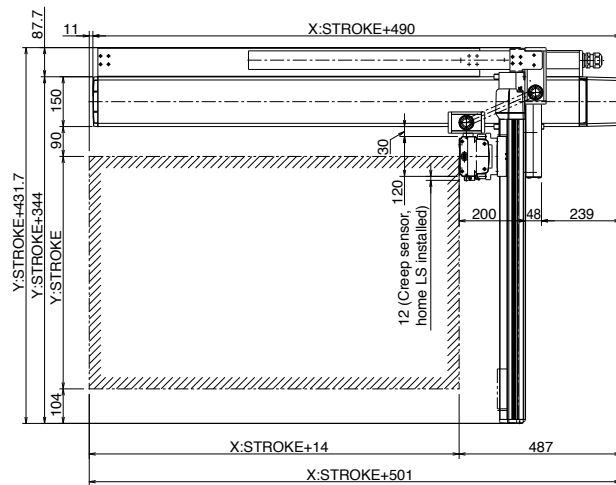
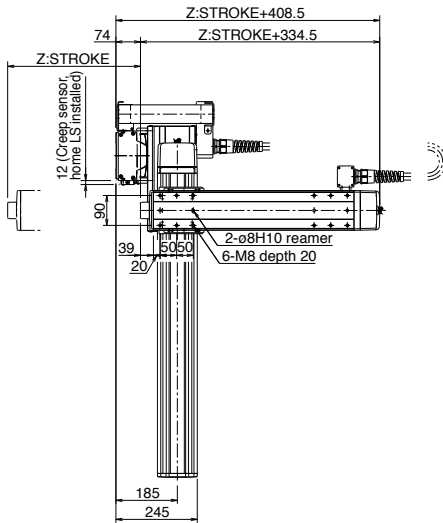

\* The configuration position in the figure is home position. To change the home position, indicate NM in the option. Note that changing the home direction will require the actuator to be returned to IAI for adjustment.

X st	A	B	C	D
1000	225	0	0	12
1100	275	0	0	12
1200	325	0	0	12
1300	375	0	0	12
1400	425	0	0	12
1500	475	0	0	12
1600	525	0	0	12
1700	575	0	0	12
1800	200	425	0	16
1900	200	475	0	16
2000	200	525	0	16
2100	200	575	0	16
2200	200	200	425	20
2300	200	200	475	20
2400	200	200	525	20
2500	200	200	575	20

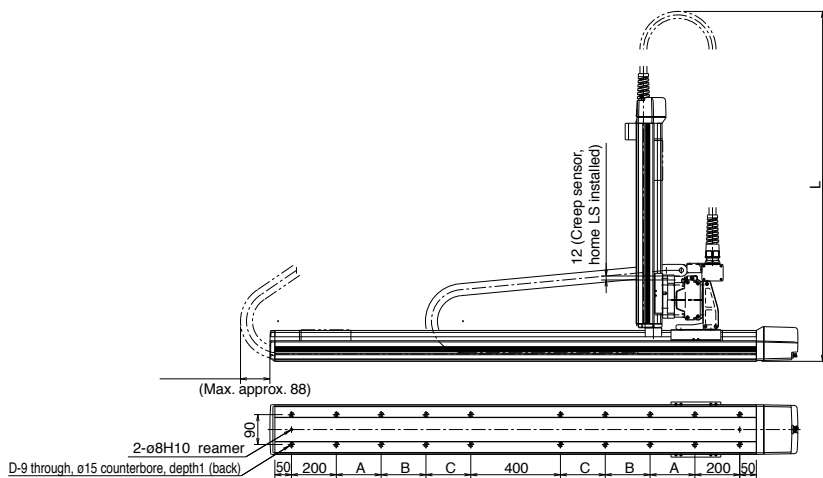

		Y stroke					
		200	300	400	500	600	700
Z stroke	100	(680)	(730)	(780)	(830)	(880)	(930)
	200	(780)	(830)	(880)	(930)	(980)	(1030)
	300	(880)	(930)	(980)	(1030)	(1080)	(1130)
	400	(980)	(1030)	(1080)	(1130)	(1180)	(1230)

<b>ICSA3-G1JHB1</b>		Cartesian Robot: X-Y-Z 3-Axes Configuration Z-Axis Base Mount Type	
<b>ICSPA3-G1JHB1</b>		Cartesian Robot: X-Y-Z 3-Axes Configuration Z-Axis Base Mount Type <b>High-Precision Specification</b>	
Type	XYG + Z-Axis Base Mount Type	Stroke	X-axis: 1000-2500mm Y-axis: 500-700mm Z-axis: 100-600mm
		Load capacity	14kg ~ 3kg
Model specification items	Series	Type	Encoder type
(Example)	ICSA3 (ICSPA3)	G1JHB1H	A
			- 100AQL - 50AQL - 30BL - T1 - 5L - CT - SC

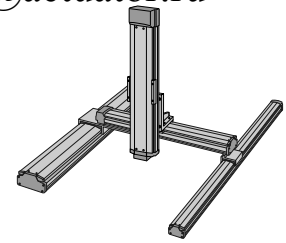

\* Refer to page 51 for the details of model specification items.

**Models/Specifications**

\* [ ] is for the high-precision specification.

Encoder Type	XY-axis configuration direction	Z-axis type (*1)	Model
Absolute	-	H	ICSA3 [ICSPA3] -G1JHB1H-A- [1] - [2] - [3] -B-T1- [4] - [5]
		M	ICSA3 [ICSPA3] -G1JHB1M-A- [1] - [2] - [3] -B-T1- [4] - [5]
		L	ICSA3 [ICSPA3] -G1JHB1L-A- [1] - [2] - [3] -B-T1- [4] - [5]
Incremental	-	H	ICSA3 [ICSPA3] -G1JHB1H-I- [1] - [2] - [3] -B-T1- [4] - [5]
		M	ICSA3 [ICSPA3] -G1JHB1M-I- [1] - [2] - [3] -B-T1- [4] - [5]
		L	ICSA3 [ICSPA3] -G1JHB1L-I- [1] - [2] - [3] -B-T1- [4] - [5]

\*1: The load capacity and the maximum speed may vary depending on the type of Z-axis.  
Note: T1 in the above models will be T2 when operated with XSEL-P/Q type.

**Explanation of Model Code**

Number	Contents	Specification
①	X-axis stroke (Note 1)	100 : 1000mm ~ 250 : 2500mm
②	Y-axis stroke (Note 1)	50 : 500mm ~ 70 : 700mm
③	Z-axis stroke (Note 1)	10 : 100mm ~ 60 : 600mm
④	Cable length (Note 2)	3L : 3m 5L : 5m
⑤	Y-axis/ Z-axis cable management	CT-SC : Self-standing cable (*2) CT-CT : Cable track

\* The above explains the Models/Specifications chart to the left.  
\*2 Only cable track can be specified for the Y-axis cable management with model # G1JHB1□.

**Options**

Please add the option codes at the end of each stroke of the axis.  
When adding multiple options, put together in alphabetic order.

Name	Code	Page
AQ seal	AQ	→P13
Brake	B	→P13
Creep sensor	C	→P13
Home limit switch	L	→P14
Reversed-home specification	NM	→P14
Guide with ball-retaining mechanism	RT	→P14

**Common Specifications**

\* [ ] is for the high-precision specification.

Drive system	Ball screw, rolled C10 [equivalent to rolled C5]
Positioning repeatability	±0.02mm [±0.01mm]
Backlash	0.05mm or less [0.02mm or less]
Guide	Integrated with base
Base	Material: Aluminum with white alumite treatment
X-axis motor output / lead	400W / 20mm
Y-axis motor output / lead	200W / 20mm
Z-axis motor output / lead	60W / 16mm (H), 8mm (M), 4mm (L)

**Applicable Controller Specifications**

Refer to page 65 for System Configuration.

**Axis Configuration**

\* [ ] is for the high-precision specification.

Axis Type	Model	Page
X-axis	ISA[ISPA]-LXUWX-□-400-20-(Stroke)-T1	→P30
Y-axis	ISA[ISPA]-MXM-□-200-20-(Stroke)-T1	→P19
Z-axis	ISA[ISPA]-SXM-□-60-16/8/4-(Stroke)-T1-B	→P15

\*In the above model name, □ indicates encoder type A (absolute) or I (incremental).

**Caution**

(Note 1) The stroke in the model is specified in cm (centimeters).  
 (Note 2) The cable length measures from the X-axis connector box to the controller. The standard lengths are 3m and 5m, but other lengths can also be specified in meters. The maximum length is 20m.  
 (Note 3) The rated acceleration is 0.3G. Increasing the acceleration will result in lower load capacity.  
 (Note 4) Please note that a longer stroke will result in a lower maximum speed.

\* For other points to note, please refer to page 49.

ICSA3 [ICSPA3] -G1JHB1□

Single-Axis Robots  
Cartesian Robots  
Controllers

Load Capacity (kg) (Note3)

G1JHB1H

		Y-axis stroke		
		500	600	700
Z-axis stroke	100	3.0		
	200	3.0		
	300	3.0		
	400	3.0		
	500	3.0		
	600	3.0		

G1JHB1M

		Y-axis stroke		
		500	600	700
Z-axis stroke	100	6.0		
	200	6.0		
	300	6.0		
	400	6.0		
	500	6.0		
	600	6.0		

G1JHB1L

		Y-axis stroke		
		500	600	700
Z-axis stroke	100	14.0		
	200	14.0		
	300	14.0		
	400	14.0		
	500	14.0		
	600	14.0		

Maximum Speed by Stroke (mm/sec) (Note4)

G1JHB1H

	Stroke															
	100~400	500	600	700	1000~1400	1500	1600	1700	1800	1900	2000	2100	2200	2300	2400	2500
X-axis	-	-	-	-	1000	950	830	740	650	590	540	490	440	410	370	300
Y-axis	1000				-	-	-	-	-	-	-	-	-	-	-	-
Z-axis	800				-	-	-	-	-	-	-	-	-	-	-	-

G1JHB1M

	Stroke															
	100~400	500	600	700	1000~1400	1500	1600	1700	1800	1900	2000	2100	2200	2300	2400	2500
X-axis	-	-	-	-	1000	950	830	740	650	590	540	490	440	410	370	300
Y-axis	1000				-	-	-	-	-	-	-	-	-	-	-	-
Z-axis	400				-	-	-	-	-	-	-	-	-	-	-	-

G1JHB1L

	Stroke															
	100~400	500	600	700	1000~1400	1500	1600	1700	1800	1900	2000	2100	2200	2300	2400	2500
X-axis	-	-	-	-	1000	950	830	740	650	590	540	490	440	410	370	300
Y-axis	1000				-	-	-	-	-	-	-	-	-	-	-	-
Z-axis	200				-	-	-	-	-	-	-	-	-	-	-	-

Dimensions

\* The configuration position in the figure is home position.  
To change the home position, indicate NM in the option.  
Note that changing the home direction will require the actuator to be returned to IAI for adjustment.

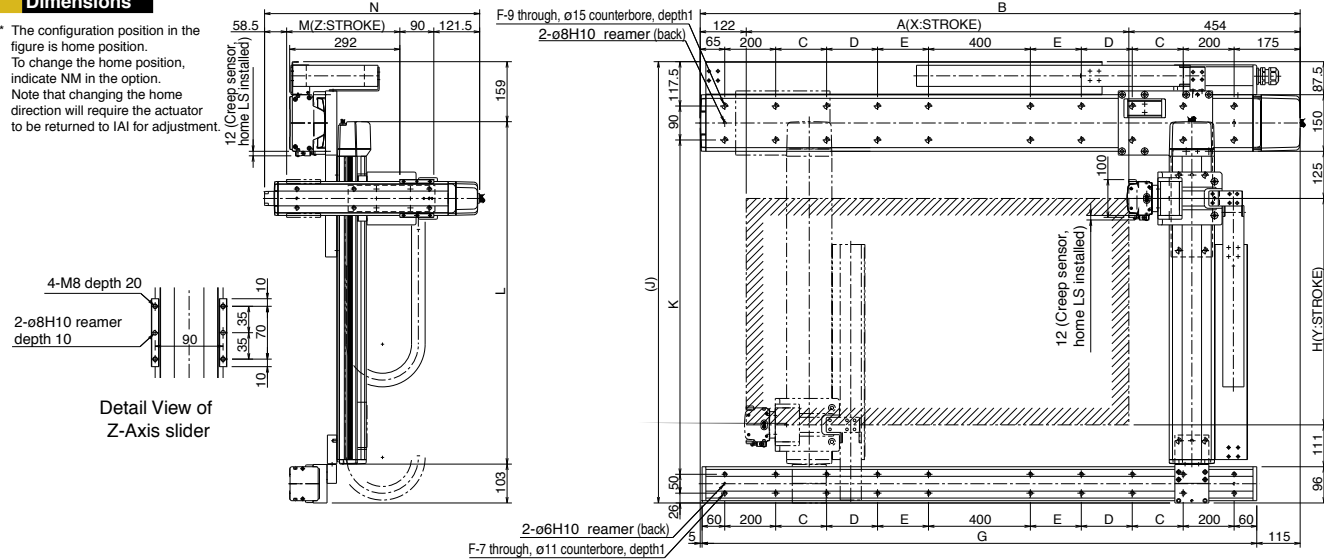

X dimension

A	B	C	D	E	F	G
1014	1590	275	0	0	12	1470
1114	1690	325	0	0	12	1570
1214	1790	375	0	0	12	1670
1314	1890	425	0	0	12	1770
1414	1990	475	0	0	12	1870
1514	2090	525	0	0	12	1970
1614	2190	575	0	0	12	2070
1714	2290	200	425	0	16	2170
1814	2390	200	475	0	16	2270
1914	2490	200	525	0	16	2370
2014	2590	200	575	0	16	2470
2114	2690	200	200	425	20	2570
2214	2790	200	200	475	20	2670
2314	2890	200	200	525	20	2770
2414	2990	200	200	575	20	2870
2514	3090	200	200	625	20	2970

Y dimension

H	J	K	L
500	1069.5	786	807.5
600	1169.5	886	907.5
700	1269.5	986	1007.5

Z dimension

M	N
100	370
200	470
300	570
400	670
500	770
600	870

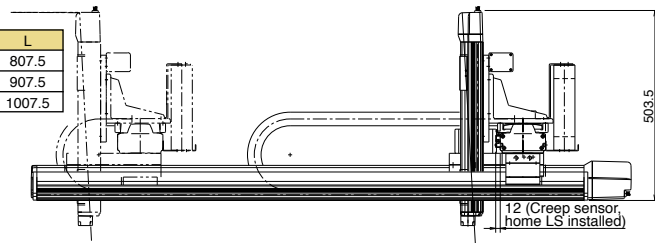

<b>ICSA3-G1JHB2</b> □		Cartesian Robot: X-Y-Z 3-Axes Configuration Z-Axis Base Mount Type
<b>ICSPA3-G1JHB2</b> □		Cartesian Robot: X-Y-Z 3-Axes Configuration Z-Axis Base Mount Type <b>High-Precision Specification</b>
Type	XYG + Z-Axis Base Mount Type	Stroke X-axis: 1000-2500mm Y-axis: 500-700mm Z-axis: 100-600mm
Load capacity		19kg ~ 3.5kg
Model specification items	Series	Type Encoder type X-axis stroke + options Y-axis stroke + options Z-axis stroke + options Applicable controller Cable length Cable management
(Example)	ICSA3 (ICSPA3)	G1JHB2H-A 100AQL 50AQL 30BL T1 5L CT-SC

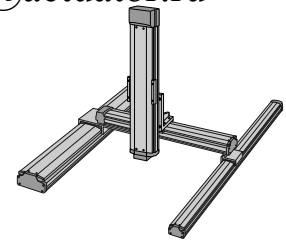

\* Refer to page 51 for the details of model specification items.

**Models/Specifications**

\* [ ] is for the high-precision specification.

Encoder Type	XY-axis configuration direction	Z-axis type (*1)	Model
Absolute	-	H	ICSA3 [ICSPA3] -G1JHB2H-A- ① - ② - ③ -B-T1- ④ - ⑤
		M	ICSA3 [ICSPA3] -G1JHB2M-A- ① - ② - ③ -B-T1- ④ - ⑤
		L	ICSA3 [ICSPA3] -G1JHB2L-A- ① - ② - ③ -B-T1- ④ - ⑤
Incremental	-	H	ICSA3 [ICSPA3] -G1JHB2H-I- ① - ② - ③ -B-T1- ④ - ⑤
		M	ICSA3 [ICSPA3] -G1JHB2M-I- ① - ② - ③ -B-T1- ④ - ⑤
		L	ICSA3 [ICSPA3] -G1JHB2L-I- ① - ② - ③ -B-T1- ④ - ⑤

\*1: The load capacity and the maximum speed may vary depending on the type of Z-axis.  
Note: T1 in the above models will be T2 when operated with XSEL-P/Q type.

**Explanation of Model Code**

Number	Contents	Specification
①	X-axis stroke (Note 1)	100 : 1000mm ~ 250 : 2500mm
②	Y-axis stroke (Note 1)	50 : 500mm ~ 70 : 700mm
③	Z-axis stroke (Note 1)	10 : 100mm ~ 60 : 600mm
④	Cable length (Note 2)	3L : 3m 5L : 5m
⑤	Y-axis/ Z-axis cable management	CT-SC : Self-standing cable (*2) CT-CT : Cable track

\* The above explains the Models/Specifications chart to the left.  
\*2 Only cable track can be specified for the Y-axis cable management with model # G1JHB2□.

**Options**

Please add the option codes at the end of each stroke of the axis.  
When adding multiple options, put together in alphabetic order.

Name	Code	Page
AQ seal	AQ	→P13
Brake	B	→P13
Creep sensor	C	→P13
Home limit switch	L	→P14
Reversed-home specification	NM	→P14
Guide with ball-retaining mechanism	RT	→P14

**Common Specifications**

\* [ ] is for the high-precision specification.

Drive system	Ball screw, rolled C10 [equivalent to rolled C5]
Positioning repeatability	±0.02mm [±0.01mm]
Backlash	0.05mm or less [0.02mm or less]
Guide	Integrated with base
Base	Material: Aluminum with white alumite treatment
X-axis motor output / lead	400W / 20mm
Y-axis motor output / lead	200W / 20mm
Z-axis motor output / lead	100W / 20mm (H), 10mm (M), 5mm (L)

**Applicable Controller Specifications**

Refer to page 65 for System Configuration.

**Axis Configuration**

\* [ ] is for the high-precision specification.

Axis Type	Model	Page
X-axis	ISA[ISPA]-LXUWX-□-400-20-(Stroke)-T1	→P30
Y-axis	ISA[ISPA]-MXM-□-200-20-(Stroke)-T1	→P19
Z-axis	ISA[ISPA]-MXM-□-100-20/10/5-(Stroke)-T1-B	→P18

\*In the above model name, □ indicates encoder type A (absolute) or I (incremental).

**Caution**

(Note 1) The stroke in the model is specified in cm (centimeters).  
 (Note 2) The cable length measures from the X-axis connector box to the controller. The standard lengths are 3m and 5m, but other lengths can also be specified in meters. The maximum length is 20m.  
 (Note 3) The rated acceleration is 0.3G. Increasing the acceleration will result in lower load capacity.  
 (Note 4) Please note that a longer stroke will result in a lower maximum speed.

\* For other points to note, please refer to page 49.

ICSA3 [ICSPA3] -G1JHB2□

Load Capacity (kg) (Note3)

G1JHB2H

		Y-axis stroke		
		500	600	700
Z-axis stroke	100	3.5		
	200	3.5		
	300	3.5		
	400	3.5		
	500	3.5		
	600	3.5		

G1JHB2M

		Y-axis stroke		
		500	600	700
Z-axis stroke	100	9.0		
	200	9.0		
	300	9.0		
	400	9.0		
	500	9.0		
	600	9.0		

G1JHB2L

		Y-axis stroke		
		500	600	700
Z-axis stroke	100	19.0		
	200	19.0		
	300	19.0		
	400	19.0		
	500	18.8		
	600	17.8		

Maximum Speed by Stroke (mm/sec) (Note4)

G1JHB2H

	Stroke															
	100~400	500	600	700	1000~1400	1500	1600	1700	1800	1900	2000	2100	2200	2300	2400	2500
X-axis	-	-	-	-	1000	950	830	740	650	590	540	490	440	410	370	300
Y-axis	1000				-	-	-	-	-	-	-	-	-	-	-	-
Z-axis	1000				-	-	-	-	-	-	-	-	-	-	-	-

G1JHB2M

	Stroke															
	100~400	500	600	700	1000~1400	1500	1600	1700	1800	1900	2000	2100	2200	2300	2400	2500
X-axis	-	-	-	-	1000	950	830	740	650	590	540	490	440	410	370	300
Y-axis	1000				-	-	-	-	-	-	-	-	-	-	-	-
Z-axis	500				-	-	-	-	-	-	-	-	-	-	-	-

G1JHB2L

	Stroke															
	100~400	500	600	700	1000~1400	1500	1600	1700	1800	1900	2000	2100	2200	2300	2400	2500
X-axis	-	-	-	-	1000	950	830	740	650	590	540	490	440	410	370	300
Y-axis	1000				-	-	-	-	-	-	-	-	-	-	-	-
Z-axis	250				-	-	-	-	-	-	-	-	-	-	-	-

Dimensions

\* The configuration position in the figure is home position.  
To change the home position, indicate NM in the option.  
Note that changing the home direction will require the actuator to be returned to IAI for adjustment.

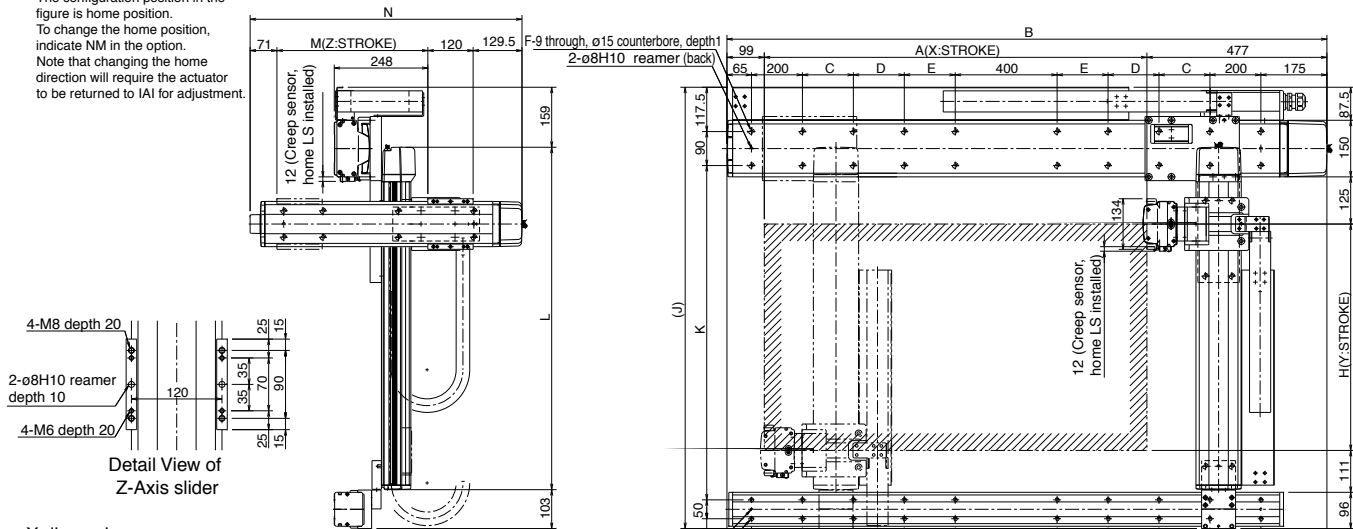

X dimension

A	B	C	D	E	F	G
1014	1590	275	0	0	12	1470
1114	1690	325	0	0	12	1570
1214	1790	375	0	0	12	1670
1314	1890	425	0	0	12	1770
1414	1990	475	0	0	12	1870
1514	2090	525	0	0	12	1970
1614	2190	575	0	0	12	2070
1714	2290	200	425	0	16	2170
1814	2390	200	475	0	16	2270
1914	2490	200	525	0	16	2370
2014	2590	200	575	0	16	2470
2114	2690	200	200	425	20	2570
2214	2790	200	200	475	20	2670
2314	2890	200	200	525	20	2770
2414	2990	200	200	575	20	2870
2514	3090	200	200	625	20	2970

Y dimension

H	J	K	L
500	1069.5	786	807.5
600	1169.5	886	907.5
700	1269.5	986	1007.5

Z dimension

M	N(100W)	N(200W)
100	420.5	434.5
200	520.5	534.5
300	620.5	634.5
400	720.5	734.5
500	820.5	834.5
600	920.5	934.5

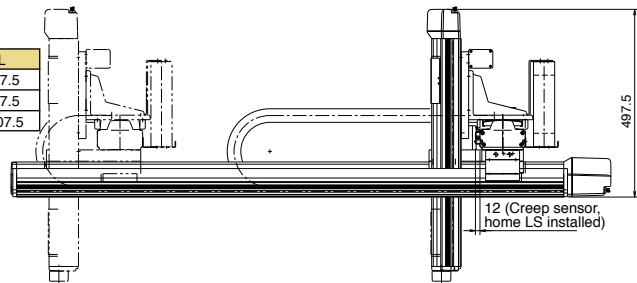

<b>ICSA3-G1JHB3</b>		Cartesian Robot: X-Y-Z 3-Axes Configuration Z-Axis Base Mount Type	
<b>ICSPA3-G1JHB3</b>		Cartesian Robot: X-Y-Z 3-Axes Configuration Z-Axis Base Mount Type <b>High-Precision Specification</b>	
Type	XYG + Z-Axis Base Mount Type	Stroke	X-axis: 1000-2500mm Y-axis: 500-700mm Z-axis: 100-600mm
		Load capacity	19kg ~ 9kg
Model specification items	Series	Type	Encoder type
(Example)	ICSA3 (ICSPA3)	G1JHB3H-	A
			- 100AQL - 50AQL - 30BL - T1 - 5L - CT - SC

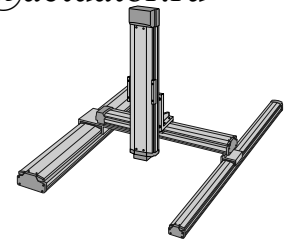

\* Refer to page 51 for the details of model specification items.

**Models/Specifications**

\* [ ] is for the high-precision specification.

Encoder Type	XY-axis configuration direction	Z-axis type (*1)	Model
Absolute	-	H	ICSA3 [ICSPA3] -G1JHB3H-A- [1] - [2] - [3] -B-T1- [4] - [5]
		M	ICSA3 [ICSPA3] -G1JHB3M-A- [1] - [2] - [3] -B-T1- [4] - [5]
		L	ICSA3 [ICSPA3] -G1JHB3L-A- [1] - [2] - [3] -B-T1- [4] - [5]
Incremental	-	H	ICSA3 [ICSPA3] -G1JHB3H-I- [1] - [2] - [3] -B-T1- [4] - [5]
		M	ICSA3 [ICSPA3] -G1JHB3M-I- [1] - [2] - [3] -B-T1- [4] - [5]
		L	ICSA3 [ICSPA3] -G1JHB3L-I- [1] - [2] - [3] -B-T1- [4] - [5]

\*1: The load capacity and the maximum speed may vary depending on the type of Z-axis.  
Note: T1 in the above models will be T2 when operated with XSEL-P/Q type.

**Explanation of Model Code**

Number	Contents	Specification
[1]	X-axis stroke (Note 1)	100 : 1000mm ~ 250 : 2500mm
[2]	Y-axis stroke (Note 1)	50 : 500mm ~ 70 : 700mm
[3]	Z-axis stroke (Note 1)	10 : 100mm ~ 60 : 600mm
[4]	Cable length (Note 2)	3L : 3m 5L : 5m
[5]	Y-axis/ Z-axis cable management	CT-SC : Self-standing cable (*2) CT-CT : Cable track

\* The above explains the Models/Specifications chart to the left.  
\*2 Only cable track can be specified for the Y-axis cable management with model # G1JHB3□.

**Options**

Please add the option codes at the end of each stroke of the axis.  
When adding multiple options, put together in alphabetic order.

Name	Code	Page
AQ seal	AQ	→P13
Brake	B	→P13
Creep sensor	C	→P13
Home limit switch	L	→P14
Reversed-home specification	NM	→P14
Guide with ball-retaining mechanism	RT	→P14

**Common Specifications**

\* [ ] is for the high-precision specification.

Drive system	Ball screw, rolled C10 [equivalent to rolled C5]
Positioning repeatability	±0.02mm [±0.01mm]
Backlash	0.05mm or less [0.02mm or less]
Guide	Integrated with base
Base	Material: Aluminum with white alumite treatment
X-axis motor output / lead	400W / 20mm
Y-axis motor output / lead	200W / 20mm
Z-axis motor output / lead	200W / 20mm (H), 10mm (M)

**Applicable Controller Specifications**

Refer to page 65 for System Configuration.

**Axis Configuration**

\* [ ] is for the high-precision specification.

Axis Type	Model	Page
X-axis	ISA[ISPA]-LXUWX-□-400-20-(Stroke)-T1	→P30
Y-axis	ISA[ISPA]-MXM-□-200-20-(Stroke)-T1	→P19
Z-axis	ISA[ISPA]-MXM-□-200-20/10-(Stroke)-T1-B	→P19

\*In the above model name, □ indicates encoder type A (absolute) or I (incremental).

**Caution**

(Note 1) The stroke in the model is specified in cm (centimeters).  
 (Note 2) The cable length measures from the X-axis connector box to the controller. The standard lengths are 3m and 5m, but other lengths can also be specified in meters. The maximum length is 20m.  
 (Note 3) The rated acceleration is 0.3G. Increasing the acceleration will result in lower load capacity.  
 (Note 4) Please note that a longer stroke will result in a lower maximum speed.

\* For other points to note, please refer to page 49.



ICSA3 [ICSPA3] -G1JHB3□

Load Capacity (kg) (Note3)

G1JHB3H

		Y-axis stroke		
		500	600	700
Z-axis stroke	100	9.0		
	200	9.0		
	300	9.0		
	400	9.0		
	500	9.0		
	600	9.0		

G1JHB3M

		Y-axis stroke		
		500	600	700
Z-axis stroke	100	19.0		
	200	19.0		
	300	19.0		
	400	18.7		
	500	17.6		
	600	16.6		

Maximum Speed by Stroke (mm/sec) (Note4)

G1JHB3H

	Stroke															
	100~400	500	600	700	1000~1400	1500	1600	1700	1800	1900	2000	2100	2200	2300	2400	2500
X-axis	-	-	-	-	1000	950	830	740	650	590	540	490	440	410	370	300
Y-axis	-	1000			-	-	-	-	-	-	-	-	-	-	-	-
Z-axis	1000			-	-	-	-	-	-	-	-	-	-	-	-	-

G1JHB3M

	Stroke															
	100~400	500	600	700	1000~1400	1500	1600	1700	1800	1900	2000	2100	2200	2300	2400	2500
X-axis	-	-	-	-	1000	950	830	740	650	590	540	490	440	410	370	300
Y-axis	-	1000			-	-	-	-	-	-	-	-	-	-	-	-
Z-axis	500			-	-	-	-	-	-	-	-	-	-	-	-	-

Dimensions

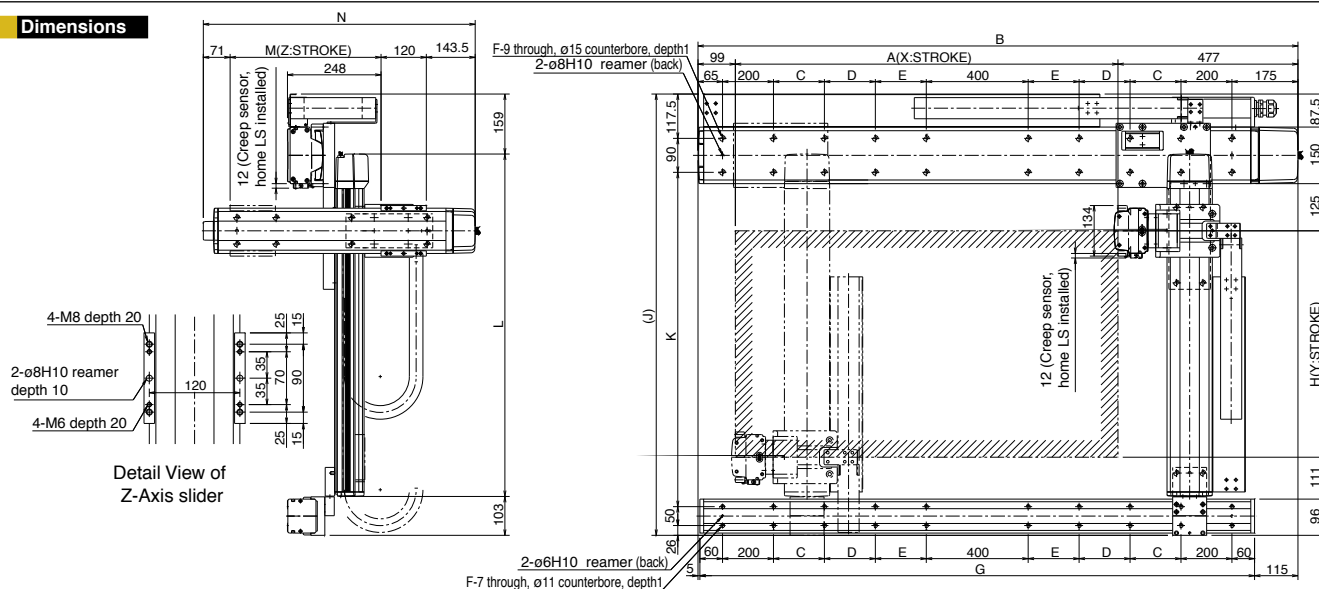

\* The configuration position in the figure is home position. To change the home position, indicate NM in the option. Note that changing the home direction will require the actuator to be returned to IAI for adjustment.

X dimension

A	B	C	D	E	F	G
1014	1590	275	0	0	12	1470
1114	1690	325	0	0	12	1570
1214	1790	375	0	0	12	1670
1314	1890	425	0	0	12	1770
1414	1990	475	0	0	12	1870
1514	2090	525	0	0	12	1970
1614	2190	575	0	0	12	2070
1714	2290	200	425	0	16	2170
1814	2390	200	475	0	16	2270
1914	2490	200	525	0	16	2370
2014	2590	200	575	0	16	2470
2114	2690	200	200	425	20	2570
2214	2790	200	200	475	20	2670
2314	2890	200	200	525	20	2770
2414	2990	200	200	575	20	2870
2514	3090	200	200	625	20	2970

Y dimension

H	J	K	L
500	1069.5	786	807.5
600	1169.5	886	907.5
700	1269.5	986	1007.5

Z dimension

M	N(100W)	N(200W)
100	420.5	434.5
200	520.5	534.5
300	620.5	634.5
400	720.5	734.5
500	820.5	834.5
600	920.5	934.5

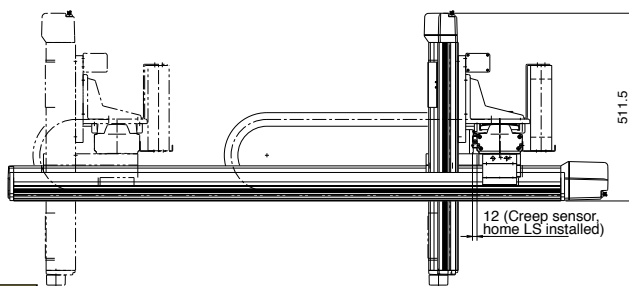

<b>ICSA3-G2JHB1</b> □		Cartesian Robot: X-Y-Z 3-Axes Configuration Z-Axis Base Mount Type
<b>ICSPA3-G2JHB1</b> □		Cartesian Robot: X-Y-Z 3-Axes Configuration Z-Axis Base Mount Type <b>High-Precision Specification</b>
Type	XYG + Z-Axis Base Mount Type	Stroke X-axis: 1000-2500mm Y-axis: 800-1200mm Z-axis: 100-600mm
Load capacity		14kg ~ 3kg
Model specification items	Series	Type Encoder type X-axis stroke + options Y-axis stroke + options Z-axis stroke + options Applicable controller Cable length Cable management
(Example)	ICSA3 (ICSPA3)	G2JHB1H-A 100AQL 80AQL 30BL T1 5L CT-SC

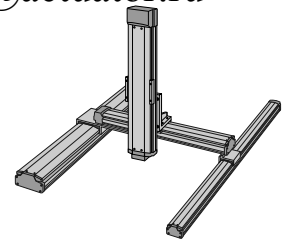

\* Refer to page 51 for the details of model specification items.

**Models/Specifications**

\* [ ] is for the high-precision specification.

Encoder Type	XY-axis configuration direction	Z-axis type (*1)	Model
Absolute	-	H	ICSA3 [ICSPA3] -G2JHB1H-A-①-②-③-B-T1-④-⑤
		M	ICSA3 [ICSPA3] -G2JHB1M-A-①-②-③-B-T1-④-⑤
		L	ICSA3 [ICSPA3] -G2JHB1L-A-①-②-③-B-T1-④-⑤
Incremental	-	H	ICSA3 [ICSPA3] -G2JHB1H-I-①-②-③-B-T1-④-⑤
		M	ICSA3 [ICSPA3] -G2JHB1M-I-①-②-③-B-T1-④-⑤
		L	ICSA3 [ICSPA3] -G2JHB1L-I-①-②-③-B-T1-④-⑤

\*1: The load capacity and the maximum speed may vary depending on the type of Z-axis.  
Note: T1 in the above models will be T2 when operated with XSEL-P/Q type.

**Explanation of Model Code**

Number	Contents	Specification
①	X-axis stroke (Note 1)	100 : 1000mm ~ 250 : 2500mm
②	Y-axis stroke (Note 1)	80 : 800mm ~ 120 : 1200mm
③	Z-axis stroke (Note 1)	10 : 100mm ~ 60 : 600mm
④	Cable length (Note 2)	3L : 3m 5L : 5m
⑤	Y-axis/ Z-axis cable management	CT-SC : Self-standing cable (*2) CT-CT : Cable track

\* The above explains the Models/Specifications chart to the left.  
\*2 Only cable track can be specified for the Y-axis cable management with model # G2JHB1□.

**Options**

Please add the option codes at the end of each stroke of the axis.  
When adding multiple options, put together in alphabetic order.

Name	Code	Page
AQ seal	AQ	→P13
Brake	B	→P13
Creep sensor	C	→P13
Home limit switch	L	→P14
Reversed-home specification	NM	→P14
Guide with ball-retaining mechanism	RT	→P14

**Common Specifications**

\* [ ] is for the high-precision specification.

Drive system	Ball screw, rolled C10 [equivalent to rolled C5]
Positioning repeatability	±0.02mm [±0.01mm]
Backlash	0.05mm or less [0.02mm or less]
Guide	Integrated with base
Base	Material: Aluminum with white alumite treatment
X-axis motor output / lead	400W / 20mm
Y-axis motor output / lead	200W / 20mm
Z-axis motor output / lead	60W / 16mm (H), 8mm (M), 4mm (L)

**Applicable Controller Specifications**

Refer to page 65 for System Configuration.

**Axis Configuration**

\* [ ] is for the high-precision specification.

Axis Type	Model	Page
X-axis	ISA[ISPA]-LXUWX-□-400-20-(Stroke)-T1	→P30
Y-axis	ISA[ISPA]-MXMX-□-200-20-(Stroke)-T1	→P20
Z-axis	ISA[ISPA]-SXM-□-60-16/8/4-(Stroke)-T1-B	→P15

\*In the above model name, □ indicates encoder type A (absolute) or I (incremental).

**Caution**

(Note 1) The stroke in the model is specified in cm (centimeters).  
 (Note 2) The cable length measures from the X-axis connector box to the controller. The standard lengths are 3m and 5m, but other lengths can also be specified in meters. The maximum length is 20m.  
 (Note 3) The rated acceleration is 0.3G. Increasing the acceleration will result in lower load capacity.  
 (Note 4) Please note that a longer stroke will result in a lower maximum speed.

\* For other points to note, please refer to page 49.

ICSA3 [ICSPA3] -G2JHB1□

Load Capacity (kg) (Note3)

G2JHB1H

		Y-axis stroke				
		800	900	1000	1100	1200
Z-axis stroke	100	3.0				
	200	3.0				
	300	3.0				
	400	3.0				
	500	3.0				
	600	3.0				

G2JHB1M

		Y-axis stroke				
		800	900	1000	1100	1200
Z-axis stroke	100	6.0				
	200	6.0				
	300	6.0				
	400	6.0				
	500	6.0				
	600	6.0				

G2JHB1L

		Y-axis stroke				
		800	900	1000	1100	1200
Z-axis stroke	100	14.0				
	200	14.0				
	300	14.0				
	400	14.0				
	500	14.0				
	600	14.0				

Maximum Speed by Stroke (mm/sec) (Note4)

G2JHB1H

	Stroke														
	100~600	800~900	1000~1200	1300~1400	1500	1600	1700	1800	1900	2000	2100	2200	2300	2400	2500
X-axis	-	-	1000		950	830	740	650	590	540	490	440	410	370	300
Y-axis	-	1000		-	-	-	-	-	-	-	-	-	-	-	-
Z-axis	800	-	-	-	-	-	-	-	-	-	-	-	-	-	-

G2JHB1M

	Stroke														
	100~600	800~900	1000~1200	1300~1400	1500	1600	1700	1800	1900	2000	2100	2200	2300	2400	2500
X-axis	-	-	1000		950	830	740	650	590	540	490	440	410	370	300
Y-axis	-	1000		-	-	-	-	-	-	-	-	-	-	-	-
Z-axis	400	-	-	-	-	-	-	-	-	-	-	-	-	-	-

G2JHB1L

	Stroke														
	100~600	800~900	1000~1200	1300~1400	1500	1600	1700	1800	1900	2000	2100	2200	2300	2400	2500
X-axis	-	-	1000		950	830	740	650	590	540	490	440	410	370	300
Y-axis	-	1000		-	-	-	-	-	-	-	-	-	-	-	-
Z-axis	200	-	-	-	-	-	-	-	-	-	-	-	-	-	-

Dimensions

\* The configuration position in the figure is home position. To change the home position, indicate NM in the option. Note that changing the home direction will require the actuator to be returned to IAI for adjustment.

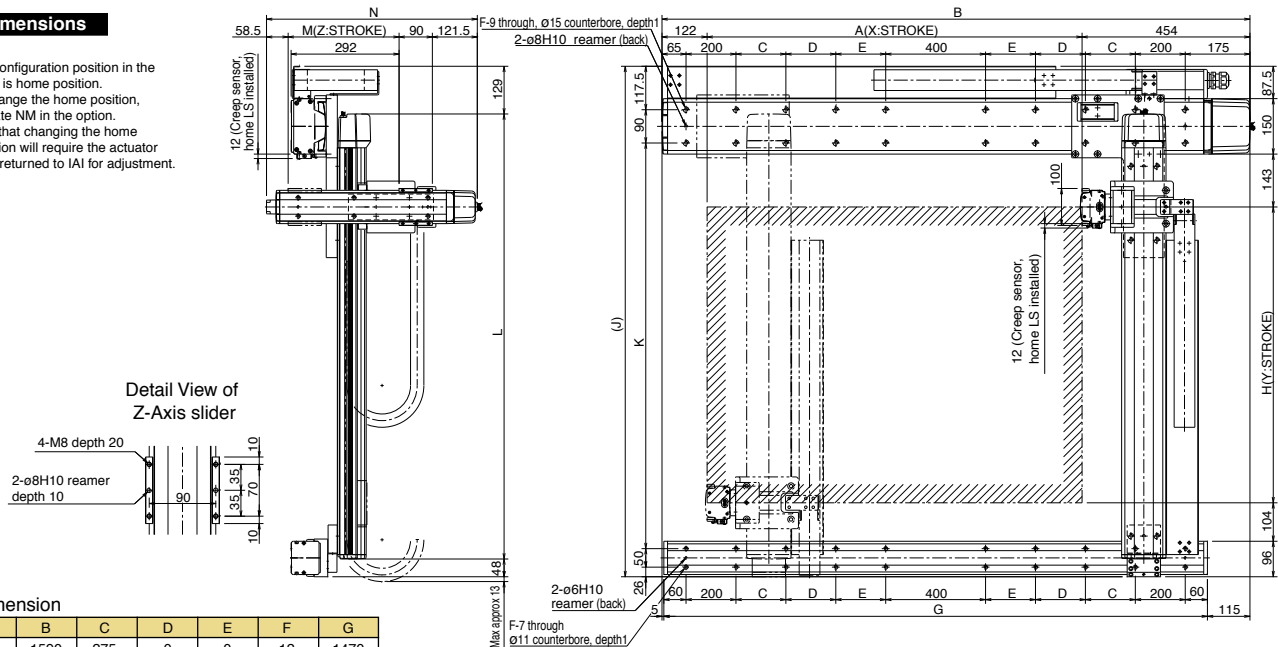

X dimension

A	B	C	D	E	F	G
1014	1590	275	0	0	12	1470
1114	1690	325	0	0	12	1570
1214	1790	375	0	0	12	1670
1314	1890	425	0	0	12	1770
1414	1990	475	0	0	12	1870
1514	2090	525	0	0	12	1970
1614	2190	575	0	0	12	2070
1714	2290	200	425	0	16	2170
1814	2390	200	475	0	16	2270
1914	2490	200	525	0	16	2370
2014	2590	200	575	0	16	2470
2114	2690	200	200	425	20	2570
2214	2790	200	200	475	20	2670
2314	2890	200	200	525	20	2770
2414	2990	200	200	575	20	2870
2514	3090	200	200	625	20	2970

Y dimension

H	J	K	L
800	1380.5	1097	1203.5
900	1480.5	1197	1303.5
1000	1580.5	1297	1403.5
1100	1680.5	1397	1503.5
1200	1780.5	1497	1603.5

Z dimension

M	N
100	370
200	470
300	570
400	670
500	770
600	870

<b>ICSA3-G2JHB2</b> <input type="checkbox"/>		Cartesian Robot: X-Y-Z 3-Axes Configuration Z-Axis Base Mount Type
<b>ICSPA3-G2JHB2</b> <input type="checkbox"/>		Cartesian Robot: X-Y-Z 3-Axes Configuration Z-Axis Base Mount Type <b>High-Precision Specification</b>
Type	XYG + Z-Axis Base Mount Type	Stroke X-axis: 1000-2500mm Y-axis: 800-1200mm Z-axis: 100-600mm
Load capacity		19kg ~ 3.5kg
Model specification items	Series	Type Encoder type X-axis stroke + options Y-axis stroke + options Z-axis stroke + options Applicable controller Cable length Cable management
(Example)	ICSA3 (ICSPA3)	G2JHB2H-A 100AQL 80AQL 30BL T1 5L CT-SC

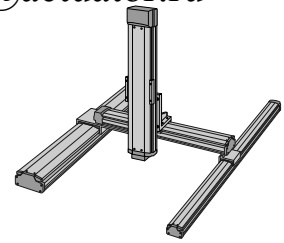

\* Refer to page 51 for the details of model specification items.

**Models/Specifications**

\* [ ] is for the high-precision specification.

Encoder Type	XY-axis configuration direction	Z-axis type (*1)	Model
Absolute	-	H	ICSA3 [ICSPA3] -G2JHB2H-A- <input type="checkbox"/> - <input type="checkbox"/> - <input type="checkbox"/> -B-T1- <input type="checkbox"/> - <input type="checkbox"/>
		M	ICSA3 [ICSPA3] -G2JHB2M-A- <input type="checkbox"/> - <input type="checkbox"/> - <input type="checkbox"/> -B-T1- <input type="checkbox"/> - <input type="checkbox"/>
		L	ICSA3 [ICSPA3] -G2JHB2L-A- <input type="checkbox"/> - <input type="checkbox"/> - <input type="checkbox"/> -B-T1- <input type="checkbox"/> - <input type="checkbox"/>
Incremental	-	H	ICSA3 [ICSPA3] -G2JHB2H-I- <input type="checkbox"/> - <input type="checkbox"/> - <input type="checkbox"/> -B-T1- <input type="checkbox"/> - <input type="checkbox"/>
		M	ICSA3 [ICSPA3] -G2JHB2M-I- <input type="checkbox"/> - <input type="checkbox"/> - <input type="checkbox"/> -B-T1- <input type="checkbox"/> - <input type="checkbox"/>
		L	ICSA3 [ICSPA3] -G2JHB2L-I- <input type="checkbox"/> - <input type="checkbox"/> - <input type="checkbox"/> -B-T1- <input type="checkbox"/> - <input type="checkbox"/>

\*1: The load capacity and the maximum speed may vary depending on the type of Z-axis.  
Note: T1 in the above models will be T2 when operated with XSEL-P/Q type.

**Explanation of Model Code**

Number	Contents	Specification
①	X-axis stroke (Note 1)	100 : 1000mm ~ 250 : 2500mm
②	Y-axis stroke (Note 1)	80 : 800mm ~ 120 : 1200mm
③	Z-axis stroke (Note 1)	10 : 100mm ~ 60 : 600mm
④	Cable length (Note 2)	3L : 3m 5L : 5m
⑤	Y-axis/ Z-axis cable management	CT-SC : Self-standing cable (*2) CT-CT : Cable track

\* The above explains the Models/Specifications chart to the left.  
\*2 Only cable track can be specified for the Y-axis cable management with model # G2JHB2□.

**Options**

Please add the option codes at the end of each stroke of the axis.  
When adding multiple options, put together in alphabetic order.

Name	Code	Page
AQ seal	AQ	→P13
Brake	B	→P13
Creep sensor	C	→P13
Home limit switch	L	→P14
Reversed-home specification	NM	→P14
Guide with ball-retaining mechanism	RT	→P14

**Common Specifications**

\* [ ] is for the high-precision specification.

Drive system	Ball screw, rolled C10 [equivalent to rolled C5]
Positioning repeatability	±0.02mm [±0.01mm]
Backlash	0.05mm or less [0.02mm or less]
Guide	Integrated with base
Base	Material: Aluminum with white alumite treatment
X-axis motor output / lead	400W / 20mm
Y-axis motor output / lead	200W / 20mm
Z-axis motor output / lead	100W / 20mm (H), 10mm (M), 5mm (L)

**Applicable Controller Specifications**

Refer to page 65 for System Configuration.

**Axis Configuration**

\* [ ] is for the high-precision specification.

Axis Type	Model	Page
X-axis	ISA[ISPA]-LXUWX-□-400-20-(Stroke)-T1	→P30
Y-axis	ISA[ISPA]-MXMX-□-200-20-(Stroke)-T1	→P20
Z-axis	ISA[ISPA]-MXM-□-100-20/10/5-(Stroke)-T1-B	→P18

\*In the above model name, □ indicates encoder type A (absolute) or I (incremental).

**Caution**

(Note 1) The stroke in the model is specified in cm (centimeters).  
 (Note 2) The cable length measures from the X-axis connector box to the controller. The standard lengths are 3m and 5m, but other lengths can also be specified in meters. The maximum length is 20m.  
 (Note 3) The rated acceleration is 0.3G. Increasing the acceleration will result in lower load capacity.  
 (Note 4) Please note that a longer stroke will result in a lower maximum speed.

\* For other points to note, please refer to page 49.

ICSA3 [ICSPA3] -G2JHB2□

Load Capacity (kg) (Note3)

G2JHB2H

		Y-axis stroke				
		800	900	1000	1100	1200
Z-axis stroke	100	3.5				
	200	3.5				
	300	3.5				
	400	3.5				
	500	3.5				
	600	3.5				

G2JHB2M

		Y-axis stroke				
		800	900	1000	1100	1200
Z-axis stroke	100	9.0				
	200	9.0				
	300	9.0				
	400	9.0				
	500	9.0				
	600	9.0				

G2JHB2L

		Y-axis stroke				
		800	900	1000	1100	1200
Z-axis stroke	100	19.0				
	200	19.0				
	300	19.0				
	400	19.0				
	500	18.8				
	600	17.8				

Maximum Speed by Stroke (mm/sec) (Note4)

G2JHB2H

	Stroke														
	100~600	800~900	1000~1200	1300~1400	1500	1600	1700	1800	1900	2000	2100	2200	2300	2400	2500
X-axis	-	-	1000		950	830	740	650	590	540	490	440	410	370	300
Y-axis	-	1000		-	-	-	-	-	-	-	-	-	-	-	-
Z-axis	1000	-	-	-	-	-	-	-	-	-	-	-	-	-	-

G2JHB2M

	Stroke														
	100~600	800~900	1000~1200	1300~1400	1500	1600	1700	1800	1900	2000	2100	2200	2300	2400	2500
X-axis	-	-	1000		950	830	740	650	590	540	490	440	410	370	300
Y-axis	-	1000		-	-	-	-	-	-	-	-	-	-	-	-
Z-axis	500	-	-	-	-	-	-	-	-	-	-	-	-	-	-

G2JHB2L

	Stroke														
	100~600	800~900	1000~1200	1300~1400	1500	1600	1700	1800	1900	2000	2100	2200	2300	2400	2500
X-axis	-	-	1000		950	830	740	650	590	540	490	440	410	370	300
Y-axis	-	1000		-	-	-	-	-	-	-	-	-	-	-	-
Z-axis	250	-	-	-	-	-	-	-	-	-	-	-	-	-	-

Dimensions

\* The configuration position in the figure is home position. To change the home position, indicate NM in the option. Note that changing the home direction will require the actuator to be returned to IAI for adjustment.

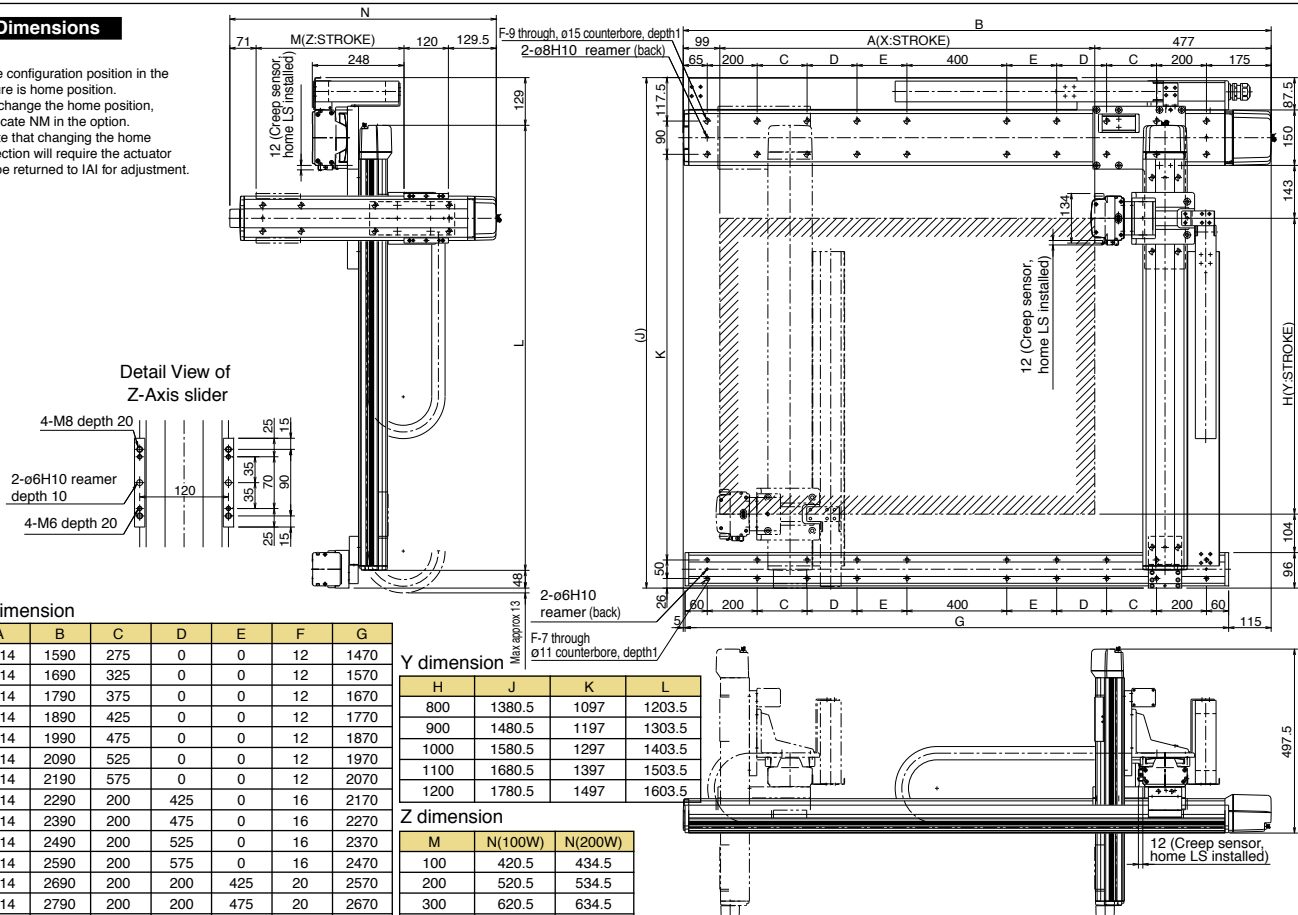

X dimension

A	B	C	D	E	F	G
1014	1590	275	0	0	12	1470
1114	1690	325	0	0	12	1570
1214	1790	375	0	0	12	1670
1314	1890	425	0	0	12	1770
1414	1990	475	0	0	12	1870
1514	2090	525	0	0	12	1970
1614	2190	575	0	0	12	2070
1714	2290	200	425	0	16	2170
1814	2390	200	475	0	16	2270
1914	2490	200	525	0	16	2370
2014	2590	200	575	0	16	2470
2114	2690	200	200	425	20	2570
2214	2790	200	200	475	20	2670
2314	2890	200	200	525	20	2770
2414	2990	200	200	575	20	2870
2514	3090	200	200	625	20	2970

Y dimension

H	J	K	L
800	1380.5	1097	1203.5
900	1480.5	1197	1303.5
1000	1580.5	1297	1403.5
1100	1680.5	1397	1503.5
1200	1780.5	1497	1603.5

Z dimension

M	N(100W)	N(200W)
100	420.5	434.5
200	520.5	534.5
300	620.5	634.5
400	720.5	734.5
500	820.5	834.5
600	920.5	934.5

<b>ICSA3-G2JHB3</b>		Cartesian Robot: X-Y-Z 3-Axes Configuration Z-Axis Base Mount Type	
<b>ICSPA3-G2JHB3</b>		Cartesian Robot: X-Y-Z 3-Axes Configuration Z-Axis Base Mount Type <b>High-Precision Specification</b>	
Type	XYG + Z-Axis Base Mount Type	Stroke	X-axis: 1000-2500mm Y-axis: 800-1200mm Z-axis: 100-600mm
		Load capacity	19kg ~ 9kg
Model specification items	Series	Type	Encoder type
(Example)	ICSA3 (ICSPA3)	G2JHB3H	A
			100AQL
			80AQL
			30BL
			T1
			5L
			CT-SC

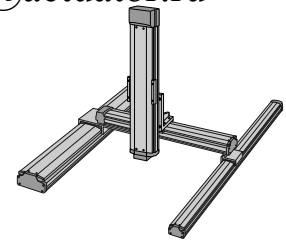

\* Refer to page 51 for the details of model specification items.

**Models/Specifications**

\* [ ] is for the high-precision specification.

Encoder Type	XY-axis configuration direction	Z-axis type (*1)	Model
Absolute	-	H	ICSA3 [ICSPA3] -G2JHB3H-A- <b>1</b> - <b>2</b> - <b>3</b> -B-T1- <b>4</b> - <b>5</b>
		M	ICSA3 [ICSPA3] -G2JHB3M-A- <b>1</b> - <b>2</b> - <b>3</b> -B-T1- <b>4</b> - <b>5</b>
		L	ICSA3 [ICSPA3] -G2JHB3L-A- <b>1</b> - <b>2</b> - <b>3</b> -B-T1- <b>4</b> - <b>5</b>
Incremental	-	H	ICSA3 [ICSPA3] -G2JHB3H-I- <b>1</b> - <b>2</b> - <b>3</b> -B-T1- <b>4</b> - <b>5</b>
		M	ICSA3 [ICSPA3] -G2JHB3M-I- <b>1</b> - <b>2</b> - <b>3</b> -B-T1- <b>4</b> - <b>5</b>
		L	ICSA3 [ICSPA3] -G2JHB3L-I- <b>1</b> - <b>2</b> - <b>3</b> -B-T1- <b>4</b> - <b>5</b>

\*1: The load capacity and the maximum speed may vary depending on the type of Z-axis.  
Note: T1 in the above models will be T2 when operated with XSEL-P/Q type.

**Explanation of Model Code**

Number	Contents	Specification
<b>1</b>	X-axis stroke (Note 1)	100 : 1000mm ~ 250 : 2500mm
<b>2</b>	Y-axis stroke (Note 1)	80 : 800mm ~ 120 : 1200mm
<b>3</b>	Z-axis stroke (Note 1)	10 : 100mm ~ 60 : 600mm
<b>4</b>	Cable length (Note 2)	3L : 3m 5L : 5m
<b>5</b>	Y-axis/ Z-axis cable management	CT-SC : Self-standing cable (*2) CT-CT : Cable track

\* The above explains the Models/Specifications chart to the left.  
\*2 Only cable track can be specified for the Y-axis cable management with model # G2JHB3D.

**Options**

Please add the option codes at the end of each stroke of the axis.  
When adding multiple options, put together in alphabetic order.

Name	Code	Page
AQ seal	AQ	→P13
Brake	B	→P13
Creep sensor	C	→P13
Home limit switch	L	→P14
Reversed-home specification	NM	→P14
Guide with ball-retaining mechanism	RT	→P14

**Common Specifications**

\* [ ] is for the high-precision specification.

Drive system	Ball screw, rolled C10 [equivalent to rolled C5]
Positioning repeatability	±0.02mm [±0.01mm]
Backlash	0.05mm or less [0.02mm or less]
Guide	Integrated with base
Base	Material: Aluminum with white alumite treatment
X-axis motor output / lead	400W / 20mm
Y-axis motor output / lead	200W / 20mm
Z-axis motor output / lead	200W / 20mm (H), 10mm (M)

**Applicable Controller Specifications**

Refer to page 65 for System Configuration.

**Axis Configuration**

\* [ ] is for the high-precision specification.

Axis Type	Model	Page
X-axis	ISA[ISPA]-LXUWX-□-400-20-(Stroke)-T1	→P30
Y-axis	ISA[ISPA]-MXMX-□-200-20-(Stroke)-T1	→P20
Z-axis	ISA[ISPA]-MXM-□-200-20/10-(Stroke)-T1-B	→P19

\*In the above model name, □ indicates encoder type A (absolute) or I (incremental).

**Caution**

(Note 1) The stroke in the model is specified in cm (centimeters).  
 (Note 2) The cable length measures from the X-axis connector box to the controller. The standard lengths are 3m and 5m, but other lengths can also be specified in meters. The maximum length is 20m.  
 (Note 3) The rated acceleration is 0.3G. Increasing the acceleration will result in lower load capacity.  
 (Note 4) Please note that a longer stroke will result in a lower maximum speed.

\* For other points to note, please refer to page 49.

ICSA3 [ICSPA3] -G2JHB3□

Load Capacity (kg) (Note3)

G2JHB3H

		Y-axis stroke				
		800	900	1000	1100	1200
Z-axis stroke	100	9.0				
	200	9.0				
	300	9.0				
	400	9.0				
	500	9.0				
	600	9.0				

G2JHB3M

		Y-axis stroke				
		800	900	1000	1100	1200
Z-axis stroke	100	19.0				
	200	19.0				
	300	19.0				
	400	18.7				
	500	17.6				
	600	16.6				

Maximum Speed by Stroke (mm/sec) (Note4)

G2JHB3H

	Stroke														
	100~600	800~900	1000~1200	1300~1400	1500	1600	1700	1800	1900	2000	2100	2200	2300	2400	2500
X-axis	-	-	1000		950	830	740	650	590	540	490	440	410	370	300
Y-axis	-	1000		-	-	-	-	-	-	-	-	-	-	-	-
Z-axis	1000	-	-	-	-	-	-	-	-	-	-	-	-	-	-

G2JHB3M

	Stroke														
	100~600	800~900	1000~1200	1300~1400	1500	1600	1700	1800	1900	2000	2100	2200	2300	2400	2500
X-axis	-	-	1000		950	830	740	650	590	540	490	440	410	370	300
Y-axis	-	1000		-	-	-	-	-	-	-	-	-	-	-	-
Z-axis	500	-	-	-	-	-	-	-	-	-	-	-	-	-	-

Dimensions

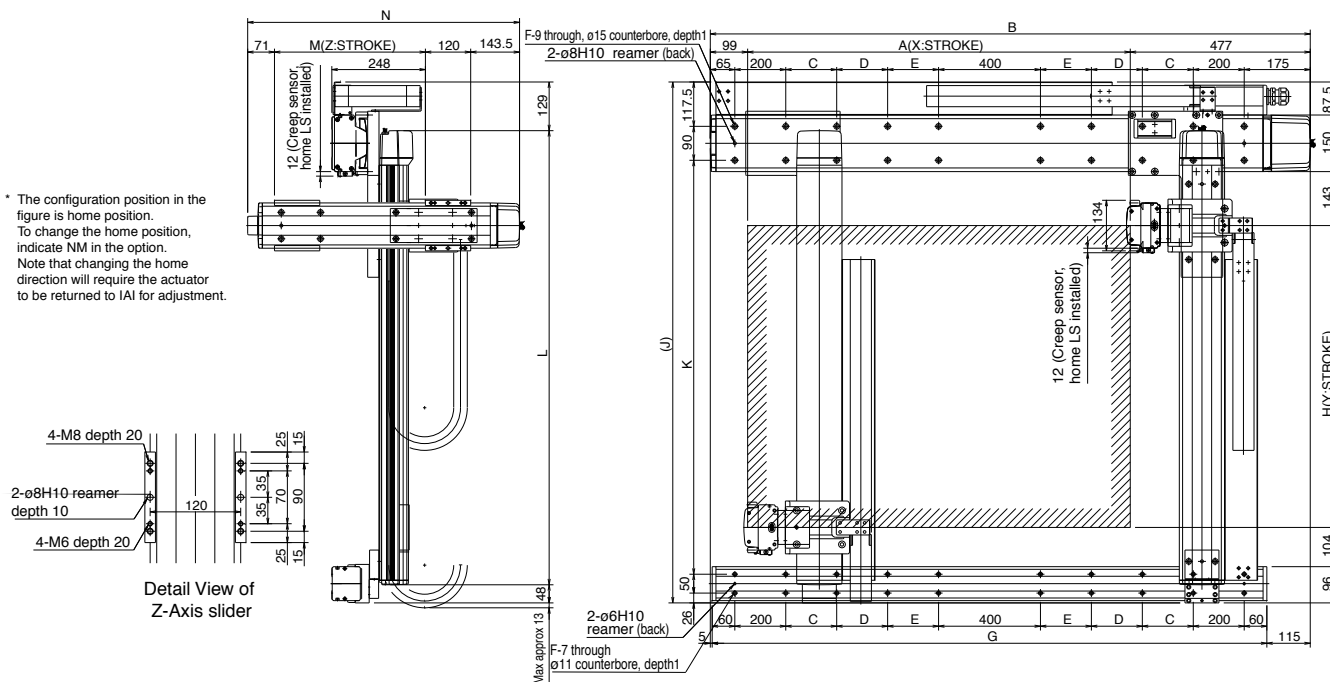

X dimension

A	B	C	D	E	F	G
1014	1590	275	0	0	12	1470
1114	1690	325	0	0	12	1570
1214	1790	375	0	0	12	1670
1314	1890	425	0	0	12	1770
1414	1990	475	0	0	12	1870
1514	2090	525	0	0	12	1970
1614	2190	575	0	0	12	2070
1714	2290	200	425	0	16	2170
1814	2390	200	475	0	16	2270
1914	2490	200	525	0	16	2370
2014	2590	200	575	0	16	2470
2114	2690	200	200	425	20	2570
2214	2790	200	200	475	20	2670
2314	2890	200	200	525	20	2770
2414	2990	200	200	575	20	2870
2514	3090	200	200	625	20	2970

Y dimension

H	J	K	L
800	1380.5	1097	1203.5
900	1480.5	1197	1303.5
1000	1580.5	1297	1403.5
1100	1680.5	1397	1503.5
1200	1780.5	1497	1603.5

Z dimension

M	N(100W)	N(200W)
100	420.5	434.5
200	520.5	534.5
300	620.5	634.5
400	720.5	734.5
500	820.5	834.5
600	920.5	934.5

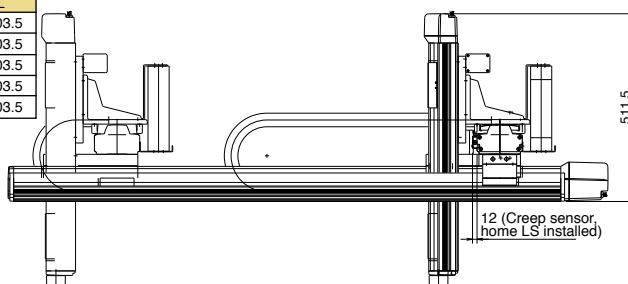

<b>ICSA3-G1JHS1</b> <input type="checkbox"/>		Cartesian Robot: X-Y-Z 3-Axes Configuration Z-Axis Slider Mount Type
<b>ICSPA3-G1JHS1</b> <input type="checkbox"/>		Cartesian Robot: X-Y-Z 3-Axes Configuration Z-Axis Slider Mount Type <b>High-Precision Specification</b>
Type	XYG + Z-Axis Slider Mount Type	Stroke X-axis: 1000-2500mm Y-axis: 500-700mm Z-axis: 100-400mm
		Load capacity 11kg - 0.9kg
Model specification items	Series	Type Encoder type X-axis stroke + options Y-axis stroke + options Z-axis stroke + options Applicable controller Cable length Cable management
(Example)	ICSA3 (ICSPA3) - G1JHS1H -	A - 100AQL - 50AQL - 30BLNM - T1 - 5L - CT - SC

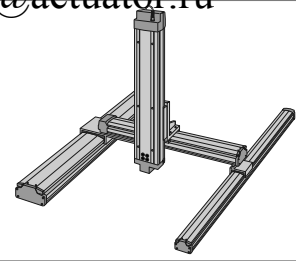

\* Refer to page 51 for the details of model specification items.

**Models/Specifications**

\* [ ] is for the high-precision specification.

Encoder Type	XY-axis configuration direction	Z-axis type (*1)	Model
Absolute	-	M	ICSA3 [ICSPA3] -G1JHS1M-A- <input type="checkbox"/> - <input type="checkbox"/> - <input type="checkbox"/> -BNM-T1- <input type="checkbox"/> - <input type="checkbox"/>
		L	ICSA3 [ICSPA3] -G1JHS1L-A- <input type="checkbox"/> - <input type="checkbox"/> - <input type="checkbox"/> -BNM-T1- <input type="checkbox"/> - <input type="checkbox"/>
Incremental	-	M	ICSA3 [ICSPA3] -G1JHS1M-I- <input type="checkbox"/> - <input type="checkbox"/> - <input type="checkbox"/> -BNM-T1- <input type="checkbox"/> - <input type="checkbox"/>
		L	ICSA3 [ICSPA3] -G1JHS1L-I- <input type="checkbox"/> - <input type="checkbox"/> - <input type="checkbox"/> -BNM-T1- <input type="checkbox"/> - <input type="checkbox"/>

\*1: The load capacity and the maximum speed may vary depending on the type of Z-axis.  
Note: T1 in the above models will be T2 when operated with XSEL-P/Q type.

**Explanation of Model Code**

Number	Contents	Specification
<input type="checkbox"/>	X-axis stroke (Note 1)	100 : 1000mm ~ 250 : 2500mm
<input type="checkbox"/>	Y-axis stroke (Note 1)	50 : 500mm ~ 70 : 700mm
<input type="checkbox"/>	Z-axis stroke (Note 1)	10 : 100mm ~ 40 : 400mm
<input type="checkbox"/>	Cable length (Note 2)	3L : 3m 5L : 5m
<input type="checkbox"/>	Y-axis/ Z-axis cable management	CT-SC : Self-standing cable (*2)

\* The above explains the Models/Specifications chart to the left.  
\*2 Only cable track can be specified for the Y-axis cable management with model # G1JHS1□ .

**Options**

Please add the option codes at the end of each stroke of the axis.  
When adding multiple options, put together in alphabetic order.

Name	Code	Page
AQ seal	AQ	→P13
Brake	B	→P13
Creep sensor	C	→P13
Home limit switch	L	→P14
Reversed-home specification	NM	→P14
Guide with ball-retaining mechanism	RT	→P14

**Common Specifications**

\* [ ] is for the high-precision specification.

Drive system	Ball screw, rolled C10 [equivalent to rolled C5]
Positioning repeatability	±0.02mm [±0.01mm]
Backlash	0.05mm or less [0.02mm or less]
Guide	Integrated with base
Base	Material: Aluminum with white alumite treatment
X-axis motor output / lead	400W / 20mm
Y-axis motor output / lead	200W / 20mm
Z-axis motor output / lead	60W / 8mm (M), 4mm (L)

**Applicable Controller Specifications**

Refer to page 65 for System Configuration.

**Axis Configuration**

\* [ ] is for the high-precision specification.

Axis Type	Model	Page
X-axis	ISA[ISPA]-LXUWX-□-400-20-(Stroke)-T1	→P30
Y-axis	ISA[ISPA]-MXM-□-200-20-(Stroke)-T1	→P19
Z-axis	ISA[ISPA]-SZM-□-60-8/4-(Stroke)-T1-B-NM	→P17

\*In the above model name, □ indicates encoder type A (absolute) or I (incremental).

**Caution**

(Note 1) The stroke in the model is specified in cm (centimeters).  
 (Note 2) The cable length measures from the X-axis connector box to the controller. The standard lengths are 3m and 5m, but other lengths can also be specified in meters. The maximum length is 20m.  
 (Note 3) The rated acceleration is 0.3G. Increasing the acceleration will result in lower load capacity.  
 (Note 4) Please note that a longer stroke will result in a lower maximum speed.

\* For other points to note, please refer to page 49.



ICSA3 [ICSPA3] -G1JHS1□

Load Capacity (kg) (Note3)

G1JHS1M

		Y-axis stroke		
		500	600	700
Z-axis stroke	100	3.0		
	200	2.3		
	300	1.6		
	400	0.9		

G1JHS1L

		Y-axis stroke		
		500	600	700
Z-axis stroke	100	11.0		
	200	10.3		
	300	9.6		
	400	8.9		

Maximum Speed by Stroke (mm/sec) (Note4)

G1JHS1M

	Stroke															
	100~400	500	600	700	1000~1400	1500	1600	1700	1800	1900	2000	2100	2200	2300	2400	2500
X-axis	-	-	-	-	1000	950	830	740	650	590	540	490	440	410	370	300
Y-axis	-	1000			-	-	-	-	-	-	-	-	-	-	-	-
Z-axis	400	-	-	-	-	-	-	-	-	-	-	-	-	-	-	-

G1JHS1L

	Stroke															
	100~400	500	600	700	1000~1400	1500	1600	1700	1800	1900	2000	2100	2200	2300	2400	2500
X-axis	-	-	-	-	1000	950	830	740	650	590	540	490	440	410	370	300
Y-axis	-	1000			-	-	-	-	-	-	-	-	-	-	-	-
Z-axis	200	-	-	-	-	-	-	-	-	-	-	-	-	-	-	-

Dimensions

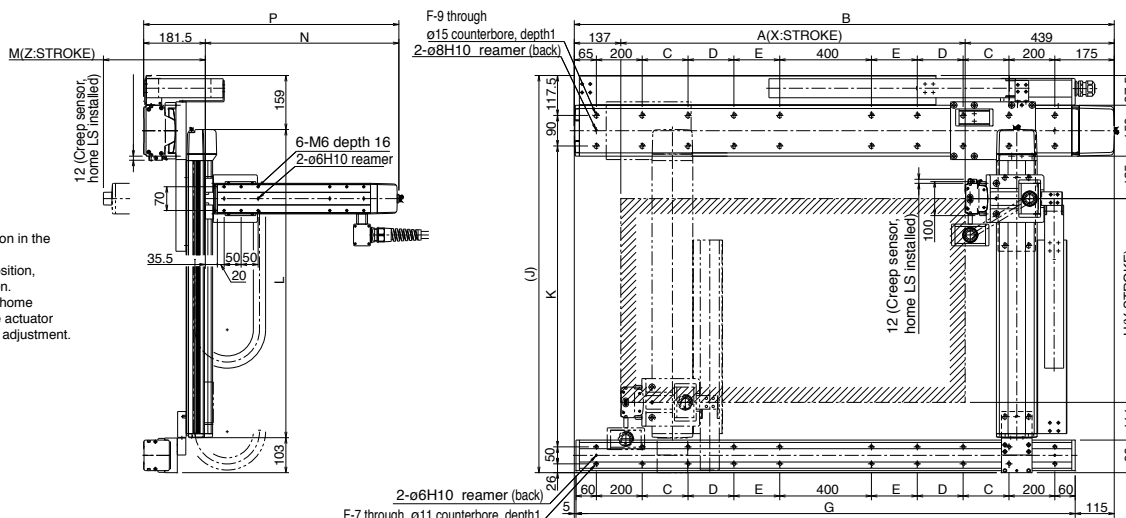

\* The configuration position in the figure is home position. To change the home position, indicate NM in the option. Note that changing the home direction will require the actuator to be returned to IAI for adjustment.

X dimension

	A	B	C	D	E	F	G
1014	1590	275	0	0	12	1470	
1114	1690	325	0	0	12	1570	
1214	1790	375	0	0	12	1670	
1314	1890	425	0	0	12	1770	
1414	1990	475	0	0	12	1870	
1514	2090	525	0	0	12	1970	
1614	2190	575	0	0	12	2070	
1714	2290	200	425	0	16	2170	
1814	2390	200	475	0	16	2270	
1914	2490	200	525	0	16	2370	
2014	2590	200	575	0	16	2470	
2114	2690	200	200	425	20	2570	
2214	2790	200	200	475	20	2670	
2314	2890	200	200	525	20	2770	
2414	2990	200	200	575	20	2870	
2514	3090	200	200	625	20	2970	

Y dimension

	H	J	K	L
500	1069.5	786	807.5	
600	1169.5	886	907.5	
700	1269.5	986	1007.5	

Z dimension

	M	N	P	Q
100	370	370	(800)	
200	470	470	(900)	
300	570	570	(1000)	
400	670	670	(1100)	

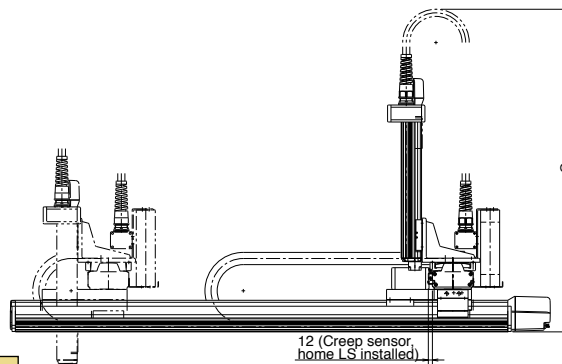

<b>ICSA3-G1JHS2L</b>		Cartesian Robot: X-Y-Z 3-Axes Configuration Z-Axis Slider Mount Type	
<b>ICSPA3-G1JHS2L</b>		Cartesian Robot: X-Y-Z 3-Axes Configuration Z-Axis Slider Mount Type <b>High-Precision Specification</b>	
Type	XYG + Z-Axis Slider Mount Type	Stroke	X-axis: 1000-2500mm Y-axis: 500-700mm Z-axis: 100-400mm
		Load capacity	13.1kg ~ 10.1kg
Model specification items	Series	Type	Encoder type
(Example)	ICSA3 (ICSPA3)	- G1JHS2L -	A
		- 100AQL -	50AQL -
		- 30BLNM -	T1 -
			5L - CT - SC

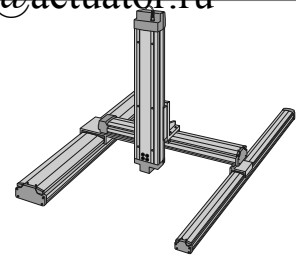

\* Refer to page 51 for the details of model specification items.

**Models/Specifications**

\* [ ] is for the high-precision specification.

Encoder Type	XY-axis configuration direction	Z-axis type (*1)	Model
Absolute	-	L	ICSA3 [ICSPA3] -G1JHS2L-A-[1]-[2]-[3]-BNM-T1-[4]-[5]
Incremental	-	L	ICSA3 [ICSPA3] -G1JHS2L-A-[1]-[2]-[3]-BNM-T1-[4]-[5]

\*1: The load capacity and the maximum speed may vary depending on the type of Z-axis.  
Note: T1 in the above models will be T2 when operated with XSEL-P/Q type.

**Explanation of Model Code**

Number	Contents	Specification
①	X-axis stroke (Note 1)	100 : 1000mm ~ 250 : 2500mm
②	Y-axis stroke (Note 1)	50 : 500mm ~ 70 : 700mm
③	Z-axis stroke (Note 1)	10 : 100mm ~ 40 : 400mm
④	Cable length (Note 2)	3L : 3m 5L : 5m
⑤	Y-axis/ Z-axis cable management	CT-SC : Self-standing cable (*2)

\* The above explains the Models/Specifications chart to the left.  
\*2 Only cable track can be specified for the Y-axis cable management with model # G1JHB2L.

**Options**

Please add the option codes at the end of each stroke of the axis.  
When adding multiple options, put together in alphabetic order.

Name	Code	Page
AQ seal	AQ	→P13
Brake	B	→P13
Creep sensor	C	→P13
Home limit switch	L	→P14
Reversed-home specification	NM	→P14
Guide with ball-retaining mechanism	RT	→P14

**Common Specifications**

\* [ ] is for the high-precision specification.

Drive system	Ball screw, rolled C10 [equivalent to rolled C5]
Positioning repeatability	±0.02mm [±0.01mm]
Backlash	0.05mm or less [0.02mm or less]
Guide	Integrated with base
Base	Material: Aluminum with white alumite treatment
X-axis motor output / lead	400W / 20mm
Y-axis motor output / lead	200W / 20mm
Z-axis motor output / lead	100W / 5mm

**Applicable Controller Specifications**

Refer to page 65 for System Configuration.

**Axis Configuration**

\* [ ] is for the high-precision specification.

Axis Type	Model	Page
X-axis	ISA[ISPA]-LXUWX-□-400-20-(Stroke)-T1	→P30
Y-axis	ISA[ISPA]-MXM-□-200-20-(Stroke)-T1	→P19
Z-axis	ISA[ISPA]-MXM-□-100-5-(Stroke)-T1-B-NM	→P18

\*In the above model name, □ indicates encoder type A (absolute) or I (incremental).

**Caution**

(Note 1) The stroke in the model is specified in cm (centimeters).  
 (Note 2) The cable length measures from the X-axis connector box to the controller. The standard lengths are 3m and 5m, but other lengths can also be specified in meters. The maximum length is 20m.  
 (Note 3) The rated acceleration is 0.3G. Increasing the acceleration will result in lower load capacity.  
 (Note 4) Please note that a longer stroke will result in a lower maximum speed.

\* For other points to note, please refer to page 49.

**ICSA3 [ICSPA3] -G1JHS2L**

**Load Capacity (kg) (Note3)**

**G1JHS2L**

		Y-axis stroke		
		500	600	700
Z-axis stroke	100	13.1		
	200	12.1		
	300	11.1		
	400	10.1		

**Maximum Speed by Stroke (mm/sec) (Note4)**

**G1JHS2L**

	Stroke													
	100~400	500~700	1000~1400	1500	1600	1700	1800	1900	2000	2100	2200	2300	2400	2500
X-axis	-		1000	950	830	740	650	590	540	490	440	410	370	300
Y-axis	-	1000	-	-	-	-	-	-	-	-	-	-	-	-
Z-axis	250	-	-	-	-	-	-	-	-	-	-	-	-	-

**Dimensions**

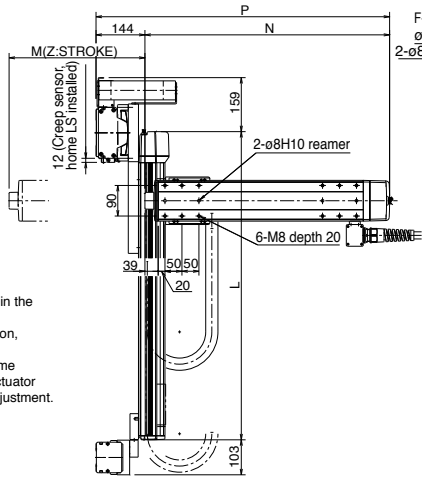

\* The configuration position in the figure is home position. To change the home position, indicate NM in the option. Note that changing the home direction will require the actuator to be returned to IAI for adjustment.

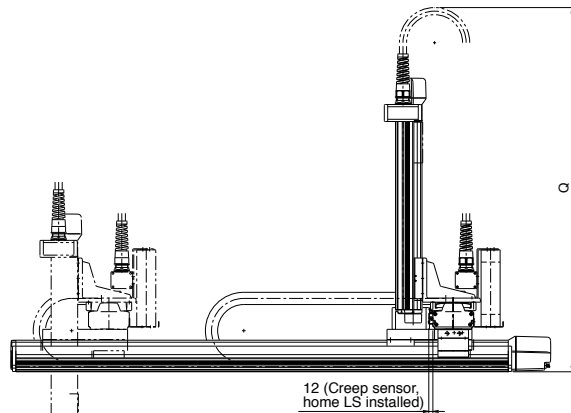
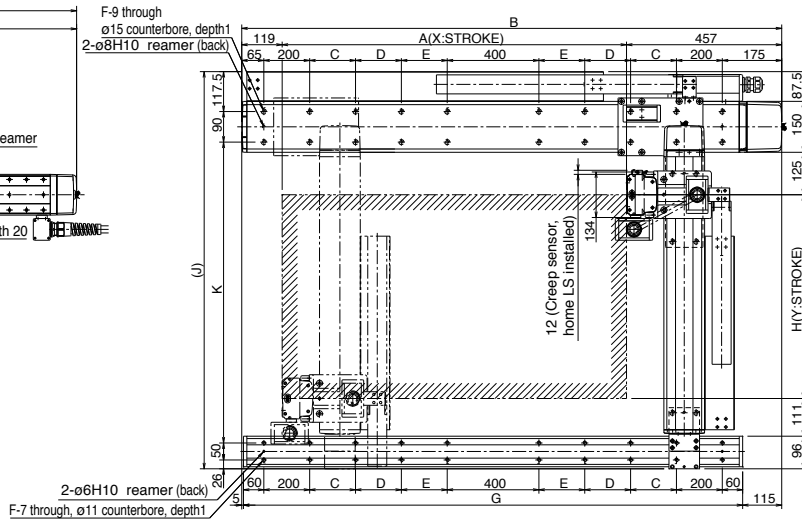

**X dimension**

A	B	C	D	E	F	G
1014	1590	275	0	0	12	1470
1114	1690	325	0	0	12	1570
1214	1790	375	0	0	12	1670
1314	1890	425	0	0	12	1770
1414	1990	475	0	0	12	1870
1514	2090	525	0	0	12	1970
1614	2190	575	0	0	12	2070
1714	2290	200	425	0	16	2170
1814	2390	200	475	0	16	2270
1914	2490	200	525	0	16	2370
2014	2590	200	575	0	16	2470
2114	2690	200	200	425	20	2570
2214	2790	200	200	475	20	2670
2314	2890	200	200	525	20	2770
2414	2990	200	200	575	20	2870
2514	3090	200	200	625	20	2970

**Y dimension**

H	J	K	L
500	1069.5	786	807.5
600	1169.5	886	907.5
700	1269.5	986	1007.5

**Z dimension**

M	N(100W)	N(200W)	P(100W)	P(200W)	Q
100	420.5	434.5	564.5	578.5	(800)
200	520.5	534.5	664.5	678.5	(900)
300	620.5	634.5	764.5	778.5	(1000)
400	720.5	734.5	864.5	878.5	(1100)
500	820.5	834.5	964.5	978.5	(1200)

<b>ICSA3-G1JHS3M</b>		Cartesian Robot: X-Y-Z 3-Axes Configuration Z-Axis Slider Mount Type	
<b>ICSPA3-G1JHS3M</b>		Cartesian Robot: X-Y-Z 3-Axes Configuration Z-Axis Slider Mount Type <b>High-Precision Specification</b>	
Type	XYG + Z-Axis Slider Mount Type	Stroke	X-axis: 1000-2500mm Y-axis: 500-700mm Z-axis: 100-500mm
		Load capacity	11.9kg - 7.8kg
Model specification items	Series	Type	Encoder type
(Example)	ICSA3 (ICSPA3)	- G1JHS3M -	A
			- 100AQL - 50AQL - 30BLNM - T1 - 5L - CT - SC

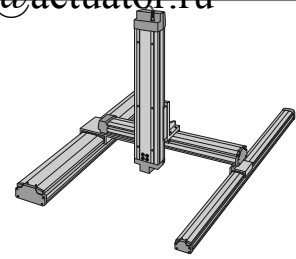

\* Refer to page 51 for the details of model specification items.

**Models/Specifications**

\* [ ] is for the high-precision specification.

Encoder Type	XY-axis configuration direction	Z-axis type (*1)	Model
Absolute	-	M	ICSA3 [ICSPA3] -G1JHS3M-A-①-②-③-BNM-T1-④-⑤
Incremental	-	M	ICSA3 [ICSPA3] -G1JHS3M-A-①-②-③-BNM-T1-④-⑤

\*1: The load capacity and the maximum speed may vary depending on the type of Z-axis.  
Note: T1 in the above models will be T2 when operated with XSEL-P/Q type.

**Explanation of Model Code**

Number	Contents	Specification
①	X-axis stroke (Note 1)	100 : 1000mm ~ 250 : 2500mm
②	Y-axis stroke (Note 1)	50 : 500mm ~ 70 : 700mm
③	Z-axis stroke (Note 1)	10 : 100mm ~ 50 : 500mm
④	Cable length (Note 2)	3L : 3m 5L : 5m
⑤	Y-axis/ Z-axis cable management	CT-SC : Self-standing cable (*2)

\* The above explains the Models/Specifications chart to the left.  
\*2 Only cable track can be specified for the Y-axis cable management with model # G1JHS3M.

**Options**

Please add the option codes at the end of each stroke of the axis.  
When adding multiple options, put together in alphabetic order.

Name	Code	Page
AQ seal	AQ	→P13
Brake	B	→P13
Creep sensor	C	→P13
Home limit switch	L	→P14
Reversed-home specification	NM	→P14
Guide with ball-retaining mechanism	RT	→P14

**Common Specifications**

\* [ ] is for the high-precision specification.

Drive system	Ball screw, rolled C10 [equivalent to rolled C5]
Positioning repeatability	±0.02mm [±0.01mm]
Backlash	0.05mm or less [0.02mm or less]
Guide	Integrated with base
Base	Material: Aluminum with white alumite treatment
X-axis motor output / lead	400W / 20mm
Y-axis motor output / lead	200W / 20mm
Z-axis motor output / lead	200W / 10mm

**Applicable Controller Specifications**

Refer to page 65 for System Configuration.

**Axis Configuration**

\* [ ] is for the high-precision specification.

Axis Type	Model	Page
X-axis	ISA[ISPA]-LXUWX-□-400-20-(Stroke)-T1	→P30
Y-axis	ISA[ISPA]-MXM-□-200-20-(Stroke)-T1	→P19
Z-axis	ISA[ISPA]-MZM-□-200-10-(Stroke)-T1-B-NM	→P24

\*In the above model name, □ indicates encoder type A (absolute) or I (incremental).

**Caution**

(Note 1) The stroke in the model is specified in cm (centimeters).  
 (Note 2) The cable length measures from the X-axis connector box to the controller. The standard lengths are 3m and 5m, but other lengths can also be specified in meters. The maximum length is 20m.  
 (Note 3) The rated acceleration is 0.3G. Increasing the acceleration will result in lower load capacity.  
 (Note 4) Please note that a longer stroke will result in a lower maximum speed.

\* For other points to note, please refer to page 49.

**ICSA3 [ICSPA3] -G1JHS3M**

**Load Capacity (kg) (Note3)**

**G1JHS3M**

		Y-axis stroke		
		500	600	700
Z-axis stroke	100	11.9		
	200	10.9		
	300	9.9		
	400	8.9		
	500	7.8		

**Maximum Speed by Stroke (mm/sec) (Note4)**

**G1JHS3M**

	Stroke															
	100~400	500	600	700	1000~1400	1500	1600	1700	1800	1900	2000	2100	2200	2300	2400	2500
X-axis	-	-	-	-	1000	950	830	740	650	590	540	490	440	410	370	300
Y-axis	-				1000	-	-	-	-	-	-	-	-	-	-	-
Z-axis	500			-	-	-	-	-	-	-	-	-	-	-	-	-

**Dimensions**

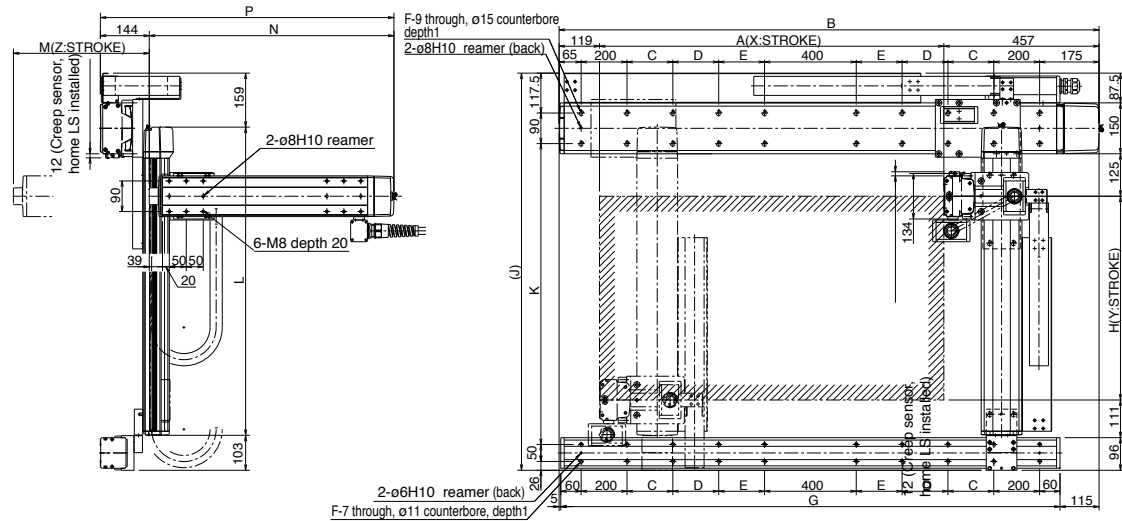

\* The configuration position in the figure is home position. To change the home position, indicate NM in the option. Note that changing the home direction will require the actuator to be returned to IAI for adjustment.

**X dimension**

A	B	C	D	E	F	G
1014	1590	275	0	0	12	1470
1114	1690	325	0	0	12	1570
1214	1790	375	0	0	12	1670
1314	1890	425	0	0	12	1770
1414	1990	475	0	0	12	1870
1514	2090	525	0	0	12	1970
1614	2190	575	0	0	12	2070
1714	2290	200	425	0	16	2170
1814	2390	200	475	0	16	2270
1914	2490	200	525	0	16	2370
2014	2590	200	575	0	16	2470
2114	2690	200	200	425	20	2570
2214	2790	200	200	475	20	2670
2314	2890	200	200	525	20	2770
2414	2990	200	200	575	20	2870
2514	3090	200	200	625	20	2970

**Y dimension**

H	J	K	L
500	1069.5	786	807.5
600	1169.5	886	907.5
700	1269.5	986	1007.5

**Z dimension**

M	N(100W)	N(200W)	P(100W)	P(200W)	Q
100	420.5	434.5	564.5	578.5	(800)
200	520.5	534.5	664.5	678.5	(900)
300	620.5	634.5	764.5	778.5	(1000)
400	720.5	734.5	864.5	878.5	(1100)
500	820.5	834.5	964.5	978.5	(1200)

<b>ICSA3-G2JHS1</b> □		Cartesian Robot: X-Y-Z 3-Axes Configuration Z-Axis Slider Mount Type	
<b>ICSPA3-G2JHS1</b> □		Cartesian Robot: X-Y-Z 3-Axes Configuration Z-Axis Slider Mount Type <b>High-Precision Specification</b>	
Type	XYG + Z-Axis Slider Mount Type	Stroke	X-axis: 1000-2500mm Y-axis: 800-1200mm Z-axis: 100-400mm
		Load capacity	11kg ~ 0.9kg
Model specification items	Series	Type	Encoder type
(Example)	ICSA3 (ICSPA3)	G2JHS1H	A
			100AQL
			100AQL
			30BLNM
			T1
			5L
			CT-SC

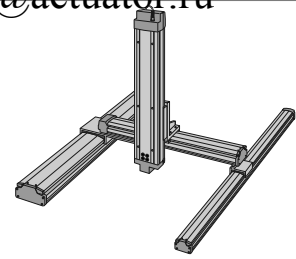

\* Refer to page 51 for the details of model specification items.

**Models/Specifications**

\* [ ] is for the high-precision specification.

Encoder Type	XY-axis configuration direction	Z-axis type (*1)	Model
Absolute	-	M	ICSA3 [ICSPA3] -G2JHS1M-A- [1] - [2] - [3] -BNM-T1- [4] - [5]
		L	ICSA3 [ICSPA3] -G2JHS1L-A- [1] - [2] - [3] -BNM-T1- [4] - [5]
Incremental	-	M	ICSA3 [ICSPA3] -G2JHS1M-I- [1] - [2] - [3] -BNM-T1- [4] - [5]
		L	ICSA3 [ICSPA3] -G2JHS1L-I- [1] - [2] - [3] -BNM-T1- [4] - [5]

\*1: The load capacity and the maximum speed may vary depending on the type of Z-axis.  
Note: T1 in the above models will be T2 when operated with XSEL-P/Q type.

**Explanation of Model Code**

Number	Contents	Specification
[1]	X-axis stroke (Note 1)	100 : 1000mm ~ 250 : 2500mm
[2]	Y-axis stroke (Note 1)	80 : 800mm ~ 120 : 1200mm
[3]	Z-axis stroke (Note 1)	10 : 100mm ~ 40 : 400mm
[4]	Cable length (Note 2)	3L : 3m 5L : 5m
[5]	Y-axis/ Z-axis cable management	CT-SC : Self-standing cable (*2)

\* The above explains the Models/Specifications chart to the left.  
\*2 Only cable track can be specified for the Y-axis cable management with model # G2JHS1□.

**Options**

Please add the option codes at the end of each stroke of the axis.  
When adding multiple options, put together in alphabetic order.

Name	Code	Page
AQ seal	AQ	→P13
Brake	B	→P13
Creep sensor	C	→P13
Home limit switch	L	→P14
Reversed-home specification	NM	→P14
Guide with ball-retaining mechanism	RT	→P14

**Common Specifications**

\* [ ] is for the high-precision specification.

Drive system	Ball screw, rolled C10 [equivalent to rolled C5]
Positioning repeatability	±0.02mm [±0.01mm]
Backlash	0.05mm or less [0.02mm or less]
Guide	Integrated with base
Base	Material: Aluminum with white alumite treatment
X-axis motor output / lead	400W / 20mm
Y-axis motor output / lead	200W / 20mm
Z-axis motor output / lead	60W / 8mm (M), 4mm (L)

**Applicable Controller Specifications**

Refer to page 65 for System Configuration.

**Axis Configuration**

\* [ ] is for the high-precision specification.

Axis Type	Model	Page
X-axis	ISA[ISPA]-LXUWX-□-400-20-(Stroke)-T1	→P30
Y-axis	ISA[ISPA]-MXMX-□-200-20-(Stroke)-T1	→P20
Z-axis	ISA[ISPA]-SZM-□-60-8/4-(Stroke)-T1-B-NM	→P17

\*In the above model name, □ indicates encoder type A (absolute) or I (incremental).

**Caution**

(Note 1) The stroke in the model is specified in cm (centimeters).  
 (Note 2) The cable length measures from the X-axis connector box to the controller. The standard lengths are 3m and 5m, but other lengths can also be specified in meters. The maximum length is 20m.  
 (Note 3) The rated acceleration is 0.3G. Increasing the acceleration will result in lower load capacity.  
 (Note 4) Please note that a longer stroke will result in a lower maximum speed.

\* For other points to note, please refer to page 49.

ICSA3 [ICSPA3] -G2JHS1□

Single-Axis Robots

Cartesian Robots

Controllers

**Load Capacity (kg) (Note3)**

**G2JHS1M**

		Y-axis stroke				
		800	900	1000	1100	1200
Z-axis stroke	100	3.0				
	200	2.3				
	300	1.6				
	400	0.9				

**G2JHS1L**

		Y-axis stroke				
		800	900	1000	1100	1200
Z-axis stroke	100	11.0				
	200	10.3				
	300	9.6				
	400	8.9				

**Maximum Speed by Stroke (mm/sec) (Note4)**

**G2JHS1M**

	Stroke														
	100~400	800~900	1000~1200	1300~1400	1500	1600	1700	1800	1900	2000	2100	2200	2300	2400	2500
X-axis	-	-	1000	-	950	830	740	650	590	540	490	440	410	370	300
Y-axis	-	1000	-	-	-	-	-	-	-	-	-	-	-	-	-
Z-axis	400	-	-	-	-	-	-	-	-	-	-	-	-	-	-

**G2JHS1L**

	Stroke														
	100~400	800~900	1000~1200	1300~1400	1500	1600	1700	1800	1900	2000	2100	2200	2300	2400	2500
X-axis	-	-	1000	-	950	830	740	650	590	540	490	440	410	370	300
Y-axis	-	1000	-	-	-	-	-	-	-	-	-	-	-	-	-
Z-axis	200	-	-	-	-	-	-	-	-	-	-	-	-	-	-

**Dimensions**

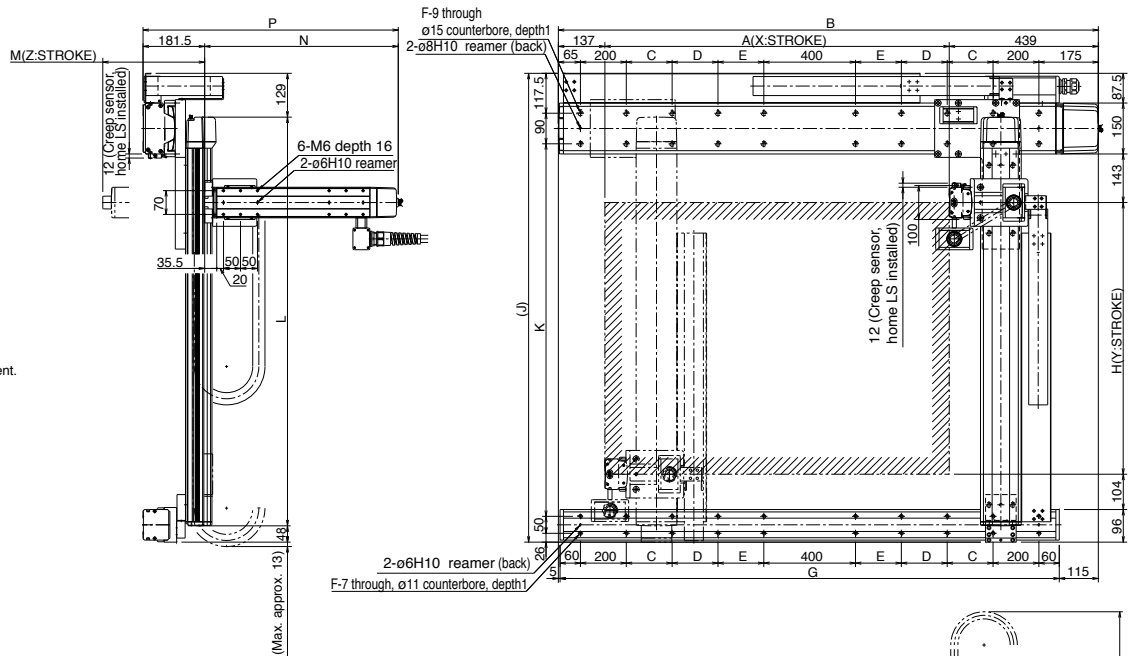

\* The configuration position in the figure is home position. To change the home position, indicate NM in the option. Note that changing the home direction will require the actuator to be returned to IAI for adjustment.

**X dimension**

A	B	C	D	E	F	G
1014	1590	275	0	0	12	1470
1114	1690	325	0	0	12	1570
1214	1790	375	0	0	12	1670
1314	1890	425	0	0	12	1770
1414	1990	475	0	0	12	1870
1514	2090	525	0	0	12	1970
1614	2190	575	0	0	12	2070
1714	2290	200	425	0	16	2170
1814	2390	200	475	0	16	2270
1914	2490	200	525	0	16	2370
2014	2590	200	575	0	16	2470
2114	2690	200	200	425	20	2570
2214	2790	200	200	475	20	2670
2314	2890	200	200	525	20	2770
2414	2990	200	200	575	20	2870
2514	3090	200	200	625	20	2970

**Y dimension**

H	J	K	L
800	1380.5	1097	1203.5
900	1480.5	1197	1303.5
1000	1580.5	1297	1403.5
1100	1680.5	1397	1503.5
1200	1780.5	1497	1603.5

**Z dimension**

M	N	P	Q
100	370	370	(800)
200	470	470	(900)
300	570	570	(1000)
400	670	670	(1100)

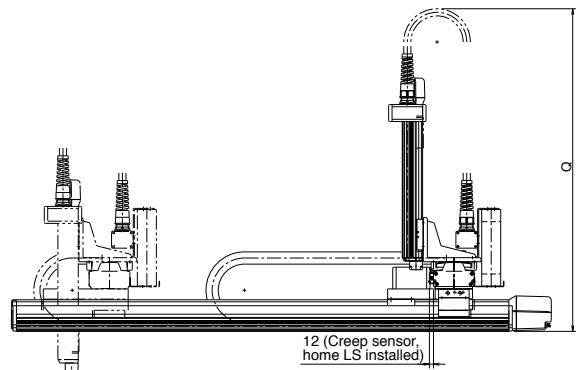

**ICSA3-G2JHS2L** Cartesian Robot: X-Y-Z 3-Axes Configuration  
Z-Axis Slider Mount Type

**ICSPA3-G2JHS2L** Cartesian Robot: X-Y-Z 3-Axes Configuration  
Z-Axis Slider Mount Type **High-Precision Specification**

Type XYG + Z-Axis Slider Mount Type Stroke X-axis: 1000-2500mm Y-axis: 800-1200mm Z-axis: 100-400mm Load capacity 13.1kg ~ 10.1kg

Model specification items Series Type Encoder type X-axis stroke + options Y-axis stroke + options Z-axis stroke + options Applicable controller Cable length Cable management  
(Example) ICSA3 (ICSPA3) - G2JHS2L - A - 100AQL - 100AQL - 30BLNM - T1 - 5L - CT - SC

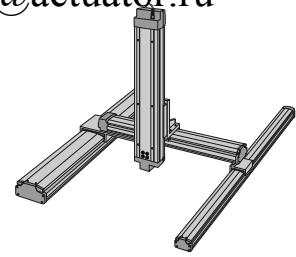

\* Refer to page 51 for the details of model specification items.

**Models/Specifications**

\* [ ] is for the high-precision specification.

Encoder Type	XY-axis configuration direction	Z-axis type (*1)	Model
Absolute	-	L	ICSA3 [ICSPA3] -G2JHS2L-A-[1]-[2]-[3]-BNM-T1-[4]-[5]
Incremental	-	L	ICSA3 [ICSPA3] -G2JHS2L-A-[1]-[2]-[3]-BNM-T1-[4]-[5]

\*1: The load capacity and the maximum speed may vary depending on the type of Z-axis.  
Note: T1 in the above models will be T2 when operated with XSEL-P/O type.

**Explanation of Model Code**

Number	Contents	Specification
①	X-axis stroke (Note 1)	100 : 1000mm ~ 250 : 2500mm
②	Y-axis stroke (Note 1)	80 : 800mm ~ 120 : 1200mm
③	Z-axis stroke (Note 1)	10 : 100mm ~ 40 : 400mm
④	Cable length (Note 2)	3L : 3m 5L : 5m
⑤	Y-axis/ Z-axis cable management	CT-SC : Self-standing cable (*2)

\* The above explains the Models/Specifications chart to the left.  
\*2 Only cable track can be specified for the Y-axis cable management with model # G2JHS2L.

**Options**

Please add the option codes at the end of each stroke of the axis.  
When adding multiple options, put together in alphabetic order.

Name	Code	Page
AQ seal	AQ	→P13
Brake	B	→P13
Creep sensor	C	→P13
Home limit switch	L	→P14
Reversed-home specification	NM	→P14
Guide with ball-retaining mechanism	RT	→P14

**Common Specifications**

\* [ ] is for the high-precision specification.

Drive system	Ball screw, rolled C10 [equivalent to rolled C5]
Positioning repeatability	±0.02mm [±0.01mm]
Backlash	0.05mm or less [0.02mm or less]
Guide	Integrated with base
Base	Material: Aluminum with white alumite treatment
X-axis motor output / lead	400W / 20mm
Y-axis motor output / lead	200W / 20mm
Z-axis motor output / lead	100W / 5mm (L)

**Applicable Controller Specifications**

Refer to page 65 for System Configuration.

**Axis Configuration**

\* [ ] is for the high-precision specification.

Axis Type	Model	Page
X-axis	ISA[ISPA]-LXUWX-□-400-20-(Stroke)-T1	→P30
Y-axis	ISA[ISPA]-MXMX-□-200-20-(Stroke)-T1	→P20
Z-axis	ISA[ISPA]-MZM-□-100-5-(Stroke)-T1-B-NM	→P23

\*In the above model name, □ indicates encoder type A (absolute) or I (incremental).

**Caution**

(Note 1) The stroke in the model is specified in cm (centimeters).  
(Note 2) The cable length measures from the X-axis connector box to the controller. The standard lengths are 3m and 5m, but other lengths can also be specified in meters. The maximum length is 20m.  
(Note 3) The rated acceleration is 0.3G. Increasing the acceleration will result in lower load capacity.  
(Note 4) Please note that a longer stroke will result in a lower maximum speed.

\* For other points to note, please refer to page 49.



**ICSA3 [ICSPA3] -G2JHS2L**

**Load Capacity by (kg) (Note3)**

**G2JHS2L**

		Y-axis stroke				
		800	900	1000	1100	1200
Z-axis stroke	100	13.1				
	200	12.1				
	300	11.1				
	400	10.1				

**Maximum Speed by Stroke (mm/sec) (Note4)**

**G2JHS2L**

	Stroke														
	100~400	800~900	1000~1200	1300~1400	1500	1600	1700	1800	1900	2000	2100	2200	2300	2400	2500
X-axis	-	-	1000		950	830	740	650	590	540	490	440	410	370	300
Y-axis	-	1000		-	-	-	-	-	-	-	-	-	-	-	-
Z-axis	250	-	-	-	-	-	-	-	-	-	-	-	-	-	-

**Dimensions**

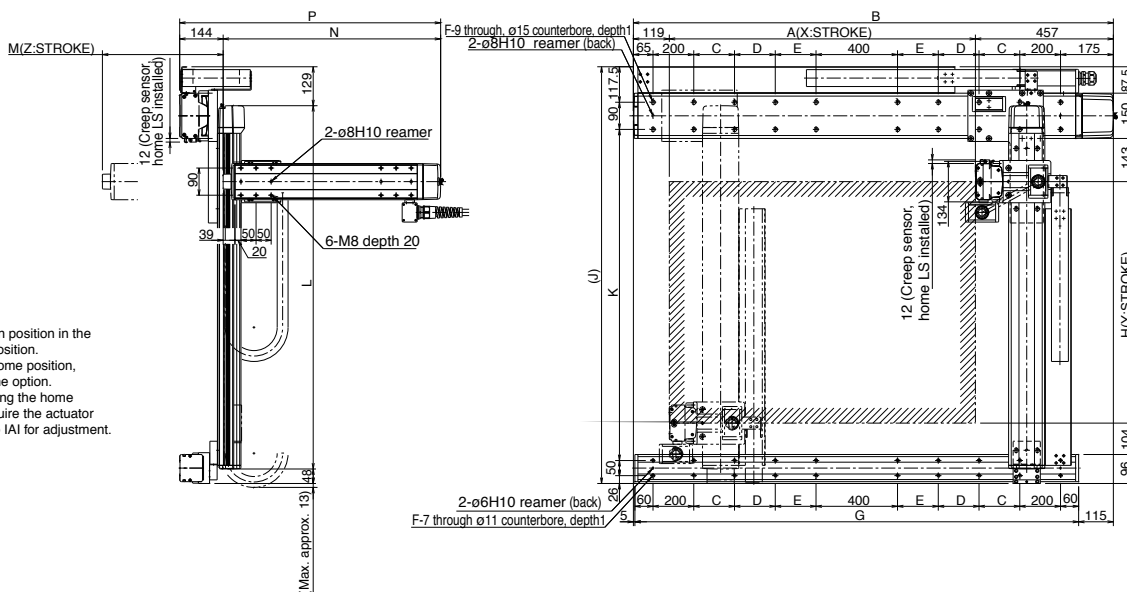

\* The configuration position in the figure is home position. To change the home position, indicate NM in the option. Note that changing the home direction will require the actuator to be returned to IAI for adjustment.

**X dimension**

A	B	C	D	E	F	G
1014	1590	275	0	0	12	1470
1114	1690	325	0	0	12	1570
1214	1790	375	0	0	12	1670
1314	1890	425	0	0	12	1770
1414	1990	475	0	0	12	1870
1514	2090	525	0	0	12	1970
1614	2190	575	0	0	12	2070
1714	2290	200	425	0	16	2170
1814	2390	200	475	0	16	2270
1914	2490	200	525	0	16	2370
2014	2590	200	575	0	16	2470
2114	2690	200	200	425	20	2570
2214	2790	200	200	475	20	2670
2314	2890	200	200	525	20	2770
2414	2990	200	200	575	20	2870
2514	3090	200	200	625	20	2970

**Y dimension**

H	J	K	L
800	1380.5	1097	1203.5
900	1480.5	1197	1303.5
1000	1580.5	1297	1403.5
1100	1680.5	1397	1503.5
1200	1780.5	1497	1603.5

**Z dimension**

M	N(100W)	N(200W)	P(100W)	P(200W)	Q
100	420.5	434.5	564.5	578.5	(800)
200	520.5	534.5	664.5	678.5	(900)
300	620.5	634.5	764.5	778.5	(1000)
400	720.5	734.5	864.5	878.5	(1100)
500	820.5	834.5	964.5	978.5	(1200)

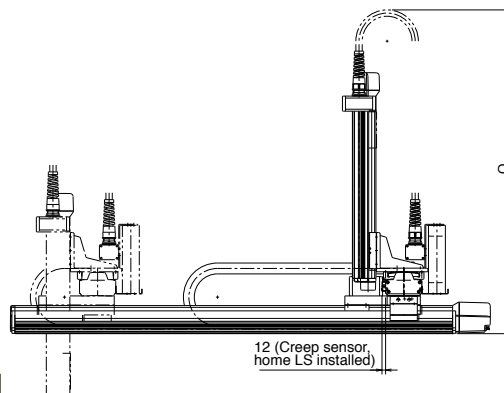

**ICSA3-G2JHS3M** Cartesian Robot: X-Y-Z 3-Axes Configuration  
Z-Axis Slider Mount Type

**ICSPA3-G2JHS3M** Cartesian Robot: X-Y-Z 3-Axes Configuration  
Z-Axis Slider Mount Type High-Precision Specification

Type: XYG + Z-Axis Slider Mount Type    Stroke: X-axis: 1000-2500mm Y-axis: 800-1200mm Z-axis: 100-500mm    Load capacity: 11.9kg ~ 7.8kg

Model specification items (Example): ICSA3 (ICSPA3) - G2JHS3M - A - 100AQL - 100AQL - 30BLNM - T1 - 5L - CT - SC

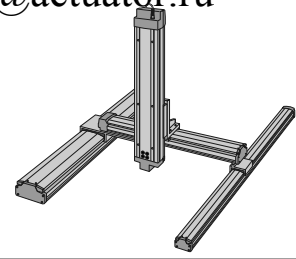

\* Refer to page 51 for the details of model specification items.

**Models/Specifications**

\* [ ] is for the high-precision specification.

Encoder Type	XY-axis configuration direction	Z-axis type (*1)	Model
Absolute	-	M	ICSA3 [ICSPA3] -G2JHS3M-A-①-②-③-BNM-T1-④-⑤
Incremental	-	M	ICSA3 [ICSPA3] -G2JHS3M-A-①-②-③-BNM-T1-④-⑤

\*1: The load capacity and the maximum speed may vary depending on the type of Z-axis.  
Note: T1 in the above models will be T2 when operated with XSEL-P/Q type.

**Explanation of Model Code**

Number	Contents	Specification
①	X-axis stroke (Note 1)	100 : 1000mm ~ 250 : 2500mm
②	Y-axis stroke (Note 1)	80 : 800mm ~ 120 : 1200mm
③	Z-axis stroke (Note 1)	10 : 100mm ~ 40 : 400mm
④	Cable length (Note 2)	3L : 3m 5L : 5m
⑤	Y-axis/ Z-axis cable management	CT-SC : Self-standing cable (*2)

\* The above explains the Models/Specifications chart to the left.  
\*2 Only cable track can be specified for the Y-axis cable management with model # G2JHS3M.

**Options**

Please add the option codes at the end of each stroke of the axis.  
When adding multiple options, put together in alphabetic order.

Name	Code	Page
AQ seal	AQ	→P13
Brake	B	→P13
Creep sensor	C	→P13
Home limit switch	L	→P14
Reversed-home specification	NM	→P14
Guide with ball-retaining mechanism	RT	→P14

**Common Specifications**

\* [ ] is for the high-precision specification.

Drive system	Ball screw, rolled C10 [equivalent to rolled C5]
Positioning repeatability	±0.02mm [±0.01mm]
Backlash	0.05mm or less [0.02mm or less]
Guide	Integrated with base
Base	Material: Aluminum with white alumite treatment
X-axis motor output / lead	400W / 20mm
Y-axis motor output / lead	200W / 20mm
Z-axis motor output / lead	200W / 10mm

**Applicable Controller Specifications**

Refer to page 65 for System Configuration.

**Axis Configuration**

\* [ ] is for the high-precision specification.

Axis Type	Model	Page
X-axis	ISA[ISPA]-LXUWX-□-400-20-(Stroke)-T1	→P30
Y-axis	ISA[ISPA]-MXMX-□-200-20-(Stroke)-T1	→P20
Z-axis	ISA[ISPA]-MZM-□-200-10-(Stroke)-T1-B-NM	→P24

\*In the above model name, □ indicates encoder type A (absolute) or I (incremental).

**Caution**

(Note 1) The stroke in the model is specified in cm (centimeters).  
 (Note 2) The cable length measures from the X-axis connector box to the controller. The standard lengths are 3m and 5m, but other lengths can also be specified in meters. The maximum length is 20m.  
 (Note 3) The rated acceleration is 0.3G. Increasing the acceleration will result in lower load capacity.  
 (Note 4) Please note that a longer stroke will result in a lower maximum speed.

\* For other points to note, please refer to page 49.

# ICSA3 [ICSPA3] -G2JHS3M

## Load Capacity (kg) (Note3)

### G2JHS3M

Z-axis stroke	Y-axis stroke				
	800	900	1000	1100	1200
100	11.9				
200	10.9				
300	9.9				
400	8.9				
500	7.8				

## Maximum Speed by Stroke (mm/sec) (Note4)

### G2JHS3M

	Stroke														
	100~400	800~900	1000~1200	1300~1400	1500	1600	1700	1800	1900	2000	2100	2200	2300	2400	2500
X-axis	-	-	1000	-	950	830	740	650	590	540	490	440	410	370	300
Y-axis	-	1000	-	-	-	-	-	-	-	-	-	-	-	-	-
Z-axis	500	-	-	-	-	-	-	-	-	-	-	-	-	-	-

## Dimensions

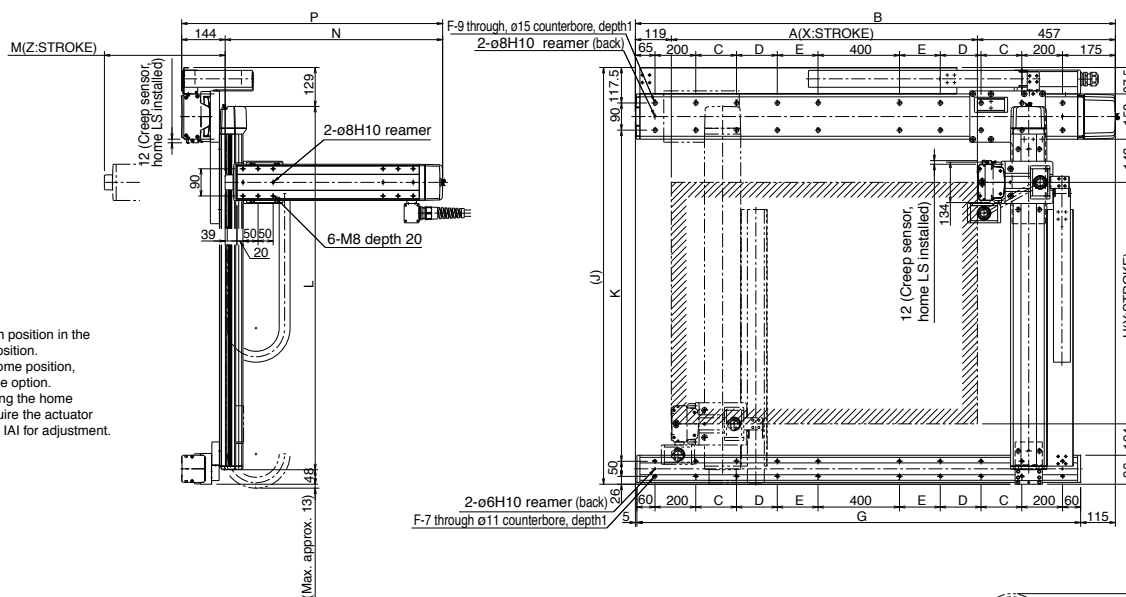

\* The configuration position in the figure is home position.  
To change the home position, indicate NM in the option.  
Note that changing the home direction will require the actuator to be returned to IAI for adjustment.

### X dimension

A	B	C	D	E	F	G
1014	1590	275	0	0	12	1470
1114	1690	325	0	0	12	1570
1214	1790	375	0	0	12	1670
1314	1890	425	0	0	12	1770
1414	1990	475	0	0	12	1870
1514	2090	525	0	0	12	1970
1614	2190	575	0	0	12	2070
1714	2290	200	425	0	16	2170
1814	2390	200	475	0	16	2270
1914	2490	200	525	0	16	2370
2014	2590	200	575	0	16	2470
2114	2690	200	200	425	20	2570
2214	2790	200	200	475	20	2670
2314	2890	200	200	525	20	2770
2414	2990	200	200	575	20	2870
2514	3090	200	200	625	20	2970

### Y dimension

H	J	K	L
800	1380.5	1097	1203.5
900	1480.5	1197	1303.5
1000	1580.5	1297	1403.5
1100	1680.5	1397	1503.5
1200	1780.5	1497	1603.5

### Z dimension

M	N(100W)	N(200W)	P(100W)	P(200W)	Q
100	420.5	434.5	564.5	578.5	(800)
200	520.5	534.5	664.5	678.5	(900)
300	620.5	634.5	764.5	778.5	(1000)
400	720.5	734.5	864.5	878.5	(1100)
500	820.5	834.5	964.5	978.5	(1200)

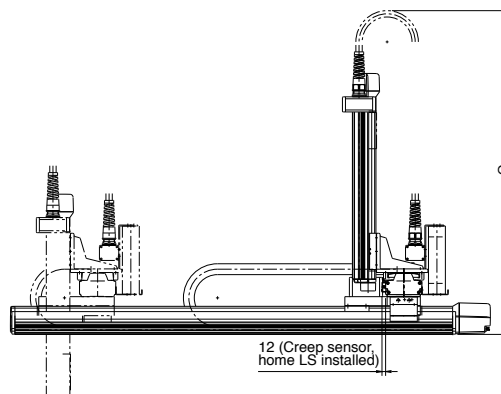

## ■ Cable Variations

The XYB type lets you select the self-standing cable (code: SC) or cable track (code: CT) variation.

Select an appropriate option depending on your specific need.

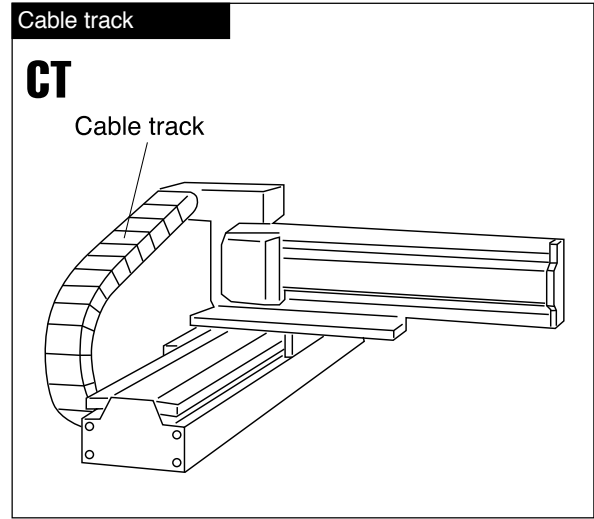
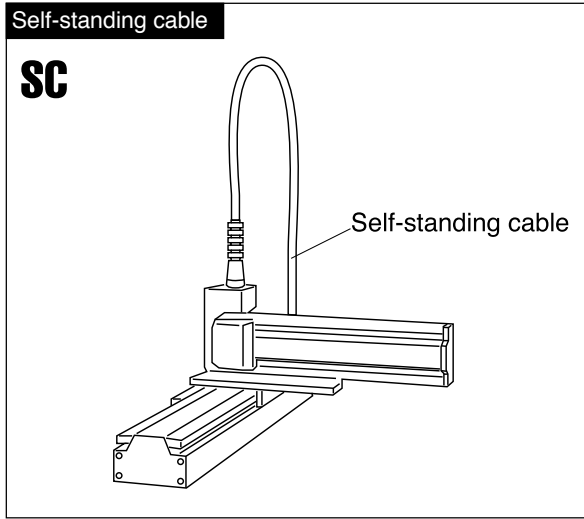

## ● Detail Drawing of Cable Track

Standard TKP0450-38B (Manufacturer: Tsubakimoto Chain)

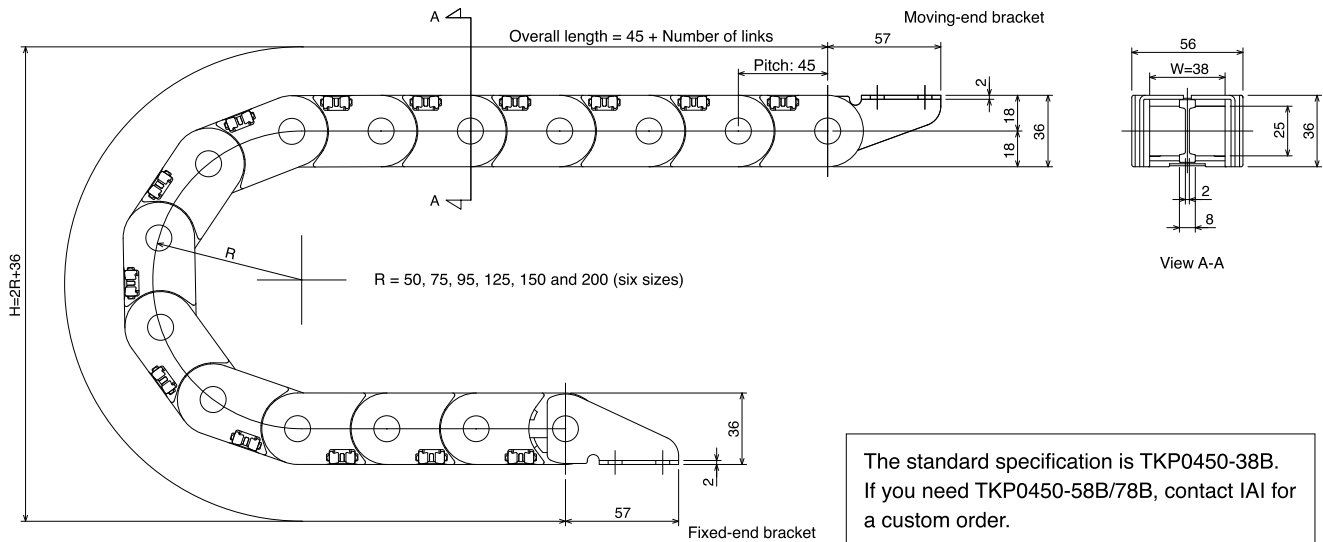

Specified Product **TKP0450-58B/TKP0450-78B**  
(Manufacturer: Tsubakimoto Chain)

TKP0450 – 58B

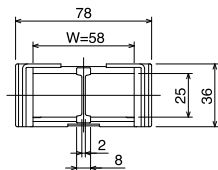

TKP0450 – 78B

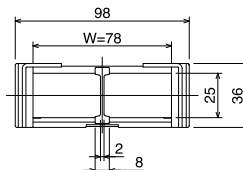

View A-A

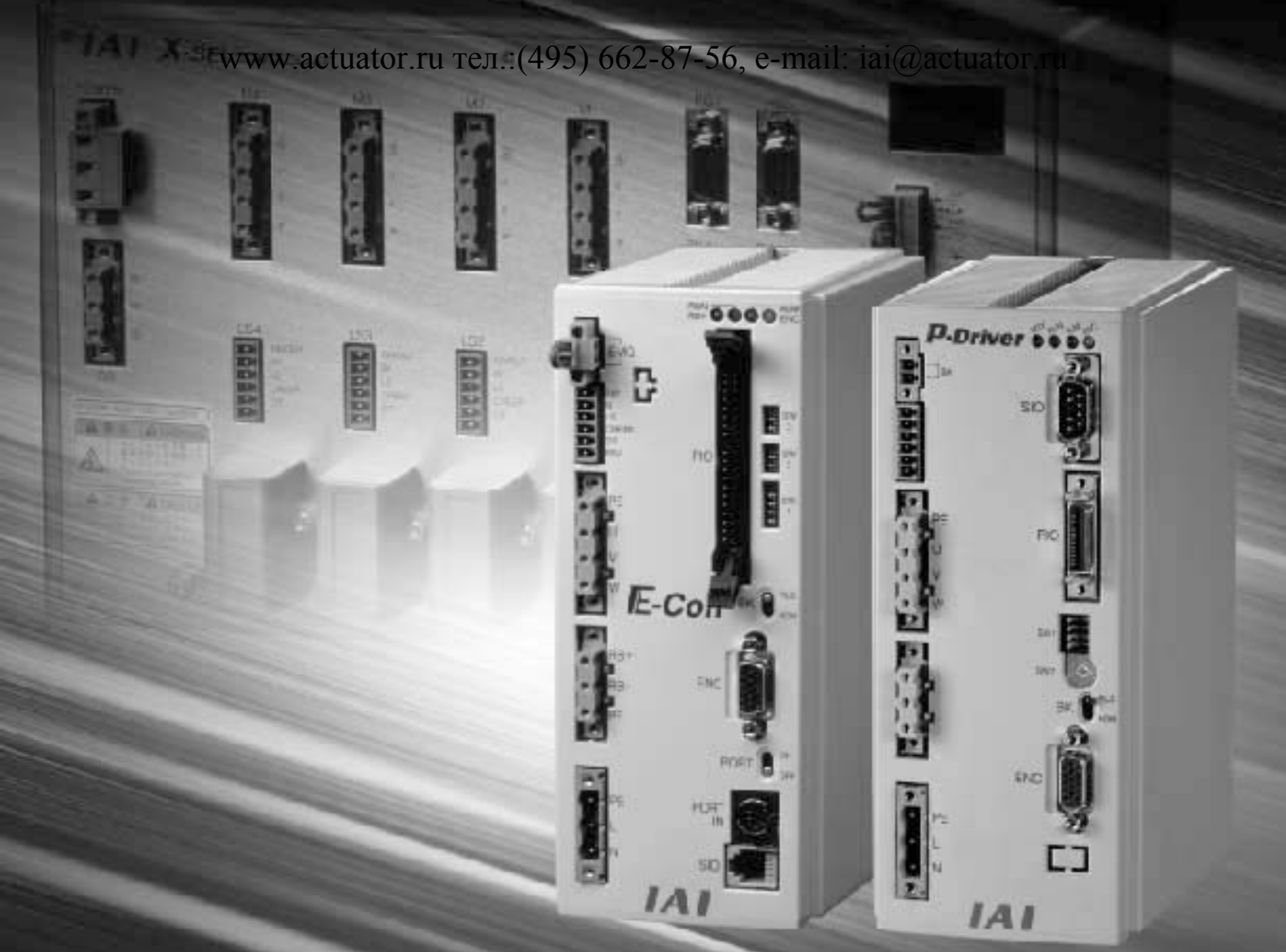

Quality and Innovation

# Controllers

**E-Con**  
**P-Driver**  
**XSEL-J/K/KE**

Single-Axis Only	Dedicated Controller for Positioner Operation	Single-Axis Robot Controller	<b>E-Con</b>	227
	Positioning Driver with Pulse-Train Input	Single-Axis Robot Controller	<b>P-Driver</b>	234
Single-Axis/Multi-Axes	General-Purpose Controller for Program Operation	Single-Axis/Cartesian Robot Controller	<b>XSEL-J/K/KE</b>	241

# E-Con

Position Controller for Single-Axis Robot

Operating method	Positioner operation
Number of storable positions	64 positions
Supply voltage	100/200 VAC, selectable



## 1 Features

### 1 Driving High-Performance Single-Axis Robot IA Series

The E-Con is able to drive the various actuators in the IA Series.

#### ■ Drivable Actuator Specifications

Stroke	Control output	Maximum speed	Maximum load capacity	Maximum load capacity
100 ~ 3000 mm	20W ~ 750W	2000 mm/sec	150 kg (horizontal)	60 kg (vertical)

### 2 Positioning to Maximum 64 Points with Easy Operation

Operation is easy. Simply store the target positions as position data and specify the applicable position numbers from a PLC, etc. There is no need to create a complicated program.

Number of positioning points: 64

Positions can be entered in the following three ways:

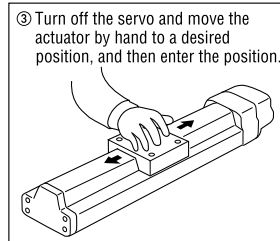
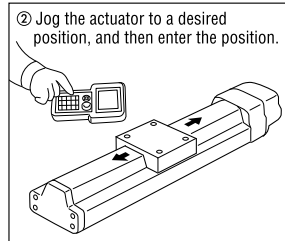
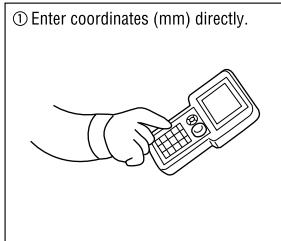

### 3 Incremental/Absolute Specifications

The E-Con supports the absolute specification that will retain the current position even after the power is turned off. Your equipment can therefore be operated immediately after startup or upon reset following an emergency stop.

You can also select the conventional incremental specification.

### 4 Wide-Ranging Functions

The E-Con provides a range of functions beyond normal positioning.

The desired functions can be combined to accommodate various applications.

E-Con Function	E-Con Function	E-Con Function	E-Con Function	E-Con Function	E-Con Function	E-Con Function
Incremental moves	Pause	Zone output	Acceleration only MAX	Positioning band	Speed variation	Serial communication

(Refer to the Robo Cylinder catalog for the details of each function.)

### 5 Supporting Various Field Networks

The E-Con, with its wire-saving design, can connect to many different field networks for communication with equipment from various manufacturers without the need for cumbersome wiring.

\* Consult IAI beforehand if you are considering a Profibus connection.

### 6 Conformance with the CE Mark

\* Contact IAI for details.



2 Model

**ECON - 1 - 750BL - DV - 2 - EU - P**

① ② ③ ④ ⑤ ⑥ ⑦

① Series	② Encoder type	③ Connected axis details (1 axis only)				④ Network	⑤ Supply voltage	⑥ CE compliance	⑦ I/O signal type (Note 2)
		Motor capacity (Note 1)	Brake	Creep	Limit switch				
ECON	I (Incremental)  A (Absolute)	20 (20W)	Not specified (Without brake)  B (With brake)	Not specified (Without creep sensor)  C (With creep sensor)	Not specified (Without limit switch)  L (With limit switch)	Not specified (Network not supported)  DV (DeviceNet specification)  CC (CC-Link specification)  PR (Profibus specification)	1 (100V)  2 (200V)	Not specified (Standard specification)  EU (CE-compliant)	Not specified (NPN)  P (PNP)
		30 (30W)							
		60 (60W)							
		100 (100W)							
		150 (150W)							
		200 (200W)							
		300 (300W)							
		400 (400W)							
600 (600W)									
750 (750W)									

(Note 1) 20/30-watt specifications will be available from October 2003.

(Note 2) Even when you have selected a CE-compliant specification, be sure to specify NPN or PNP as the I/O signal type.

3 System Configuration Diagram

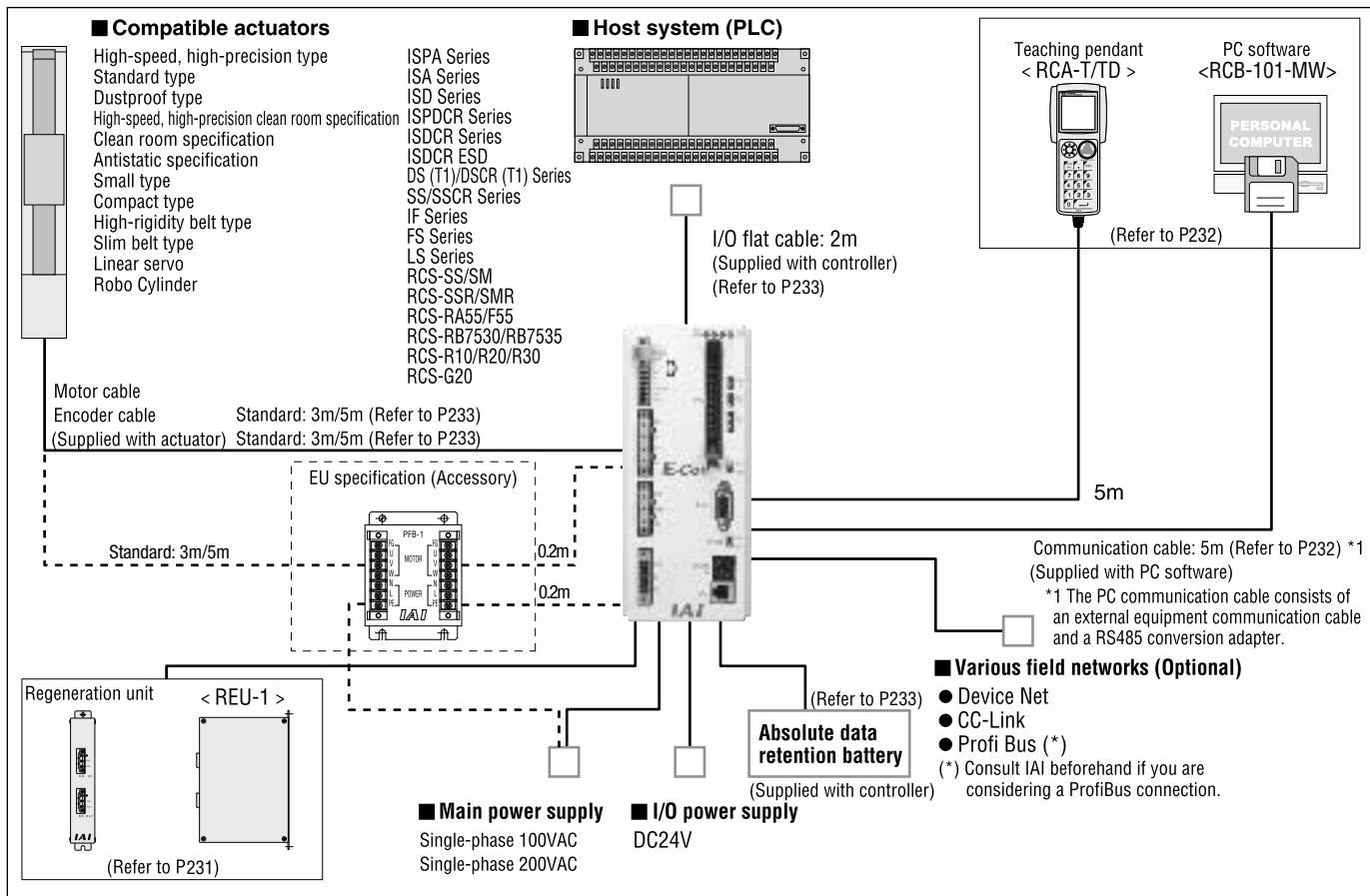

**EU Specification Details**

The E-Con's EU specification comes with the following filter box (model: PFB-1) and dedicated cable for noise elimination purposes.

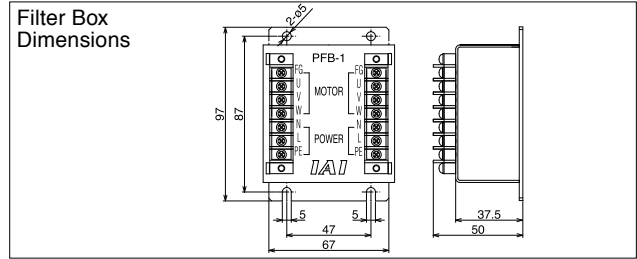
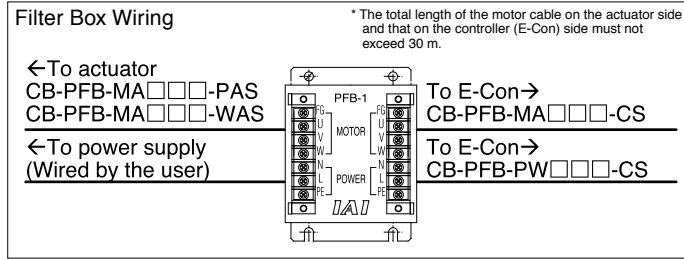

**Actuator Motor Cable (Robo Cylinder)**

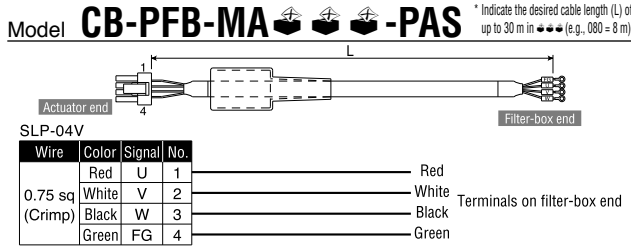

**Actuator Motor Cable (Single-Axis Robot)**

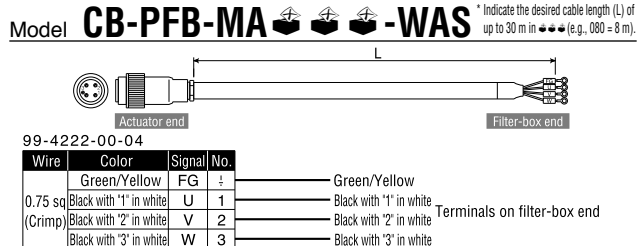

**Controller Motor Cable (Common to All Models)**

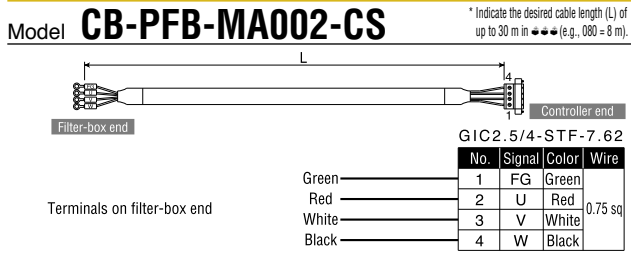

**Controller Power Cable (Common to All Models)**

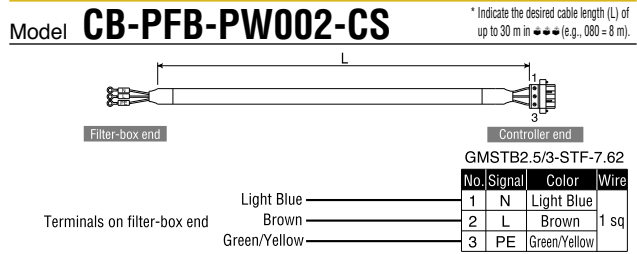

**4 I/O Wiring**

**RCS-C Type (Insulated I/O Specification)**

**Input Part** 24-V external I/O specification

Item	Specification
Number of input points	10 points
Input voltage	24VDC ±20%
Input current	7mA/point
Operating voltage	ON voltage --- Min. 16V (4.5mA) OFF voltage --- Max. 6V (1.4mA)
Insulation method	Photocoupler

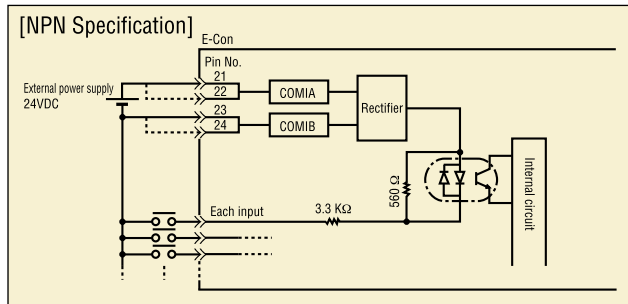

- Supply 24 VDC to COMIA or COMIB. COMIA and COMIB have no polarity.
- Connect the negative side of the external power supply to the common side of the input.
- Pin Nos. 21 and 22 of COMIA, and pin Nos. 23 and 24 of COMIB, are connected internally.

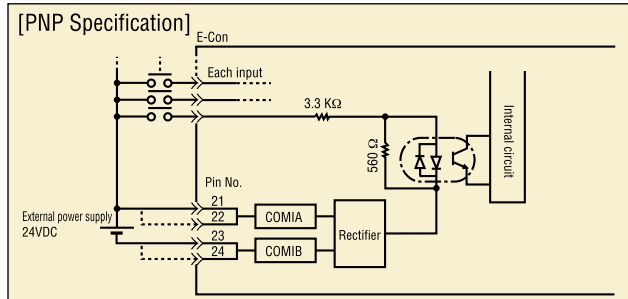

- Supply 24 VDC between COMOA and COMOB. COMOA and COMOB have no polarity.
- Connect the positive side of the external power supply to the common side of the input.
- Pin Nos. 21 and 22 of COMIA, and pin Nos. 23 and 24 of COMIB, are connected internally.

**Output Part** 100-mA output circuit by Power MOSFET

Item	Specification
Number of output points	13 points
Rated load voltage	24VDC/60V (peak) (No flywheel diode)
Maximum load current	100mA/point
Insulation method	Photocoupler
Leak current	Fuse resistance: 10Ω, 0.1W

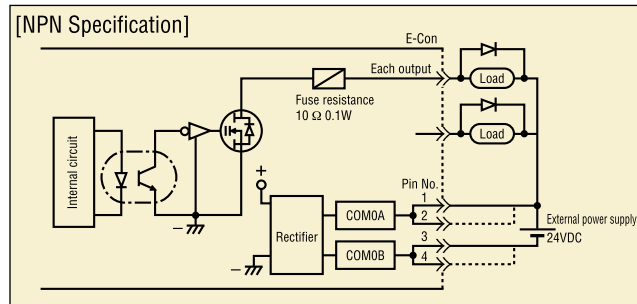

- Supply 24 VDC to COMIA or COMIB. COMIA and COMIB have no polarity.
- Pin Nos. 1 and 2, and pin Nos. 3 and 4, are connected internally.
- Note 1) The output circuit uses a Power MOSFET open drain and has no flywheel diode. Be sure to provide a fly-back voltage inhibition measure using a diode, etc., for the load L of a relay, etc. (Inserting a diode in a position as close as possible to the coil is the most effective way to prevent spike noise.)

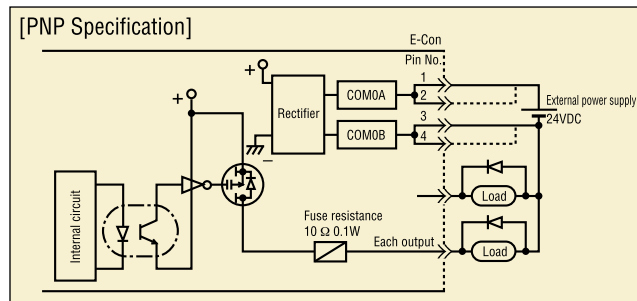



5 I/O Signal Table

E-Con

Pin No.	Category	Signal name	Description	Pin No.	Category	Signal name	Description
1		COM-0A	Output port power (Note 1)	21		COM-IA	Input port power (Note 2)
2		COM-0A		22		COM-IA	
3		COM-0B		23		COM-IB	
4		COM-0B		24		COM-IB	
5	Output (Note 3)	NC	Not used	25	Input (Note 3)	NC	Not used (Do not connect anything)
6		NC	(Do not connect anything)	26		NC	
7		*Battery alarm	Battery alarm (Contact B)	27		NC	
8		NC	Not used	28		NC	
9		Moving	Moving output	29		NC	
10		PM32	Position complete output 32	30		PC32	Specified position input 32
11		*EMG	Emergency-stop output (Contact B)	31		NC	Not used (Do not connect anything)
12		PM16	Position complete output 16	32		PC16	Specified position input 16
13		*ALM	Alarm output (Contact B)	33		*ILK	Pause input (Contact B)
14		PM8	Position complete output 8	34		PC8	Specified position input 8
15	ZONE	Zone	35	SVON	Servo ON input		
16	PM4	Position complete output 4	36	PC4	Specified position input 4		
17	ZFIN	Home complete output	37	RESET	Reset input		
18	PM2	Position complete output 2	38	PC2	Specified position input 2		
19	PFIN	Position complete output	39	CSTR	Start input		
20	PM1	Position complete output 1	40	PC1	Specified position input 1		

(Note 1) Connect the 24-VDC power supply between COM-0A and COM-0B. COM-0A and COM-0B have no polarity. Pin Nos. 1 and 2, and pin Nos. 3 and 4, are connected internally.

(Note 2) Connect the positive side of the 24-VDC power supply to either COM-IA or COM-IB (pin Nos. 21 through 24). COM-IA and COM-IB have no polarity. Pin Nos. 21 and 22, and pin Nos. 23 and 24, are connected internally.

(Note 3) The ports indicated by \* conform to the contact B signal logic (always ON).  
Never connect the ports denoted "Not used."

6 Specification Table

Item	Description							
Controller series/type	ECON							
Compatible actuators	ISA, ISPA, ISD, ISDCR (ESD), ISPDGR, DS, DSCR, SS, SSCR, IF, FS, LS RCS-SS/SSR/SM/SMR/RA55/F55/R10/R20/R30/G20							
Applicable motor capacity (W)	60	100	150	200	300	400	600	750
Number of controlled axis	1 axis only							
Maximum output of connected axis (W)	750							
Power supply	100-V specification: Single-phase 100~115VAC 200-V specification: Single-phase 200~230VAC				200-V specification: Single-phase 200~230VAC			
Power supply voltage range	±10%							
Power frequency	50/60Hz							
Power capacity (Note 1)	100W 160VA	150W 240VA	210W (290W) 350VA (490W)	270W 450VA	(410W) (680VA)	520W 870VA	770W 1300VA	1000W 1600VA
Position detection method	Incremental encoder/absolute encoder							
Speed setting	1 mm/s or more; upper limit determined by the actuator specification							
Acceleration setting	0.01G or more; upper limit determined by the actuator specification							
Program language	-							
Number of programs	-							
Number of program steps	-							
Number of multitask programs	-							
Number of positions	64							
Data storage device	EEPROM							
Data input method	Teaching pendant, PC software							
Standard I/Os	10 dedicated inputs/12 dedicated outputs							
Expanded I/Os	Not expandable							
Serial communication function	Comes standard with a RS485 port.							
Other I/Os	Emergency-stop input (contact-B terminal block)							
Protective functions	Motor overvoltage, motor overcurrent, motor overload, driver temperature error, encoder error, etc.							
Operating temperature/humidity	Temperature: 0~40°C, humidity: 85%RH or less							
Operating environment	Not subject to corrosive gases or significant dust.							
Weight	1.2kg <Incremental type> 1.5kg <Absolute type>							
Accessory	PIO flat cable (2m)							

(Note 1) The figures in parentheses apply only to the LS type (linear servo actuator).

## 6 External Dimensions

Controller  
**E-Con**

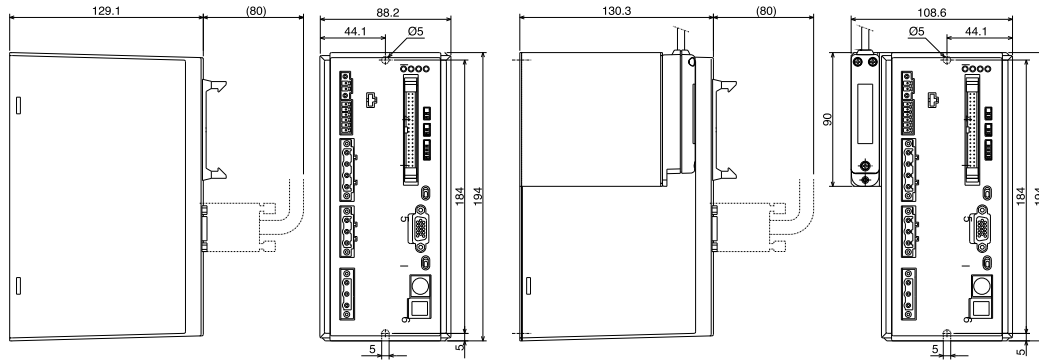

External view of incremental specification

External view of absolute specification

## 7 Name and Function of Each Part

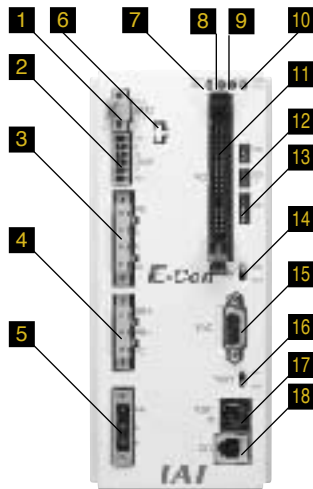

### 1 EMG terminal

A connector for the emergency-stop switch. The controller will actuate an emergency stop when this connector becomes open.

### 2 Actuator-sensor input connector

An input terminal for the LS, CREEP or OT sensor, etc., installed on the actuator. The pins are assigned to 24V, N, LS, CREEP and OT from the top. Use a dedicated cable for connection.

### 3 Motor cable connector

A connector for the actuator's motor power cable. The pins are assigned to PE, U, V and W from the top. Use a dedicated cable for connection.

### 4 Regeneration resistor unit connector

A connector for the regeneration resistor unit. The pins are assigned to RB+, RB- and PE from the top.

### 5 Main power input connector

A connector for the controller power. The pins are assigned to PE, L and N from the top.

### 6 Absolute battery connector

A connector for the battery unit to be used with an ABS actuator.

### 7 ~ 10 Indicator LEDs

These LEDs indicate the controller condition. The details of each LED are as follows:

- 7 RDY (Green) Lit when the controller is operating normally.
- 8 RUN (Green) Lit during movement.
- 9 ALM (Red) Lit while an alarm is present.
- 10 ENC (Orange) Lit if the encoder is open or cannot be recognized.

### 11 PIO connector

A 40-pin connector for parallel communication with a PLC, etc.

### 12 DIP switch (SW2)

A data setting switch for rotation data clear and remote update used on an ABS actuator. Refer to the explanation below for the function/setting corresponding to each switch number:

SW2-1 ON to enable rotation data clear

SW2-2 ON to enable remote update

### 13 DIP switch (SW1)

An axis ID setting switch.

### 14 Brake release switch

RLS Brake is forcibly released.

NOM Brake is in use (normal setting).

### 15 Encoder cable connector

A connector for the actuator's encoder cable.

### 16 Port switch

A switch for enabling/disabling Termi-Bus communication with a teaching pendant or PC.

### 17 Main communication port connector

A connector for Termi-Bus communication with a teaching pendant or PC. It also serves as a link cable connector when multiple controllers are connected.

### 18 SIO connector

A connector for linking multiple controllers.

## 8 Options

### Regeneration Resistor Unit

Model **REU-1**

#### Description

This unit converts to heat the regenerative current generated when the motor decelerates. A regeneration resistor is provided inside the controller, but its capacity may not be sufficient when a large load is applied to the vertical axis. In this case, this optional unit is required. (Refer to the table at bottom right.)

#### Specification

Item	Specification
Dimensions	W34mm X H195mm X D126mm
Weight	0.9kg
Built-in regeneration resistor	220Ω 80W
Accessory	Controller link cable (model: CB-ST-REU010), 1m

#### Installation Standards

Motor output	Horizontal use	Vertical use
0~150W		Not required.
200~600W	Not required.	1 unit is required.
750W		2 units are required.

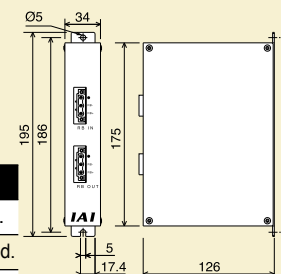

\* The above are reference settings assuming the rated conditions (load capacity, speed and acceleration).

9 Options

Teaching Pendant

Model

**RCA-T** (Standard) **RCA-TD** (With deadman switch)

Features

- A teaching device that provides all of the functions needed for test operation/adjustment, such as position-data input, test operation and monitoring of the current axis position and I/O signals.
- The interactive-type panel ensures easy operation. All you need is to enter values in the required fields, so you won't need the operation manual for basic operations.

Specification

Items	Specification
Operating temperature, humidity	Temperature: 0~40°C, humidity: 85%RH or less
Operating environment	Not subject to corrosive gases or significant dust.
Weight	Approx. 550g (including cable)
Cable length	5m
Display	21 characters x 16 lines, LCD

Dimensions

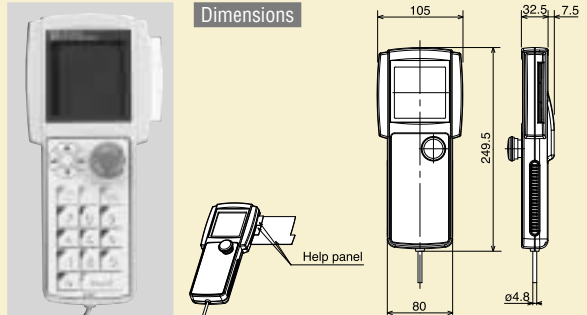

Data Setting Unit

Model

**RCA-P** \*Operations involving axis movement cannot be performed.

Features

An affordable data setting unit offering edit functions, except for operations involving axis movement.

- Edit functions
- Position data input
  - Confirmation of current axis position
  - I/O signal monitoring, etc.

Specification

Items	Specification
Operating temperature, humidity	Temperature: 0~40°C, humidity: 85%RH or less
Operating environment	Not subject to corrosive gases or significant dust.
Weight	Approx. 360g
Cable length	5m
Display	16 characters x 2 lines, LCD

Dimensions

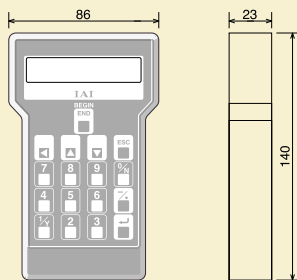

External Equipment Communication Cable

Model **CB-RCA-SIO050**

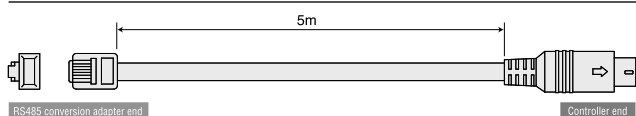

Color	Signal	No.	No.	Signal	Color
Brown	5V	1	1	SGA	Yellow
Yellow	SGA	2	2	SGB	Orange
Red	GND	3	3	5V	Brown/Green
Orange	SGB	4	4	EMGS	-
Blue	GND	5	5	EMGA	Black
Green	5V	6	6	24V	-
			7	GND	Red/Blue
			8	EMGB	Black
				FG	Shielded

Shorting wire: UL1007 AWG28 (black)  
Shielded, not connected

Simple Teaching Pendant

Model

**RCA-E**

Features

- A highly cost-effective teaching pendant that provides the same functions as the RCA-T at a significantly lower price.
- The unit size has been reduced through the use of a two-line display.

Specification

Items	Specification
Operating temperature, humidity	Temperature: 0~40°C, humidity: 85%RH or less
Operating environment	Not subject to corrosive gases or significant dust.
Weight	Approx. 400g (including cable)
Cable length	5m
Display	16 characters x 2 lines, LCD

Dimensions

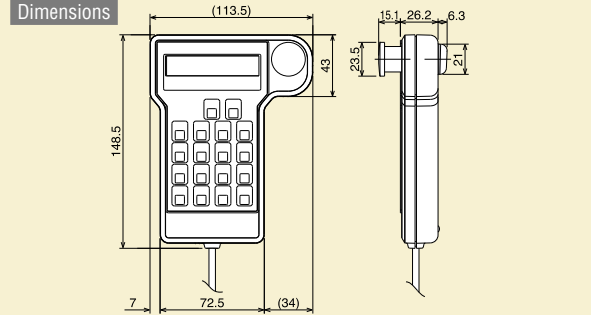

PC Software

Model

**RCB-101-MW** (DOS/V, Windows version)

[Content] Floppy disk, PC communication cable (5m) (\*1)

Features

- A support software for position data input and test operation.
- This software significantly improves the equipment debugging operations by offering wide-ranging functions such as jogging, inching, step operation and continuous operation, and also by allowing easy operation via a large PC screen.



(\*1) The PC communication cable consists of CB-RCA-SIO050 and RCB-CV-MW (refer to the drawing below).

RS485 Conversion Adapter

Model **RCB-CV-MW**

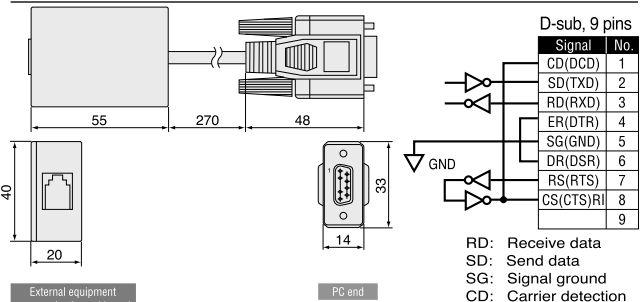

9 Service Parts

Motor Cable (Single-Axis Robot Connection)

Model **CB-X-MA** \* Indicate the desired cable length (L) of up to 30 m in (e.g., 080 = 8 m).  
Compatible actuators: DS/DSCR/ISP/IS/ISD/IF/FS/SS/SSCR/SPDCR/ISDCR/ISDCR-ESD

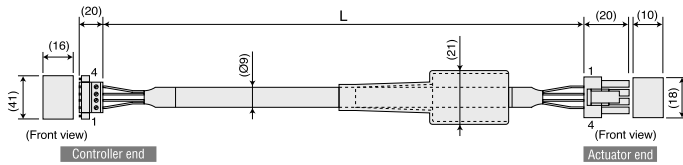

Wire	Color	Signal	No.	No.	Signal	Color	Wire
0.75 sq	Green	PE	1	1	U	Red	0.75 sq (Crimp)
	Red	U	2	2	V	White	
	White	V	3	3	W	Black	
	Black	W	4	4	PE	Green	

Motor Cable (Robo Cylinder/Linear Connection)

Model **CB-RCC-MA** \* Indicate the desired cable length (L) of up to 30 m in (e.g., 080 = 8 m).  
**CB-RCC-PA** -RB (Linear Servo)  
Compatible actuators: RCS-SS/SM/SSR/SMR/RA55/RB-7530/RB-7535/F55/G20/R10/R20/R30/LS

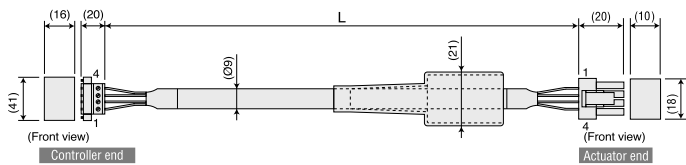

Wire	Color	Signal	No.	No.	Signal	Color	Wire
0.75 sq	Green	PE	1	1	U	Red	0.75 sq (Crimp)
	Red	U	2	2	V	White	
	White	V	3	3	W	Black	
	Black	W	4	4	PE	Green	

Encoder Cable (Single-Axis Robot Connection)

Model **CB-X-PA** \* Indicate the desired cable length (L) of up to 30 m in (e.g., 080 = 8 m).  
Compatible actuators: DS/DSCR/ISP/IS/ISD/IF/FS/SS/SSCR/SPDCR/ISDCR/ISDCR-ESD

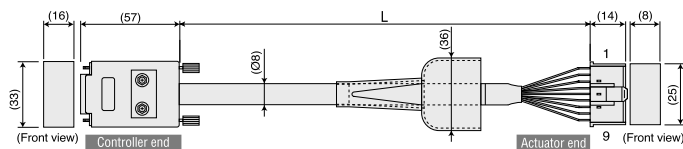

Wire	Color	Signal	No.	No.	Signal	Color	Wire
0.15 sq (Crimp)	-	-	1	1	BAT+	Black	0.15 sq (Crimp)
	-	-	2	2	BAT-	Yellow	
	-	-	3	3	SD	Blue	
	-	-	4	4	SD	Orange	
	-	-	5	5	VCC	Green	
	-	-	6	6	GND	Brown	
	Blue	SD	7	7	-	-	
	Orange	SD	8	8	-	-	
	Black	BAT+	9	9	FG	Ground	
	Yellow	BAT-	10	10	SD	Blue	
	Green	VCC	11	11	SD	Orange	
	Brown	GND	12	12	BAT+	Black	
	Gray	BK-	13	13	BAT-	Yellow	
	Red	BK+	14	14	VCC	Green	
	-	-	15	15	GND	Brown	

Connect the shielded wire to the hood using a clamp. Ground wire and shielded wire, braided.

Encoder Cable (Robo Cylinder/Linear Connection)

Model **CB-RCBC-PA** \* Indicate the desired cable length (L) of up to 30 m in (e.g., 080 = 8 m).  
**CB-RCBC-PA** -RB (Linear Servo)  
Compatible actuators: RCS-SS/SM/SSR/SMR/RA55/RB-7530/RB-7535/F55/G20/R10/R20/R30/LS

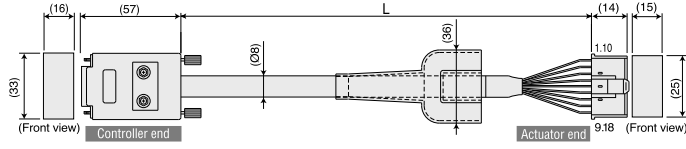

Wire	Color	Signal	No.	No.	Signal	Color	Wire
0.15 sq (Crimp)	Pink	A/U	1	1	A/U	Pink	0.15 sq (Crimp)
	Purple	A/U	2	2	A/U	Purple	
	White	B/V	3	3	B/V	White	
	Blue/Red	B/V	4	4	B/V	Blue/Red	
	Orange/White	Z/W	5	5	Z/W	Orange/White	
	Green/White	Z/W	6	6	Z/W	Green/White	
	Blue	SD	7	7	-	-	
	Orange	SD	8	8	-	-	
	Black	BAT+	9	9	FG	Ground	
	Yellow	BAT-	10	10	SD	Blue	
	Green	VCC	11	11	SD	Orange	
	Brown	GND	12	12	BAT+	Black	
	Gray	BK-	13	13	BAT-	Yellow	
	Red	BK+	14	14	VCC	Green	
	-	-	15	15	GND	Brown	
	-	-	16	16	-	-	
	-	-	17	17	BK-	Gray	
	-	-	18	18	BK+	Red	

Connect the shielded wire to the hood using a clamp. Ground wire and shielded wire, braided.

Limit Switch Cable (Single-Axis Robot Connection)

Model **CB-X-LC**

\* Indicate the desired cable length (L) of up to 30 m in (e.g., 080 = 8 m).

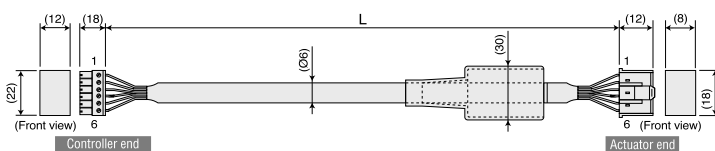

Wire	Color	Signal	No.	No.	Signal	Color	Wire
AWG24	Light Blue	24VOUT	6	1	24VOUT	Light Blue	AWG24 (Crimp)
	Pink	N	5	2	N	Pink	
	Grass	LS	4	3	LS	Grass	
	Orange	CREEP	3	4	CREEP	Orange	
	Gray	OT	2	5	OT	Gray	
	1B/Light Blue	RSV	1	6	RSV	1B/Light Blue	

Note) "1B" indicates one black dot mark.

I/O Flat Cable (E-Con)

Model **CB-RCBC-PI0020**

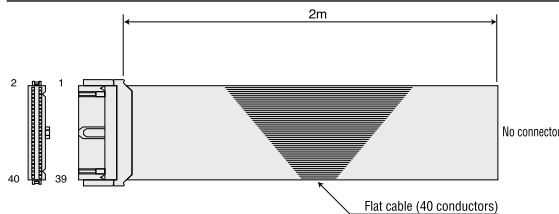

No.	Color	Signal name	No.	Color	Signal name	No.	Color	Signal name	No.	Color	Signal name
1	Brown-1	COM-0A	11	Brown-2	/EMG	21	Brown-3	COM-1A	31	Brown-4	NC
2	Red-1	COM-0A	12	Red-2	PM16	22	Red-3	COM-1A	32	Red-4	PC16
3	Orange-1	COM-0B	13	Orange-2	/ALM	23	Orange-3	COM-1B	33	Orange-4	/ILK
4	Yellow-1	COM-0B	14	Yellow-2	PM8	24	Yellow-3	COM-1B	34	Yellow-4	PC8
5	Green-1	NC	15	Green-2	ZONE	25	Green-3	NC	35	Green-4	SVON
6	Blue-1	NC	16	Blue-2	PM4	26	Blue-3	NC	36	Blue-4	PC4
7	Purple-1	NC	17	Purple-2	ZFIN	27	Purple-3	NC	37	Purple-4	RESET
8	Gray-1	Battery alarm	18	Gray-2	PM2	28	Gray-3	NC	38	Gray-4	PC2
9	White-1	Moving	19	White-2	PFIN	29	White-3	NC	39	White-4	CSTR
10	Black-1	PM32	20	Black-2	PM1	30	Black-3	PC32	40	Black-4	PC1

Absolute Data Retention Battery

Model **AB-1**



\* Case is not included.

Specification

Item	Description
Battery type	Lithium battery
Battery capacity	2000mAh
Data retention time	Approx. 20,000 hours
Nominal voltage	3.6V

Compatible controllers: RCS-E/RCS-C/E-Con

# P-Driver

Positioning Driver with Pulse-Train Input

Operating method      Pulse-train control  
Supply voltage         100/200 VAC, selectable



## 1 Features

### 1 Effective Control of Robo Cylinder and IAI's Single-Axis Robot with Pulse Train

The P-Driver lets you operate a variety of Robo Cylinders and single-axis robots (motor output: 20 to 750 W; stroke: 50 to 3000 mm) as desired. It offers a dramatic cost savings because design, assembly and adjustment are much simpler than when building a system combining individual components such as a ball screw and motor. Furthermore, pulse-train control does not limit the number of positioning points.

### 2 Dedicated Homing Signal

The dedicated homing input allows for automatic homing, thereby eliminating the need to program a complicated sequence.

### 3 Torque Limiting Function

Torque can be limited via external signal (based on parameter setting). When the specified torque is reached, a signal will be output. This function lets you implement push & hold, press-fitting and other operations.

### 4 Brake Control Function

Control of the actuator brake (actuator option) uses a dedicated circuit within the controller. There is no need to program a separate sequence.

By providing a dedicated power supply (24 VDC), the brake can be forcibly released even when the driver's main power supply is cut off.

### 5 Feedback Function

Position detection data can be output in pulse train (differential output) form. This allows the host controller to read the current position in real time (up to 115 kpps).

### 6 Feed-Forward Control Function

Response can be increased under certain conditions, such as when the load's inertia ratio is high. Increasing the parameter value will reduce the deviation (the difference between the commanded position and the position fed back), thus increasing response.

### 7 Primary Position-Command Filter Function

Soft start and stop is possible even in the command pulse input mode where acceleration/deceleration is not considered.

## 2 Model

**PDR - 1 - 750BL - 2 - P**

①      ②      ③      ④      ⑤

① Series	② Encoder type	③ Connected axis details (1 axis only)				④ Supply voltage	⑤ I/O signal specification
		Motor capacity	Brake	Creep	Limit switch		
PDR	I (Incremental)	20 (20W)	Not specified (Without brake)  B (With brake)	Not specified (Creep not supported)  C (Creep supported)	Not specified (Limit switch not supported)  L (Limit switch supported)	1 (100V)	Not specified (NPN)
		30 (30W)					
		60 (60W)					
		100 (100W)					
		150 (150W)					
		200 (200W)				2 (200V)	P (PNP)
		400 (400W)					
		600 (600W)					
		750 (750W)					
		750 (750W)					

**3 System Configuration Diagram**

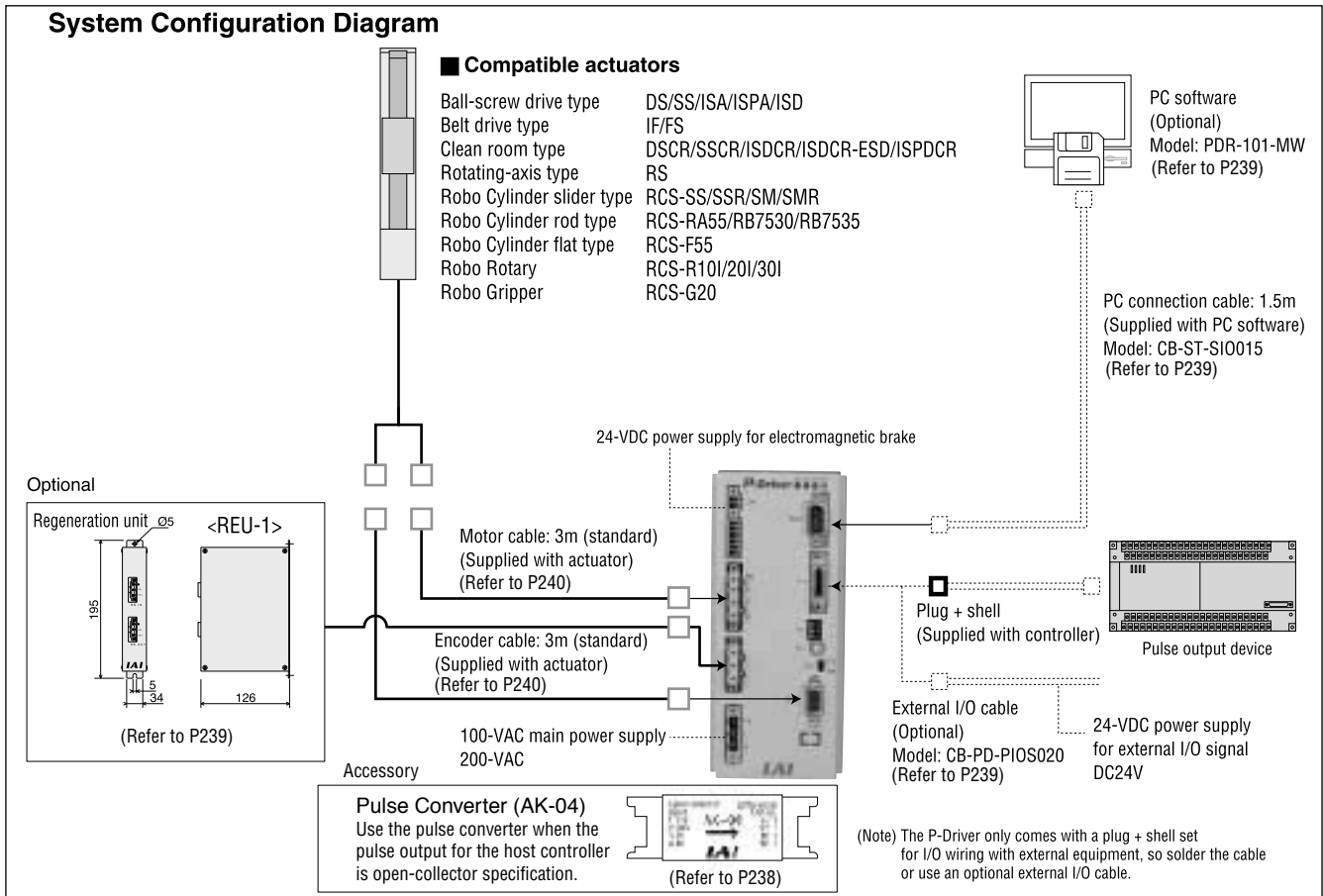

**4 I/O Wiring**

**Input Part** Sequence input specification

Item	Specification
Number of input signals	5 points
Input voltage	24VDC $\pm 20\%$
Input current	7mA/point
Operating voltage	ON voltage --- Min. 16V (4.5mA) OFF voltage --- Max. 6V (1.4mA)
Insulation method	Photocoupler

**Output Part** Sequence output specification

Item	Specification
Number of output signals	6 points
Rated load voltage	24/60VDC (Peak; no flywheel diode)
Maximum load current	100mA/point
Insulation method	Photocoupler
Overcurrent protection	Fuse resistance: 10 $\Omega$ , 0.1W

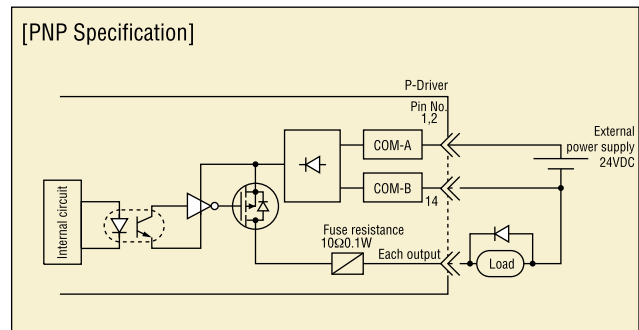
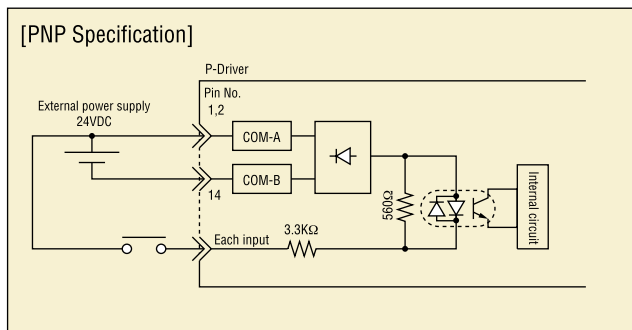
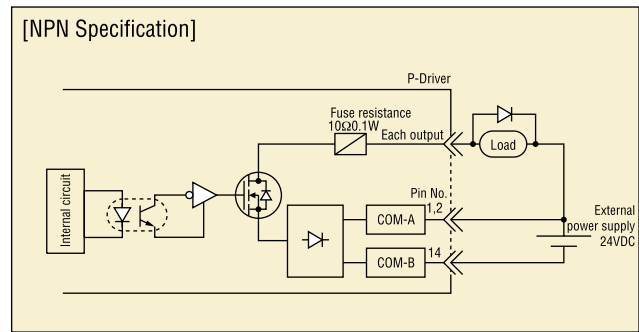
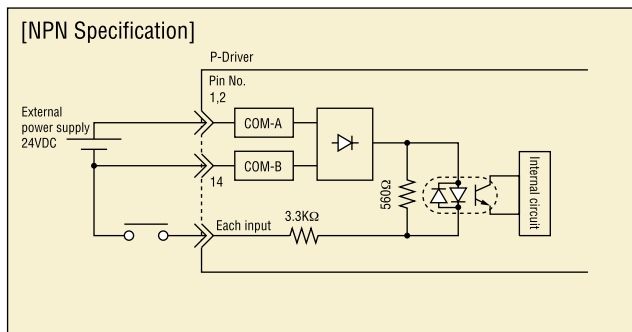

5 I/O Signal Table

Pin No.	I/O category	Signal abbreviation	Signal name	Function
1	External I/O signal power	COM-A	Power common (+)	Connect to the positive side of the 24-VDC power supply common for external I/O signal. (Pins 1 and 2 are connected internally.)
2		COM-A		
3	Sequence signal output	SRDY	System ready	After the power is turned ON, this signal will turn ON when the P-Driver becomes control-ready. It is synchronized with the ON/OFF of the corresponding LED on the front panel of the enclosure.
4		RUN	Operation ready	This signal will turn ON when the servo is turned ON (the actuator is operation-ready). It is synchronized with the ON/OFF of the corresponding LED on the front panel of the enclosure.
5		INP	Position complete	This signal will turn ON when the actuator enters the in-position range set by the applicable parameter.
6		ORGR	Homing complete	This signal will turn ON when homing is completed.
7		TLR	Torque limiting	This signal will turn ON when the actuator output reaches the parameter-set torque limit while TL is ON.
8		ALM	Alarm	This signal will turn OFF when a protective circuit (function) has actuated and the base current is cut off (the signal is normally ON).
9	Sequence signal input	SON	Servo ON	The actuator is ready to operate when this signal turns ON (servo ON state).
10		RES	Alarm reset	An alarm will be reset when this signal is turned ON.
11		ORGC	Homing command	Homing will start when this signal is turned ON.
12		TL	Torque limiting selection	Actuator-torque limiting will start when this signal is turned ON. (Turning this signal OFF will cancel torque limiting.)
13		CSTP	Forced stop	When this signal is turned ON, the actuator will be decelerated to a stop by forced stopping torque and the servo will turn OFF.
14		External I/O signal power	COM-B	Power common (-)
15	Command pulse input	NP	Pulse-train input	Command pulse-train input: Open-collector mode (Max. 200 kpps), Differential - receiver mode (Max. 500 kpps) Command pulse format is selectable from 6 types via parameter.
16		/NP		
17		PP		
18		/PP		
19	Feedback pulse differential output	AFB	+A	Position detection data is output as pulses (phases A, B and Z). Pulse output format is selectable from 6 types via parameter.
20		/AFB	-A	
21		BFB	+B	
22		/BFB	-B	
23		ZFB	+Z	
24		/ZFB	-Z	
25	Reference potential	GND	Reference potential	For feedback pulse output
26		GND		Line-driver ground line (Pins 25 and 26 are connected internally.)

6 Standard Connection Diagram

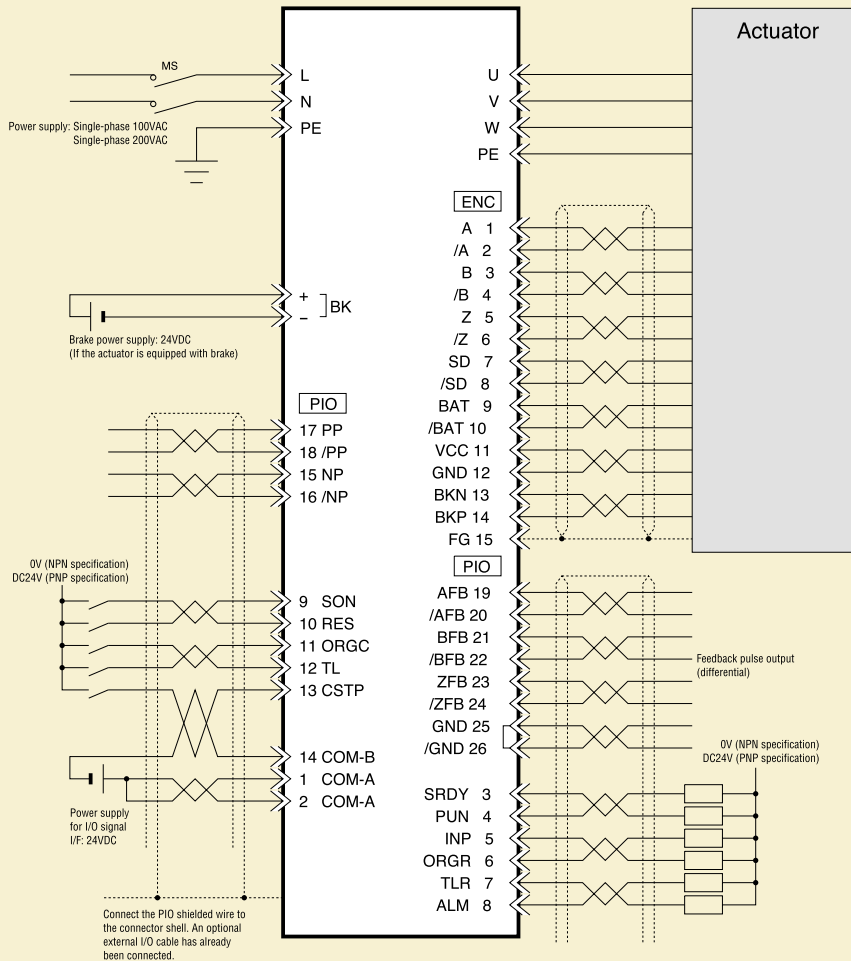

**7 Position Controller for Single-Axis Robot**

**Input by Differential Line Driver**

Applicable line driver: 26C31 or equivalent

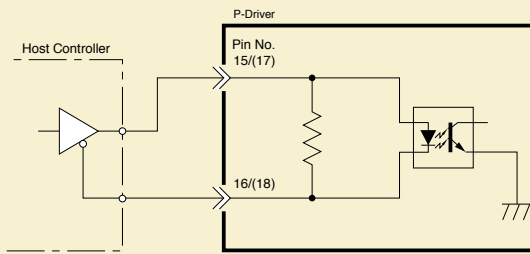

**Input by Open Collector**

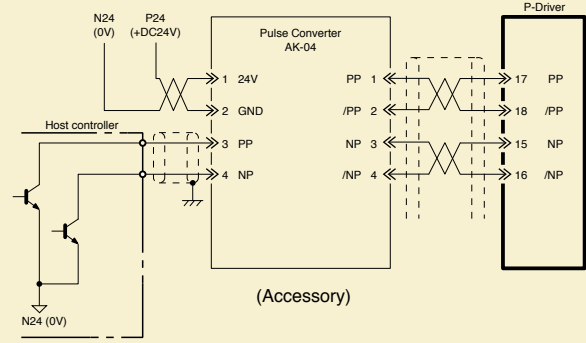

**Feedback Pulse Output**

Applicable line receiver: 26C32 or equivalent

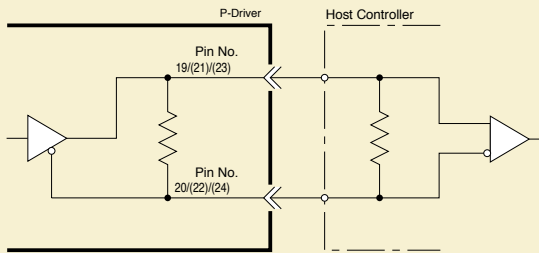

**Caution**

- Thoroughly confirm the compatibility with the host controller.
- If noise generation is a possibility, select a host controller that uses differential line-driver output.

**8 Command Pulse Input Format**

		Command pulse-train format	Input terminal	Forward	Reverse	
Negative logic	Forward pulse train		PP•/PP			
	Reverse pulse train		NP•/NP			
	A forward pulse train indicates motor revolutions in the forward direction, while a reverse pulse train indicates motor revolutions in the reverse direction.					
	Pulse train		PP•/PP			
	Sign		NP•/NP	Low	High	
Command pulses indicate motor revolutions, while a command sign indicates direction of rotation.						
Positive logic	Phase A/B pulse train		PP•/PP			
			NP•/NP			
	Phase A/B (4x multiplication) pulses of 90° phase difference command revolutions and direction of rotation.					
	Forward pulse train		PP•/PP			
	Reverse pulse train		NP•/NP			
	Pulse train		PP•/PP			
	Sign		NP•/NP	High	Low	
	Phase A/B pulse train		PP•/PP			
			NP•/NP			

\* The same output formats apply to feedback pulses.



9 Specification Table

Item	Description									
Controller series/type	PDR									
Compatible actuators	DS, SS, ISA, ISPA, ISD, ISDCR, ISPDRCR, IF, FS RCS-SS/SSR/SM/SMR/RA55/F55/G20/R10/R20/R30									
Applicable motor capacity (W)	20	30	60	100	150	200	400	600	750	
Number of controlled axis	1 axis only									
Maximum output of connected axis (W)	750									
Power supply	100-V specification: Single-phase 100~115VAC					200-V specification: Single-phase 200~230VAC				
Power supply voltage range	±10%									
Power frequency	50/60Hz									
Power capacity	34W	42W	100W	150W	210W	270W	520W	770W	1000W	
	57VA	70VA	160VA	240VA	350VA	450VA	870VA	1300VA	1600VA	
Control method	Sine wave PWM, vector current control									
Position detection method	Incremental encoder									
Drive system	Regeneration resistor									
Function performance	Control mode	Position control by pulse-train input								
	Maximum input pulse frequency	Max. 500kpps (differential)/Max. 200kpps (open collector)								
	Command pulse multiplication (electronic gear: A/B)	A, B-1~4096 1/50<A/B<50/1 (Parameter setting)								
	Position complete band	1~4096 pulses (Parameter setting)								
I/O signal power supply	DC24V±20% 0.8A (Supplied externally)									
Electromagnetic brake power supply	DC24V±20% 1A (Max.) (Supplied externally)									
Standard I/Os	9 dedicated inputs/12 dedicated outputs									
Serial communication function	RS232 (For dedicated PC software)									
Protective functions	Motor overvoltage, motor overcurrent, motor overload, driver temperature error, encoder error, etc.									
Operating temperature/humidity	Temperature: 0~40°C, humidity: 85%RH or less									
Operating environment	Not subject to corrosive gases or significant dust.									
Vibration resistance	4.9m/s <sup>2</sup>									
Weight	1.2kg									
Accessory	DI/DO plug, shell									

10 External Dimensions

Controller

P-Driver

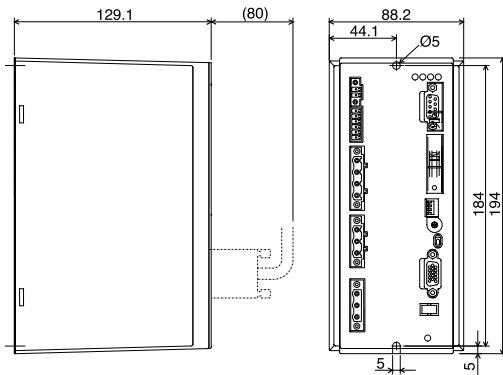

Accessory Pulse Converter (AK-04)

Description: Pulse converter (Model AK-04) + I/O e-CON connector  
Use the pulse converter when the pulse output for the host controller is open-collector specification.

The converter is used to convert the command pulse to differential mode when the host controller is open-collector specification. Converting to differential mode enhances the noise resistance.

Output is 2-phase worth of line-driver 26C31 equivalent of differential output.

I/O connector is the field-wiring ready, easy e-CON connector.

Standard specification

- Input power supply : DC24V±10% (MAX50mA)
- Pulse input : Open-collector (collector current MAX12mA)
- Input frequency : 200kHz or less
- Pulse output : 26C31 equivalent differential output (MAX10mA)
- External dimensions : See the dimension to the right (without cable connector)
- Weight : 10g or less (without cable connector)
- Accessories : e-CON I/O connector  
3M 37104-3122-000FL  
(Applicable electric wires: AWG No.24~26, 0.14~0.3mm<sup>2</sup> or less)  
Final external dimension Ø1.0~1.2mm)

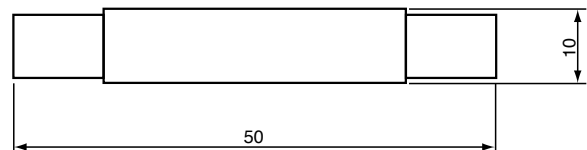
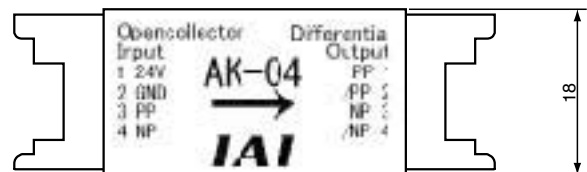

**11 Name of Each Part**

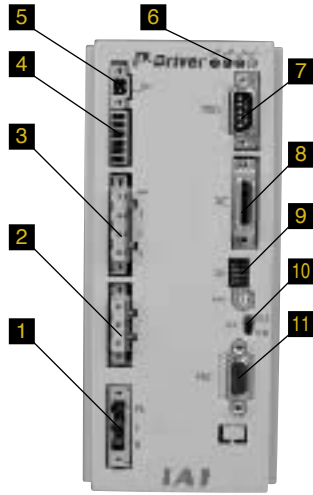

**1 Main power input connector**

Connect the power supply.

**2 Regeneration resistor unit connector**

Connect a regeneration resistor unit (optional).

**3 Motor cable connector**

Connect the actuator's motor cable.

**4 Actuator-sensor input connector**

Connect the actuator's LS, CREEP or OT sensor cable, etc. (optional).

**5 Power input connector for electromagnetic brake**

Connect the power supply for electromagnetic brake. (The electromagnetic brake requires an external power supply.)

**6 Status indicators (LEDs)**

These LEDs are used to monitor the operating condition of the controller.

**7 Communication connector**

Connect the PC software cable.

**8 I/O signal connector**

Connect the control I/O signals.

**9 System setting switch**

A switch for encoder voltage switching and remote update. (The rotary switch is used by IAI for adjustment.)

**10 Brake release switch**

A switch for forcibly releasing the brake.

**11 Encoder cable connector**

Connect the actuator's encoder cable.

**12 Options**

**PC Software**

**Model** PDR-101-MW

**Description**

Floppy disk, PC connection cable (1.5m) (cable model: CB-ST-SIO015)

Use this software to set P-Driver parameters, perform jogging during debugging operation, monitor various signals, and so on.

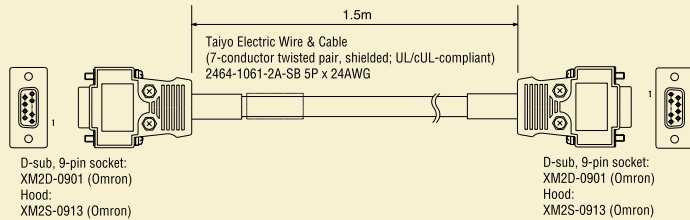

**Wiring Diagram**

Controller end XM2D-0901				PC end XM2D-0901			
Wire	Color	Signal No.		No. Signal	Color	Wire	
AWG24 x 7 conductors	Orange with black dot	RD 2		2	TXD Orange with black dot	AWG24 x 7 conductors	
	Orange with red dot	SD 3		3	RXD Orange with red dot		
	Vinyl wire	ER 4		4	DTR Vinyl wire		
	Yellow with black dot (Shorted)	SG 5		5	SG Yellow with black dot		
	(Shorted)	DR 6		6	DSR (Shorted)		
	Vinyl wire (Shorted)	RS 7		7	RTS Vinyl wire		
	(Shorted)	CS 8		8	CTS (Shorted)		
			9	9			

**External I/O Cable**

**Model** CB-PD-PIOS020

**Description**

Plug + shell + shielded cable (2m) (no connector)

Use this cable for connection with a pulse output device.

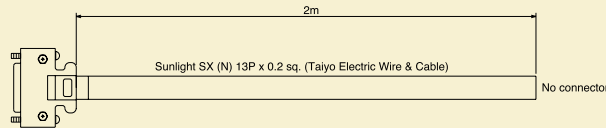

Plug: 10126-3000VE (Sumitomo 3M)  
Shell: 10326-52A0-008 (Sumitomo 3M)

**Wiring Diagram**

Note 1: Twisted pair

10126-3000VE				No-connector end			
Wire	Color	Signal	No.				
	Black	COM-A	1		Black		
	White/Black	COM-A	2		Black/Black		
	Red	SRDY	3		Red		
	White/Red	RUN	4		White/Red		
	Green	INP	5		Green		
	White/Green	DRGR	6		White/Green		
	Yellow	TLR	7		Yellow		
	White/Yellow	ALM	8		White/Yellow		
	Brown	SON	9		Brown		
	White/Brown	BES	10		White/Brown		
	Blue	ORGC	11		Blue		
	White/Blue	TL	12		White/Blue		
	Gray	CSTP	13		Gray		
	White/Gray	COM-B	14		White/Gray		
	Orange	NP	15		Orange		
	White/Orange	/NP	16		White/Orange		
	Purple	PP	17		Purple		
	White/Purple	/PP	18		White/Purple		
	Light Green	AFB	19		Light Green		
	White/Light Green	/AFB	20		White/Light Green		
	Pink	BFB	21		Pink		
	White/Pink	/BFB	22		White/Pink		
	Light Blue	ZFB	23		Light Blue		
	White/Light Blue	/ZFB	24		White/Light Blue		
	White	GND	25		White		
	Black/White	GND	26		Black/White		

0.2 sq. soldered

Connect the shield wire to a cable clamp.

Note 1: Twisted pair

Shielded wire

**Regeneration Unit**

**Model** REU-1

**Description**

This unit converts to heat the regenerative current generated when the motor decelerates. A regeneration resistor is provided inside the controller, but its capacity may not be sufficient when a large load is applied to the vertical axis. In this case, this optional unit is required. (Refer to the table below.)

**Specification**

Item	Specification
Dimensions	W34mm x H195mm x D126mm
Weight	0.9kg
Built-in regeneration resistor	220Ω 80W
Accessory	Controller link cable (model: CB-ST-REU010), 1m

**Installation Standards**

Motor output	Horizontal use	Vertical use
0~150W		Not required.
200~600W	Not required.	1 unit is required.
750W		2 units are required.

\* The above are reference settings assuming the rated conditions (load capacity, speed and acceleration).

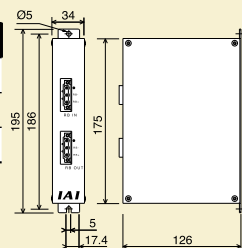

## 9 Service Parts

### Motor Cable (Single-Axis Robot Connection)

Model **CB-X-MA**    \* Indicate the desired cable length (L) of up to 30 m in  (e.g., 080 = 8 m).

Compatible actuators: DS/DSCR/ISP/IS/ISD/IF/FS/SS/SSCR/ISPDCR/ISDCR/ISDCR-ESD/RS

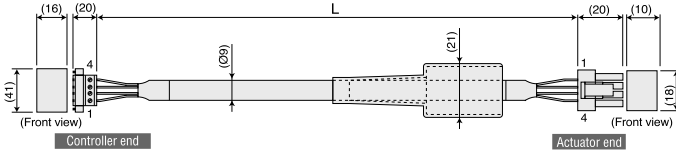

Wire	Color	Signal	No.	No.	Signal	Color	Wire
0.75 sq	Green	PE	1	1	U	Red	0.75 sq (Crimp)
	Red	U	2	2	V	White	
	White	V	3	3	W	Black	
	Black	W	4	4	PE	Green	

### Motor Cable (Robo Cylinder Connection)

Model **CB-RCC-MA**    \* Indicate the desired cable length (L) of up to 30 m in  (e.g., 080 = 8 m).

Compatible actuators: RCS-SS/SM/SSR/SMR/RA55/RB7530/RB7535/F55/G20/R10/R20/R30

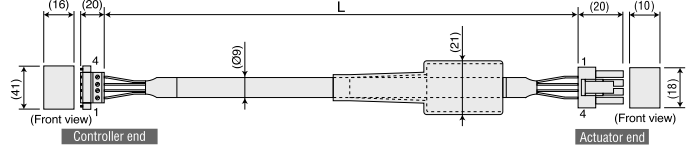

Wire	Color	Signal	No.	No.	Signal	Color	Wire
0.75 sq	Green	PE	1	1	U	Red	0.75 sq (Crimp)
	Red	U	2	2	V	White	
	White	V	3	3	W	Black	
	Black	W	4	4	PE	Green	

### Encoder Cable (Single-Axis Robot Connection)

Model **CB-X-PA**    \* Indicate the desired cable length (L) of up to 30 m in  (e.g., 080 = 8 m).

Compatible actuators: DS/DSCR/ISP/IS/ISD/IF/FS/SS/SSCR/ISPDCR/ISDCR/ISDCR-ESD/RS

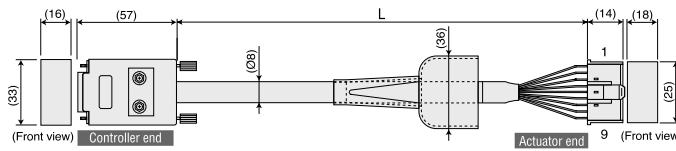

Wire	Color	Signal	No.	No.	Signal	Color	Wire
0.15 sq (Crimp)	-	-	1	1	BAT+	Black	0.15 sq (Crimp)
	-	-	2	2	BAT-	Yellow	
	-	-	3	3	SD	Blue	
	-	-	4	4	SD	Orange	
	-	-	5	5	VCC	Green	
	-	-	6	6	GND	Brown	
	Blue	SD	7	7	-	-	
	Orange	SD	8	8	-	-	
	Black	BAT+	9	9	FG	Ground	
	Yellow	BAT-	10	10	SD	Blue	
	Green	VCC	11	11	SD	Orange	
	Brown	GND	12	12	BAT+	Black	
	Gray	BK-	13	13	BAT-	Yellow	
	Red	BK+	14	14	VCC	Green	
	-	-	15	15	GND	Brown	

Connect the shielded wire to the hood using a clamp.

Ground wire and shielded wire, braided

### Encoder Cable (Robo Cylinder Connection)

Model **CB-RCBC-PA**    \* Indicate the desired cable length (L) of up to 30 m in  (e.g., 080 = 8 m).

Compatible actuators: RCS-SS/SM/SSR/SMR/RA55/RB7530/RB7535/F55/G20/R10/R20/R30

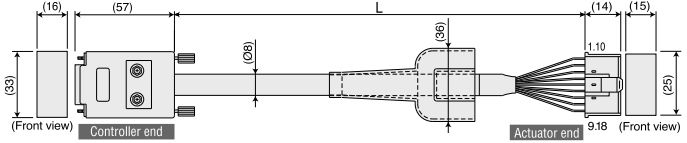

Wire	Color	Signal	No.	No.	Signal	Color	Wire
0.15 sq (Crimp)	Pink	A/U	1	1	A/U	Pink	0.15 sq (Crimp)
	Purple	A/U	2	2	A/U	Purple	
	White	B/V	3	3	B/V	White	
	Blue/Red	B/V	4	4	B/V	Blue/Red	
	Orange/White	Z/W	5	5	Z/W	Orange/White	
	Green/White	Z/W	6	6	Z/W	Green/White	
	Blue	SD	7	7	-	-	
	Orange	SD	8	8	-	-	
	Black	BAT+	9	9	FG	Ground	
	Yellow	BAT-	10	10	SD	Blue	
	Green	VCC	11	11	SD	Orange	
	Brown	GND	12	12	BAT+	Black	
	Gray	BK-	13	13	BAT-	Yellow	
	Red	BK+	14	14	VCC	Green	
	-	-	15	15	GND	Brown	
	-	-	16	16	-	-	
	-	-	17	17	BK-	Gray	
	-	-	18	18	BK+	Red	

Connect the shielded wire to the hood using a clamp.

Ground wire and shielded wire, braided

### Limit Switch Cable (Single-Axis Robot/Robo Rotary Connection)

Model **CB-X-LC**

Compatible actuators: ISP/IS/IF/ISPDCR/RS/R10/R20/R30

\* Indicate the desired cable length (L) of up to 30 m in  (e.g., 080 = 8 m).

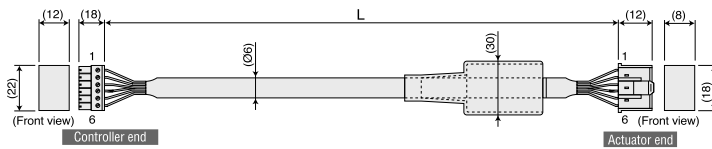

Wire	Color	Signal	No.	No.	Signal	Color	Wire
AWG24	Light Blue	24VOUT	6	1	24VOUT	Light Blue	AWG24 (Crimp)
	Pink	N	5	2	N	Pink	
	Grass	LS	4	3	LS	Grass	
	Orange	CREEP	3	4	CREEP	Orange	
	Gray	OT	2	5	OT	Gray	
	18Light Blue	RSV	1	6	RSV	18Light Blue	

Note) "1B" indicates one black dot mark.

# X-SEL

High-Function Multi-Axes Controller

Operating method programs	Program operation
Number of storable programs	64 programs (6000 steps)
Number of storable positions	3000 positions selectable
Supply voltage	AC100V/200V, selectable

www.actuator.ru тел.:(495) 662-87-56, e-mail: iai@actuator.ru



## 1 Features

### 1 All-in-One Controller Featuring a Newly Developed, Fully Programmable Digital Servo Driver

The driver is equipped with a newly developed, fully programmable digital servo driver supporting a 17-bit serial encoder.

Acceleration/deceleration performance, which is significantly higher than the conventional model (E/G type), reduces tact time.

This all-in-one controller with a built-in driver requires no driver connection, making installation easier.



### 2 Easy Maintenance

All boards can be replaced simply by removing the front panel. The X-SEL ensures prompt, thorough maintenance and service.



### 3 Enhanced Safety Function Backed by CE Mark

The X-SEL controller system protects your equipment with various RAS functions.

Safety is enhanced by a function that cuts off the motor drive power upon an emergency stop or error, a noise elimination feature, etc.

We offer models conforming to the "CE Mark" international safety standard. \*

\* Please contact IAI if you require a CE-compliant specification.



#### 4 Greater Operating Efficiency with Support for Absolute Encoder

The X-SEL supports a 17-bit absolute encoder for rotation data backup, so homing is no longer required when starting your equipment or upon reset following an emergency stop. The X-SEL saves setup time in the morning or reset time in operations requiring frequent stops, thereby improving efficiency.

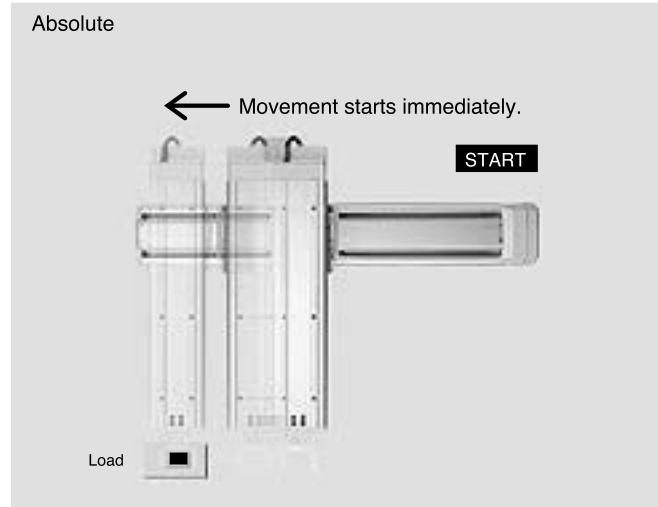
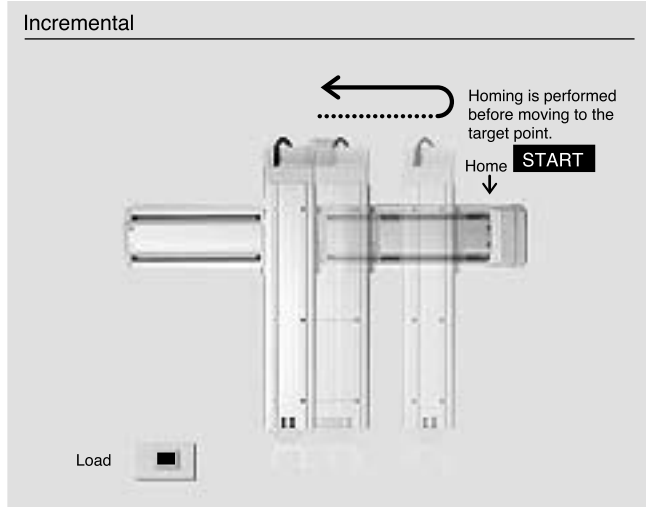

#### 5 Significantly Higher Trace Accuracy

The higher processing speed of the X-SEL controller facilitates a significant improvement in trace accuracy. The speed of path and arc movement has also increased, allowing for faster, more accurate coating operation.

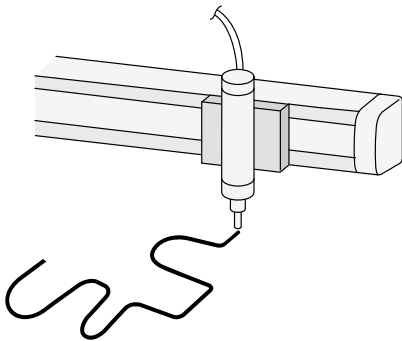

#### 6 Synchronized Operation

The operations of two actuators can be synchronized, allowing for the transfer of load weighing more than the load capacity of a single axis. The synchronized operation function is also useful when a gantry-type model is used with an extended Y-axis. (Certain conditions apply, so please consult with IAI.)

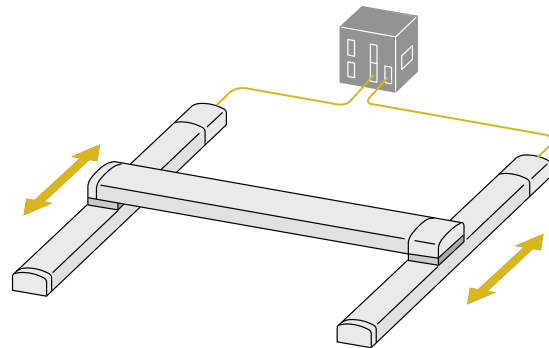

#### 7 Zone Signal

The zone signal function lets you set a desired range (zone) between the stroke limits and cause a signal to be output when the slider enters the specified range. Use this function to provide an interlock, or to synchronize operation, with peripheral equipment. A maximum of four ranges (zones) can be set.

##### ■ Zone Signal

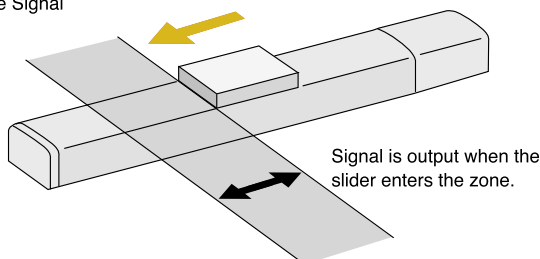

##### ■ Zone Signal Output

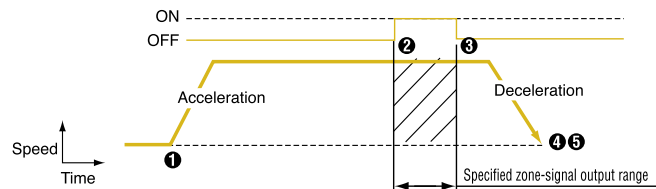

##### ■ Zone Operation

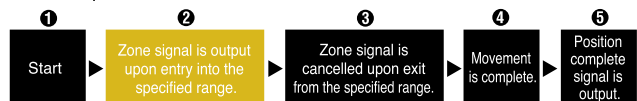

### 8 Push & Hold Operation

The slider can be held in position while pressing against the load, as in similar operations achieved with an air cylinder. This function lets the user easily handle various operations such as applying pressure, clamping and press-fitting works.

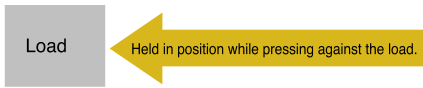

The presence/absence of load is detected by setting the controller in such a way that a signal will be output upon contact with a load.

#### Example of Push & Hold Operation

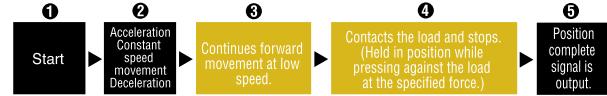
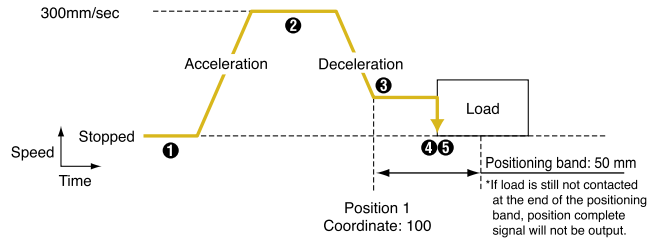

### 9 Significantly Larger Program Data Capacity

6000 programmable steps (largest in its class)  
3000 position points  
Additionally, up to 16 tasks can be executed simultaneously, easily accommodating complex controls and multi-variety work processes.

### 11 Many New Program Commands E/G Type 111 Commands → X-SEL 183 Commands

Many new commands have been added to the Super SEL language, which is known for its ability to generate complex control programs with ease.

#### Examples of Additional Commands

- Palletizing command
- Arch motion command
- Spline command, and many more

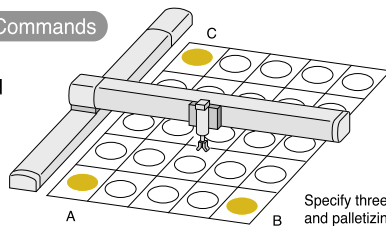

Specify three points (A, B and C) and desired counts, and palletizing points will be set automatically.

### 10 Supporting Pseudo-Ladder Task

Ladder tasks, similar to those generated by a PLC, can be constructed in a program (ladder mnemonic). Since the extended conditions of AND and OR blocks are supported not only in ladder tasks but in all programs as well, so that even complex conditions are handled easily.

### 12 Variable Extension and Symbol Definition

The number of variables that can be used in a program has been doubled from 100 to 200.

Additionally, variables, I/O ports, flags and points can now be assigned symbols (names), making it much easier to review the program.

### 13 Supporting Various Field Networks

The X-SEL supports leading field networks such as DeviceNet, CC-Link, ProfiBus and Ethernet.

(Note) DeviceNet is a registered trademark of ODVA.  
CC-Link is a registered trademark of Mitsubishi Electric Corporation.

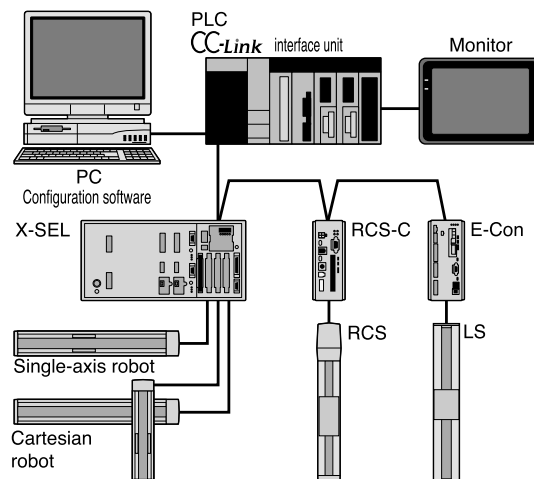
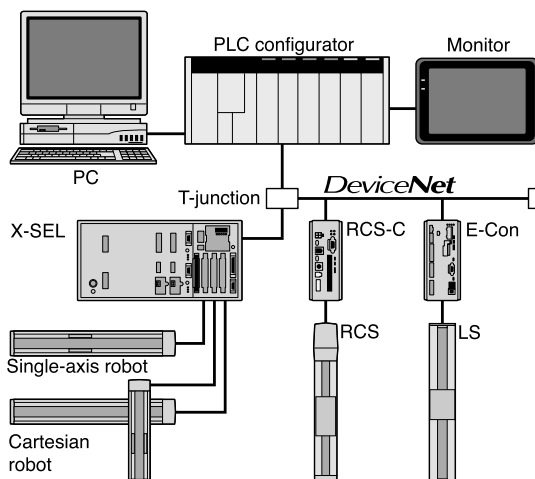

2 Features

662-87-56, e-mail: iai@actuator.ru

**XSEL - K - 3 - 400A - 200ICL - 60IBL - N1 - EEE - 2 - 2**

① ② ③ ④ (Axis 1) ④ (Axis 2) ④ (Axis 3) ⑤ ⑥ ⑦ ⑧

① Series	② Controller type	③ Number of axes	④ Axis 1 to Axis 4 details						⑤ Standard I/O details	⑥ Expansion I/O slots (Note 1)			⑦ I/O flat cable length (Note 2)	⑧ Supply voltage
			Motor output	Encoder type	Brake	Creep	Home sensor (LS)	Synchronization designation		Slot 1	Slot 2	Slot 3		
XSEL	J (Compact type) K (General-purpose type) KE (CE-compliant) KT (Global specification) KET (CE-compliance Global specification)	1 (1 axis) 2 (2 axes) 3 (3 axes) 4 (4 axes)	20 (20W) 30D (30W for DS) 30R (RS for 30W)	I (Incremental) A (Absolute)	Not specified (Without brake) B (With brake)	Not specified (Without creep sensor) C (With creep sensor)	Not specified (Without home sensor) L (With home sensor)	Not specified (No synchronization) M (Master-axis designation) S (Slave-axis designation)	N1 N3 (Note 3) P1 P3 (Note 3) DV CC PR ET	E (Not used) C (Note 4) N1 N2 N3 (Note 4) P1 P2 P3 (Note 4) SA (Note 4) SB (Note 4) SC (Note 4)	E (Not used) C (Note 4) N1 N2 N3 (Note 4) P1 P2 P3 (Note 4) SA (Note 4) SB (Note 4) SC (Note 4)	E (Not used) C (Note 4) N1 N2 N3 (Note 4) P1 P2 P3 (Note 4) SA (Note 4) SB (Note 4) SC (Note 4)	2:2m (Standard) 3:3m 5:5m 0: None	1:100V 2:200V
			60 (60W)											
			100 (100W)											
			150 (150W)											
			200 (200W)											
			300 (300W)											
			400 (400W)											
			600 (600W)											
			750 (750W)											

(Note 1) The J-type 1/2-axis models have no expansion slot, so enter EEE. Similarly, the J-type 3/4-axes models have only one expansion slot, so enter □EE. Refer to page 140 for the types of boards that can be installed.  
 (Note 2) The standard I/O, expansion I/O (50-conductor type) and multipoint I/O (100-conductor type) boards come with an I/O flat cable. The standard cable length for standard and expansion I/O boards is 2 m, but you can also specify 3 or 5 m.  
 The maximum cable length is 10 m, but if you need a cable of any length other than 2, 3 or 5 m, enter "0 (None)" here and order an optional I/O flat cable by specifying a length.  
 If you have selected a board other than the standard I/O, expansion I/O and multipoint I/O boards, enter "0 (None)" here.  
 (Note 3) Used exclusively with the J (compact) type. Use an expansion N3 or P3 board for the K (general-purpose) type.  
 (Note 4) Used exclusively with the K (general-purpose) type. C, SA, SB and SC cannot be specified for the J (compact) type.

3 System Configuration Diagram

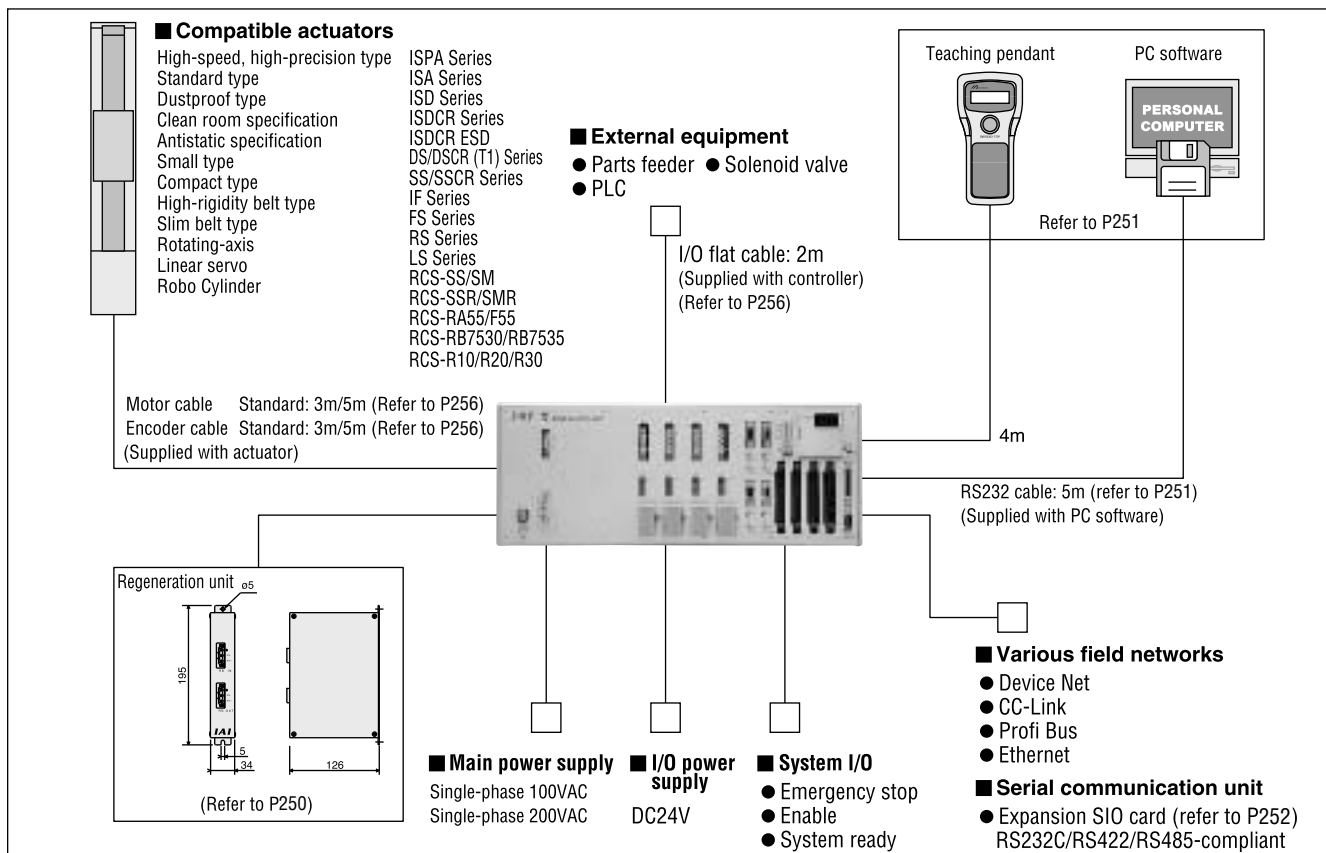

**4 I/O Wiring**

**Input Part** External input specification (NPN specification)

Item	Specification
Input power supply	DC24V ±10%
Input voltage	7mA/point
ON/OFF voltage	ON voltage --- Min DC16.0V OFF voltage --- Max DC5.0V
Insulation method	Photocoupler insulation
External equipment	①No-voltage contact (minimum load, approx. 5VDC/1mA) ②Photoelectric/proximity sensor (NPN type) ③Sequencer transistor output (open-collector type) ④Sequencer contact output (minimum load, approx. 5VDC/1mA)

[Input Circuit]

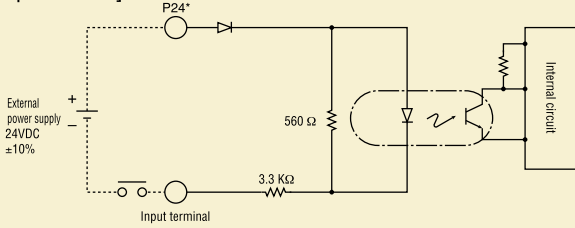

	K (general-purpose) type	J (compact) type
P24	I/O 24-V connector 24VIN	I/O interface pin No. 1

**Output Part** External output specification (NPN specification)

Item	Specification
Load voltage	DC24V
Maximum load current	100mA/point, 400mA Peak (total current)
Leak current	Max. 0.1mA/point
Insulation method	Photocoupler insulation
External equipment	①Miniature relay ②Sequencer input unit

[Output Circuit]

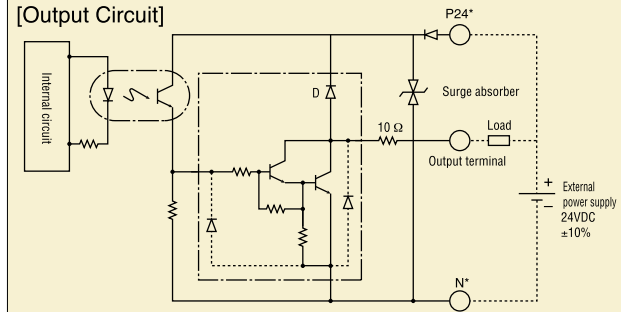

	K (general-purpose) type	J (compact) type
P24	I/O 24-V connector 24VIN	I/O interface pin No. 1
N	I/O 24-V connector 0V	I/O interface pin No. 50

**Input Part** External input specification (PNP specification)

Item	Specification
Input power supply	DC24V ±10%
Input voltage	7mA/point
ON/OFF voltage	ON voltage --- Max DC8V OFF voltage --- Min DC19V
Insulation method	Photocoupler insulation
External equipment	①No-voltage contact (minimum load, approx. 5VDC/1mA) ②Photoelectric/proximity sensor (PNP type) ③Sequencer transistor output (open-collector type) ④Sequencer contact output (minimum load, approx. 5VDC/1mA)

[Input Circuit]

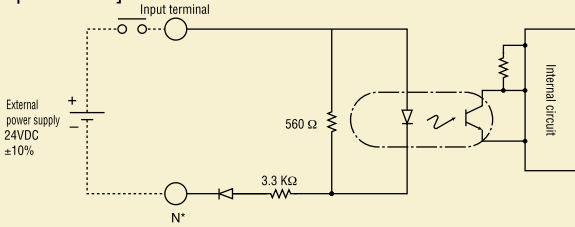

	K (general-purpose) type	J (compact) type
N	I/O 24-V connector 0VIN	I/O interface pin No. 50

**Output Part** External output specification (PNP specification)

Item	Specification
Load voltage	DC24V
Maximum load current	100mA/point 400mA/8 ports Note)
Leak current	Max. 0.1mA/point
Insulation method	Photocoupler insulation
External equipment	①Miniature relay ②Sequencer input unit

Note) The maximum total load current for every eight ports from output port No. 300 is 400 mA. (The maximum sum of load currents for output port No. 300+n through No. 300+n+7 is 400 mA; where n = 0 or a multiple of 8.)

[Output Circuit]

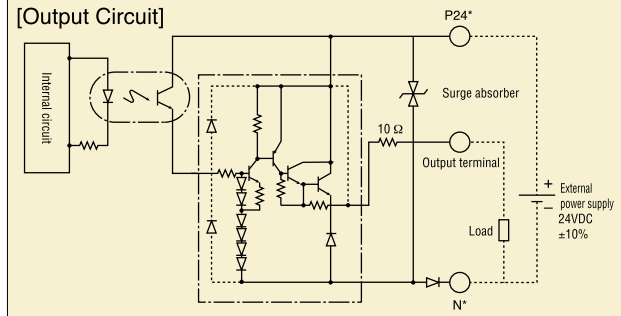

	K (general-purpose) type	J (compact) type
P24	I/O 24-V connector 24VIN	I/O interface pin No. 1
N	I/O 24-V connector 0VIN	I/O interface pin No. 50



5 I/O Signal Table

Standard I/O Signal Table

Pin No.	Category	Port No.	Standard setting
1		—	(J type: Connected to 24V / K type: NC)
2		000	Program start
3		001	General-purpose input
4		002	General-purpose input
5		003	General-purpose input
6		004	General-purpose input
7		005	General-purpose input
8		006	General-purpose input
9		007	Program specification (PRG No. 1)
10		008	Program specification (PRG No. 2)
11		009	Program specification (PRG No. 4)
12		010	Program specification (PRG No. 8)
13		011	Program specification (PRG No. 10)
14		012	Program specification (PRG No. 20)
15		013	Program specification (PRG No. 40)
16		014	General-purpose input
17	Input	015	General-purpose input
18		016	General-purpose input
19		017	General-purpose input
20		018	General-purpose input
21		019	General-purpose input
22		020	General-purpose input
23		021	General-purpose input
24		022	General-purpose input
25		023	General-purpose input
26		024	General-purpose input
27		025	General-purpose input
28		026	General-purpose input
29		027	General-purpose input
30		028	General-purpose input
31		029	General-purpose input
32		030	General-purpose input
33		031	General-purpose input
34		300	Alarm output
35		301	Ready output
36		302	Emergency-stop output
37		303	General-purpose output
38		304	General-purpose output
39		305	General-purpose output
40		306	General-purpose output
41	Output	307	General-purpose output
42		308	General-purpose output
43		309	General-purpose output
44		310	General-purpose output
45		311	General-purpose output
46		312	General-purpose output
47		313	General-purpose output
48		314	General-purpose output
49		315	General-purpose output
50		—	(J type: Connected to 0V / K type: NC)

Expansion I/O Signal Table (IA-103-X-32)

Pin No.	Category	Port No.	Standard setting
1		—	NC
2			General-purpose input
3			General-purpose input
4			General-purpose input
5			General-purpose input
6			General-purpose input
7			General-purpose input
8			General-purpose input
9			General-purpose input
10			General-purpose input
11			General-purpose input
12			General-purpose input
13			General-purpose input
14			General-purpose input
15			General-purpose input
16			General-purpose input
17	Input		General-purpose input
18			General-purpose input
19			General-purpose input
20			General-purpose input
21			General-purpose input
22			General-purpose input
23			General-purpose input
24			General-purpose input
25			General-purpose input
26			General-purpose input
27			General-purpose input
28			General-purpose input
29			General-purpose input
30			General-purpose input
31			General-purpose input
32			General-purpose input
33			General-purpose input
34			General-purpose output
35			General-purpose output
36			General-purpose output
37			General-purpose output
38			General-purpose output
39			General-purpose output
40			General-purpose output
41	Output		General-purpose output
42			General-purpose output
43			General-purpose output
44			General-purpose output
45			General-purpose output
46			General-purpose output
47			General-purpose output
48			General-purpose output
49			General-purpose output
50		—	NC

Expansion I/O Signal Table (IA-103-X-16)

Pin No.	Category	Port No.	Standard setting
1		—	NC
2			General-purpose input
3			General-purpose input
4			General-purpose input
5			General-purpose input
6			General-purpose input
7			General-purpose input
8			General-purpose input
9	Input		General-purpose input
10			General-purpose input
11			General-purpose input
12			General-purpose input
13			General-purpose input
14			General-purpose input
15			General-purpose input
16			General-purpose input
17			General-purpose input
18			General-purpose output
19			General-purpose output
20			General-purpose output
21			General-purpose output
22			General-purpose output
23			General-purpose output
24			General-purpose output
25			General-purpose output
26			General-purpose output
27			General-purpose output
28			General-purpose output
29			General-purpose output
30			General-purpose output
31			General-purpose output
32			General-purpose output
33			General-purpose output
34	Output		General-purpose output
35			General-purpose output
36			General-purpose output
37			General-purpose output
38			General-purpose output
39			General-purpose output
40			General-purpose output
41			General-purpose output
42			General-purpose output
43			General-purpose output
44			General-purpose output
45			General-purpose output
46			General-purpose output
47			General-purpose output
48			General-purpose output
49			General-purpose output
50		—	NC

Multipoint I/O Signal Table (J type: Installed in standard slot)

Cable 1					Cable 2				
Pin No.	Category	Color	Port No.	Standard setting	Pin No.	Category	Color	Port No.	Standard setting
1		Brown-1	—	Externally supplied 24-VDC power For pin Nos. 2 through 25 and 51 through 74	51		Brown-1	300	Alarm output
2	Red-1	000	000	Program start	52		Red-1	301	Ready output
3	Orange-1	001	001	General-purpose input	53	Orange-1	302	Emergency-stop output	
4	Yellow-1	002	002	General-purpose input	54	Yellow-1	303	General-purpose output	
5	Green-1	003	003	General-purpose input	55	Green-1	304	General-purpose output	
6	Blue-1	004	004	General-purpose input	56	Blue-1	305	General-purpose output	
7	Purple-1	005	005	General-purpose input	57	Purple-1	306	General-purpose output	
8	Gray-1	006	006	General-purpose input	58	Gray-1	307	General-purpose output	
9	White-1	007	007	Program specification (PRG No. 1)	59	White-1	308	General-purpose output	
10	Black-1	008	008	Program specification (PRG No. 2)	60	Black-1	309	General-purpose output	
11	Brown-2	009	009	Program specification (PRG No. 4)	61	Brown-2	310	General-purpose output	
12	Red-2	010	010	Program specification (PRG No. 8)	62	Red-2	311	General-purpose output	
13	Orange-2	011	011	Program specification (PRG No. 10)	63	Orange-2	312	General-purpose output	
14	Yellow-2	012	012	Program specification (PRG No. 20)	64	Yellow-2	313	General-purpose output	
15	Green-2	013	013	Program specification (PRG No. 40)	65	Green-2	314	General-purpose output	
16	Blue-2	014	014	General-purpose input	66	Blue-2	315	General-purpose output	
17	Purple-2	015	015	General-purpose input	67	Purple-2	316	General-purpose output	
18	Gray-2	016	016	General-purpose input	68	Gray-2	317	General-purpose output	
19	White-2	017	017	General-purpose input	69	White-2	318	General-purpose output	
20	Black-2	018	018	General-purpose input	70	Black-2	319	General-purpose output	
21	Brown-3	019	019	General-purpose input	71	Brown-3	320	General-purpose output	
22	Red-3	020	020	General-purpose input	72	Red-3	321	General-purpose output	
23	Orange-3	021	021	General-purpose input	73	Orange-3	322	General-purpose output	
24	Yellow-3	022	022	General-purpose input	74	Yellow-3	323	General-purpose output	
25	Green-3	023	023	General-purpose input	75	Green-3	—	Externally supplied 0-VDC power For pin Nos. 2 through 25 and 51 through 74	
26	Blue-3	—	—	Externally supplied 24-VDC power For pin Nos. 27 through 51 and 75 through 99	76	Blue-3	324	General-purpose output	
27	Purple-3	024	024	General-purpose input	77	Purple-3	325	General-purpose output	
28	Gray-3	025	025	General-purpose input	78	Gray-3	326	General-purpose output	
29	White-3	026	026	General-purpose input	79	White-3	327	General-purpose output	
30	Black-3	027	027	General-purpose input	80	Black-3	328	General-purpose output	
31	Brown-4	028	028	General-purpose input	81	Brown-4	329	General-purpose output	
32	Red-4	029	029	General-purpose input	82	Red-4	330	General-purpose output	
33	Orange-4	030	030	General-purpose input	83	Orange-4	331	General-purpose output	
34	Yellow-4	031	031	General-purpose input	84	Yellow-4	332	General-purpose output	
35	Green-4	032	032	General-purpose input	85	Green-4	333	General-purpose output	
36	Blue-4	033	033	General-purpose input	86	Blue-4	334	General-purpose output	
37	Purple-4	034	034	General-purpose input	87	Purple-4	335	General-purpose output	
38	Gray-4	035	035	General-purpose input	88	Gray-4	336	General-purpose output	
39	White-4	036	036	General-purpose input	89	White-4	337	General-purpose output	
40	Black-4	037	037	General-purpose input	90	Black-4	338	General-purpose output	
41	Brown-5	038	038	General-purpose input	91	Brown-5	339	General-purpose output	
42	Red-5	039	039	General-purpose input	92	Red-5	340	General-purpose output	
43	Orange-5	040	040	General-purpose input	93	Orange-5	341	General-purpose output	
44	Yellow-5	041	041	General-purpose input	94	Yellow-5	342	General-purpose output	
45	Green-5	042	042	General-purpose input	95	Green-5	343	General-purpose output	
46	Blue-5	043	043	General-purpose input	96	Blue-5	344	General-purpose output	
47	Purple-5	044	044	General-purpose input	97	Purple-5	345	General-purpose output	
48	Gray-5	045	045	General-purpose input	98	Gray-5	346	General-purpose output	
49	White-5	046	046	General-purpose input	99	White-5	347	General-purpose output	
50	Black-5	047	047	General-purpose input	100	Black-5	—	Externally supplied 0-VDC power For pin Nos. 27 through 51 and 75 through 99	

Multipoint I/O Signal Table (K type: Installed in expansion slot)

Cable 1					Cable 2				
Pin No.	Category	Color	Port No.	Standard setting	Pin No.	Category	Color	Port No.	Standard setting
1		Brown-1	—	Externally supplied 24-VDC power For pin Nos. 2 through 25 and 51 through 74	51		Brown-1	316	General-purpose output
2	Red-1	032	032	General-purpose input	52	Red-1	317	General-purpose output	
3	Orange-1	033	033	General-purpose input	53	Orange-1	318	General-purpose output	
4	Yellow-1	034	034	General-purpose input	54	Yellow-1	319	General-purpose output	
5	Green-1	035	035	General-purpose input	55	Green-1	320	General-purpose output	
6	Blue-1	036	036	General-purpose input	56	Blue-1	321	General-purpose output	
7	Purple-1	037	037	General-purpose input	57	Purple-1	322	General-purpose output	
8	Gray-1	038	038	General-purpose input	58	Gray-1	323	General-purpose output	
9	White-1	039	039	General-purpose input	59	White-1	324	General-purpose output	
10	Black-1	040	040	General-purpose input	60	Black-1	325	General-purpose output	
11	Brown-2	041	041	General-purpose input	61	Brown-2	326	General-purpose output	
12	Red-2	042	042	General-purpose input	62	Red-2	327	General-purpose output	
13	Orange-2	043	043	General-purpose input	63	Orange-2	328	General-purpose output	
14	Yellow-2	044	044	General-purpose input	64	Yellow-2	329	General-purpose output	
15	Green-2	045	045	General-purpose input	65	Green-2	330	General-purpose output	
16	Blue-2	046	046	General-purpose input	66	Blue-2	331	General-purpose output	
17	Purple-2	047	047	General-purpose input	67	Purple-2	332	General-purpose output	
18	Gray-2	048	048	General-purpose input	68	Gray-2	333	General-purpose output	
19	White-2	049	049	General-purpose input	69	White-2	334	General-purpose output	
20	Black-2	050	050	General-purpose input	70	Black-2	335	General-purpose output	
21	Brown-3	051	051	General-purpose input	71	Brown-3	336	General-purpose output	
22	Red-3	052	052	General-purpose input	72	Red-3	337	General-purpose output	
23	Orange-3	053	053	General-purpose input	73	Orange-3	338	General-purpose output	
24	Yellow-3	054	054	General-purpose input	74	Yellow-3	339	General-purpose output	
25	Green-3	055	055	General-purpose input	75	Green-3	—	Externally supplied 0-VDC power For pin Nos. 2 through 25 and 51 through 74	
26	Blue-3	—	—	Note) (DC24V)	76	Blue-3	340	General-purpose output	
27	Purple-3	056	056	General-purpose input	77	Purple-3	341	General-purpose output	
28	Gray-3	057	057	General-purpose input	78	Gray-3	342	General-purpose output	
29	White-3	058	058	General-purpose input	79	White-3	343	General-purpose output	
30	Black-3	059	059	General-purpose input	80	Black-3	344	General-purpose output	
31	Brown-4	060	060	General-purpose input	81	Brown-4	345	General-purpose output	
32	Red-4	061	061	General-purpose input	82	Red-4	346	General-purpose output	
33	Orange-4	062	062	General-purpose input	83	Orange-4	347	General-purpose output	
34	Yellow-4	063	063	General-purpose input	84	Yellow-4	348	General-purpose output	
35	Green-4	064	064	General-purpose input	85	Green-4	349	General-purpose output	
36	Blue-4	065	065	General-purpose input	86	Blue-4	350	General-purpose output	
37	Purple-4	066	066	General-purpose input	87	Purple-4	351	General-purpose output	
38	Gray-4	067	067	General-purpose input	88	Gray-4	352	General-purpose output	
39	White-4	068	068	General-purpose input	89	White-4	353	General-purpose output	
40	Black-4	069	069	General-purpose input	90	Black-4	354	General-purpose output	
41	Brown-5	0							

**6 Specifications**

Item	Description							
Controller series/type	J (compact) type				K (general-purpose) type/KE (CE-compliant) type			
Compatible actuators	DS/DSCR/SS/ISA/ISPA/ISD/ISDCR/SPDCR/SS/SSCR/IF/FS/RS/RCS(partial)/LS							
Applicable motor output (W)	20/30/60/100/150/200/300/400/600/750							
Number of controlled axis	1 axis	2 axes	3 axes	4 axes	1 axis	2 axes	3 axes	4 axes
Maximum output of connected axis (W)	Max 800 (Supply voltage: 200V) Max 400 (Supply voltage: 100V)				Max 800	Max 1600 (Supply voltage: 200V) Max 800 (Supply voltage: 100V)		
Power supply	100-V specification: Single-phase 100~115VAC 200-V specification: Single-phase 200~230VAC							
Power supply voltage range	±10%							
Power frequency	50Hz/60Hz							
Power capacity	Max 830VA	Max 1690VA	Max 1750VA	Max 830VA	Max 1570VA	Max 2310VA	Max 3050VA	
Position detection method	17-bit incremental encoder (wire-saving type) 17-bit absolute encoder for rotation data backup (wire-saving type) (Control resolution: 14 bits for both encoders)							
Speed setting	1mm/s or more; upper limit determined by the actuator specification							
Acceleration setting	0.01G or more; upper limit determined by the actuator specification							
Program language	Super SEL language							
Number of programs	64 programs							
Number of program steps	6000 steps (total)							
Number of multitask programs	16 programs							
Number of positions	3000 positions							
Data storage device	FLASH ROM + SRAM battery backup							
Data input method	Teaching pendant or PC software							
Standard I/Os	32 points (dedicated inputs + general-purpose inputs) / 16 points (dedicated outputs + general-purpose outputs)							
Expanded I/Os	None	48 points/unit (1 unit can be added)			48 points/unit (Maximum of 3 units can be added)			
Serial communication function	RS232 port (D-sub, 25 pins) is installed as standard.				Standard RS232 port + Expansion SIO board can be installed (optional).			
Other I/Os	System I/O (emergency-stop input, enable input, system ready output)							
Protective functions	Motor overcurrent, overload, motor driver temperature check, overload check, encoder open detection, soft limit over, system error, battery error, etc.							
Operating temperature/humidity	Temperature: 0~40°C, humidity: 30~85%							
Operating environment	Not subject to corrosive gases or significant dust.							
Weight	2.6kg	3.3kg	5.0kg		6.0kg		7.0kg	
Accessory	I/O flat cable							

**7 External Dimensions**

**XSEL-J-1 (Compact, 1 axis)**

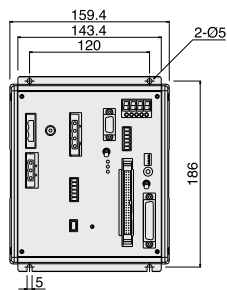

**XSEL-J-2 (Compact, 2 axes)**

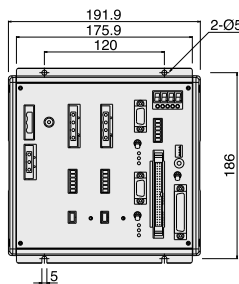

**XSEL-J-3 (Compact, 3 axes)  
XSEL-J-4 (Compact, 4 axes)**

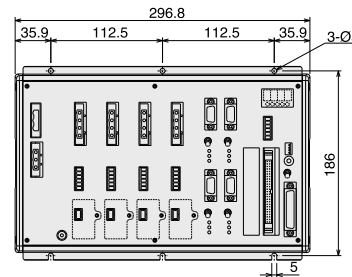

**XSEL-K-1 (General-purpose, 1 axis)  
XSEL-K-2 (General-purpose, 2 axes)**

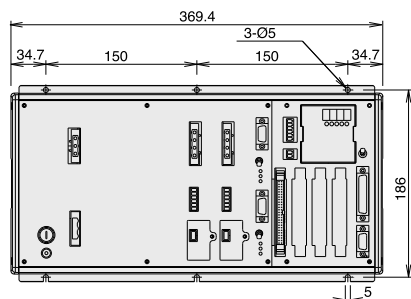

**XSEL-K-3 (General-purpose, 3 axes)  
XSEL-K-4 (General-purpose, 4 axes)**

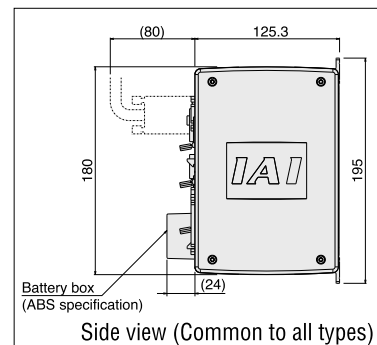
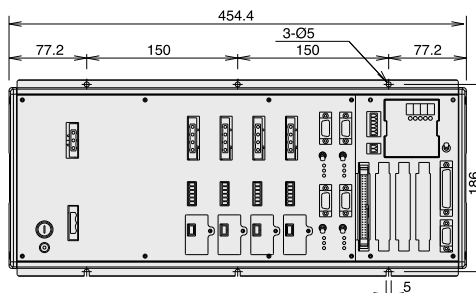

## 8 Name of Each Part

J Type (Compact)

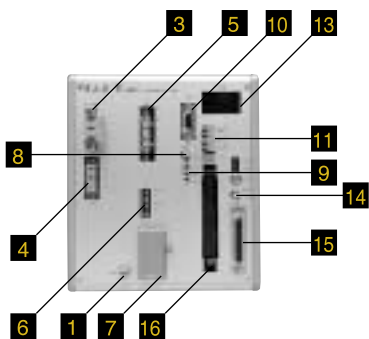

K Type (General-Purpose)

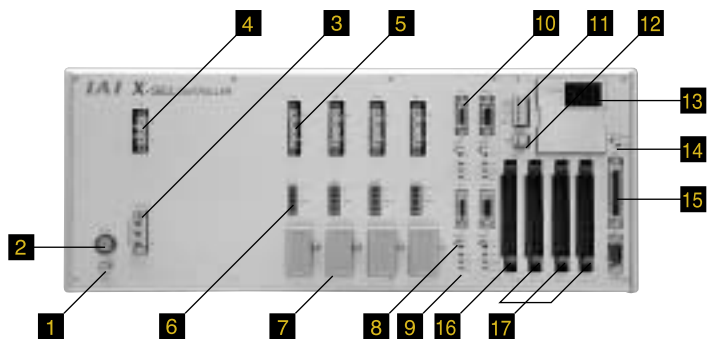

### 1 FG connection terminal

A terminal for connecting the FG of the enclosure.  
The PE of the AC input part is connected to the enclosure inside the controller.

### 2 Fuse holder (K type only)

A half-cut fuse holder for overcurrent protection of the AC input part.

### 3 Main power input connector

A connector for 100/200-VAC single-phase input.  
(A plug is attached on the cable end. Refer to page 139.)

### 4 Regeneration resistor unit connector

A connector for an optional regeneration resistor unit (REU-1), which will be used when the capacity of the built-in regeneration resistor is insufficient in high acceleration/high-load conditions, etc.

### 5 Motor cable connector

A connector for the actuator's motor power cable.

### 6 Actuator sensor input connector

A connector for the axis sensors such as LS, CREEP and OT.

### 7 Absolute data retention battery

A battery unit for encoder backup implemented when an absolute encoder is used. This connector is not used with a non-absolute axis.

### 8 Brake release switch (Brake specification only)

An alternate switch with lock for releasing the axis brake.  
To operate the switch, pull it forward and then move.  
Set the switch to RLS to forcibly release the brake, or set it to NOM to enable automatic control by the controller.

### 9 Axis driver status LEDs

These LEDs are used to monitor the operating status of the driver CPU that controls motor drive. The following three LEDs are available:

Name	Color	Meaning when the LED is lit
ALM	Orange	The driver has detected an error.
SVON	Green	The servo is ON and the motor is being driven.
BATT ALM	Orange	The absolute battery voltage is low.

### 10 Encoder cable connector

A 15-pin, D-sub connector for the actuator's encoder cable.

### 11 System I/O connector

A connector for three I/O signals including two controller-operation control inputs and one equipment status output. (A plug is attached on the cable end. Refer to page 139.)

Name		
EMG	Emergency-stop input	Operation is enabled when this signal is ON. An emergency stop will be actuated when the signal is turned OFF.
ENB	Safety gate input	Operation is enabled when this signal is ON. The servo will turn OFF when the signal is turned OFF.
RDY	System-ready relay output	Status output for this controller. Cascade connection is supported. Ready if shorted. Not ready if open.

### 12 I/O 24-V power connector (K type only)

A connector for externally supplying I/O power when DI/DOs are installed in the I/O part of 16 and 17. (A plug is attached on the cable end. Refer to page 139.)

### 13 Panel window

The 4-digit, 7-segment LED and five LED lamps indicate the equipment status.

### 14 Mode switch

An alternate switch with lock for specifying the controller operation mode.  
To operate the switch, pull it forward and then move.  
Set the switch to MANU to enable the manual operation mode, or set it to AUTO to enable the automatic operation mode.  
Teaching operation can only be performed in the MANU mode. In the MANU mode, automatic operation using external I/Os cannot be performed.

### 15 Teaching connector

A D-sub, 25-pin connector for inputting program positions from the connected teaching pendant or PC.

### 16 Standard I/O slot (Slot 1)

The controller comes standard with a 32-input/16-output PIO board.

### 17 Expansion I/O slots (Slots 2, 3 and 4)

Use these slots to install expansion I/O boards (optional).

**Main Power Input Connector**

This connector is used to connect 100/200 VAC operating power.  
(Cable is provided by the user.)

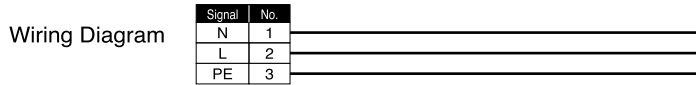
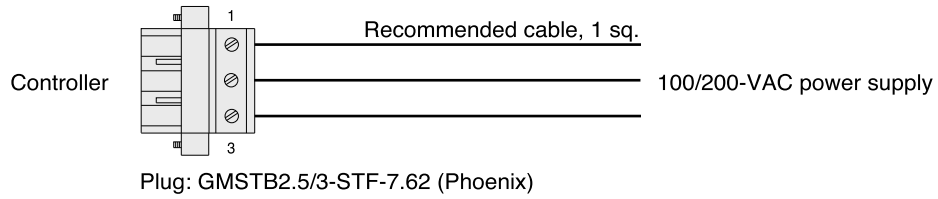

**System I/O Connector**

This connector is used to connect the controller contacts for emergency stop, enable and system ready to a PLC, etc. (Cable is provided by the user.)

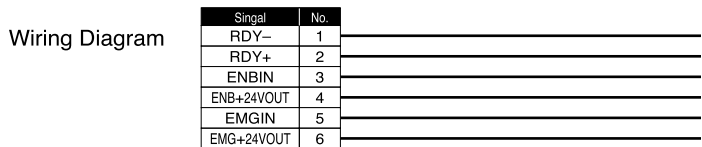
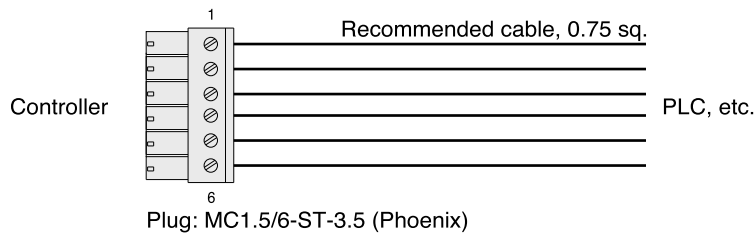

**I/O 24-V Power Connector**

This connector is used to supply 24-V power when the controller's I/Os are used.  
(Cable is provided by the user.)

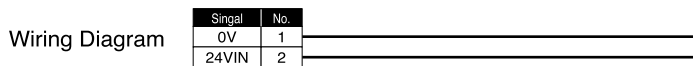
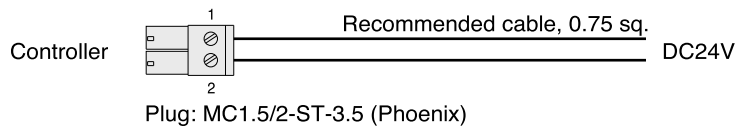

**9 Options**

**X-SEL Controller Options Table**

		Details	General-purpose type		Compact type	
			K	KE	J	
Item			1 to 4 axes	CE-compliant	1 to 2 axes	3 to 4 axes
Teaching Pendant	Standard type		IA-T-X			
	With deadman switch		IA-T-XD			
	ANSI type		IA-T-XA		Cannot be used.	
PC Software	DOS/V version		IA-101-X-MW			
	PC-98 version		IA-101-X-CW			
Expansion I/O Board	PIO Board	Expansion PIO (32 inputs/16 outputs, NPN specification)	IA-103-X-32		Cannot be installed.	IA-103-X-32
		Expansion PIO (32 inputs/16 outputs, PNP specification)	IA-103-X-32-P		Cannot be installed.	IA-103-X-32-P
		Expansion PIO (16 inputs/32 outputs, NPN specification)	IA-103-X-16		Cannot be installed.	IA-103-X-16
		Expansion PIO (16 inputs/32 outputs, PNP specification)	IA-103-X-16-P		Cannot be installed.	IA-103-X-16-P
	SIO Board	Expansion SIO, type A (for RS232C)	IA-105-X-MW-A			
		Expansion SIO, type B (for RS422C)	IA-105-X-MW-B		Cannot be installed.	
		Expansion SIO, type C (for RS485C)	IA-105-X-MW-C			
	Network Board	DeviceNet (256 inputs/256 outputs, for installation in standard slot)	IA-NT-3204-DV		IA-NT-3206-DV	
		CC-Link (256 inputs/256 outputs, for installation in standard slot)	IA-NT-3204-CC256		IA-NT-3206-CC256	
		CC-Link (16 inputs/16 outputs, for installation in expansion slot)	IA-NT-3204-CC16		Cannot be installed.	
		Profibus (256 inputs/256 outputs, for installation in standard slot)	IA-NT-3204-PB		IA-NT-3206-PB	
		Ethernet (Data communication specification, for installation in standard slot)	IA-NT-3204-ET		IA-NT-3206-ET	
	Multipoint I/O Board	Multipoint I/O board (48 inputs/48 outputs, NPN specification)	IA-IO-3204-NP (Note 1)		IA-IO-3205-NP (Note 2)	
		Multipoint I/O board (48 inputs/48 outputs, PNP specification)	IA-IO-3204-PN (Note 1)		IA-IO-3205-PN (Note 2)	
Terminal block for multipoint I/O board (NPN specification)		TU-MA96		Cannot be used.		
Terminal block for multipoint I/O board (PNP specification)		TU-MA96-P		Cannot be used.		
Regeneration Resistor Unit		REU-1				
External Brake Box		IA-110-X-0				
Absolute Data Retention Battery		IA-XAB-BT				

(Note 1) Installed only in an expansion slot

(Note 2) Installed only in the standard slot.

**Regeneration Resistor Unit**

Model **REU-1**

Description

This unit converts to heat the regenerative current generated when the motor decelerates. A regeneration resistor is provided inside the controller, but its capacity may not be sufficient when a large load is applied to the vertical axis. In this case, this optional unit is required. (Refer to the table at bottom right.)

Specification

Item	Specification
Dimensions	W34mm x H195mm x D126mm
Weight	0.9kg
Built-in regeneration resistor	220Ω 80W
Accessory	Controller link cable (model: CB-ST-REU010), 1m

Installation Standards

Determine the required number of units based on the total motor capacity for the connected vertical axes.

Total Z-axis motor capacity	K Type (General-Purpose)	J Type (Compact)
0 ~ 200W	Not required.	Not required.
~ 400W	Not required.	1 unit is required.
~ 600W	1 unit is required.	1 unit is required.
~ 800W	1 unit is required.	2 units are required.
~ 1200W	2 units are required.	—
~ 1600W	To be discussed separately.	—

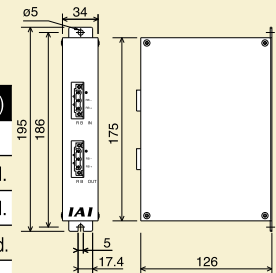

**Absolute Data Retention Battery**

Model **IA-XAB-BT**

Features

This battery is used with an absolute encoder for storing data. Replace the battery when a controller battery alarm is output.

Specification

Integrated with case

Simple Teaching Pendant

Model **IA-T-X** (Standard)

**IA-T-XD** (With deadman switch)

Features A teaching device with program/position input, test operation and monitoring functions. The interactive-type panel ensures easy operation for anyone. The deadman switch specification offering added safety is also available.

Specification

Items	Specification
Operating temperature, humidity	Temperature: 0~40°C, humidity: 85%RH or less
Operating environment	Not subject to corrosive gases or significant dust.
Weight	Approx. 650g
Cable length	4m
Display	20 characters x 4 lines, LCD

Caution  
A product older than Ver. 1.08 cannot be used with the SCARA robot.

Dimensions

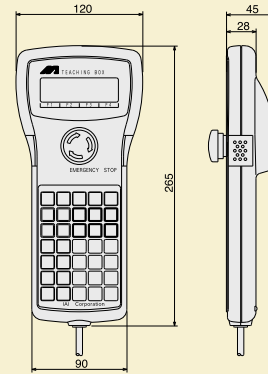

Teaching Pendant Conforming to ANSI/CE Mark Standards (General-Purpose Type Only)

Model **IA-T-XA**

Features This teaching pendant with a three-position enable switch conforms to the ANSI and CE Mark standards. Using the large, interactive LCD screen, even a beginner can teach a robot easily and safely.

Specification

Items	Specification
Operating temperature, humidity	Temperature: 0~40°C, humidity: 30~85%RH or less (non-condensing)
Protection structure	IP54 (excluding cable connector)
Weight	600g or less (excluding cable)
Cable length	5m
Display	32 characters x 8 lines, LCD

Dimensions

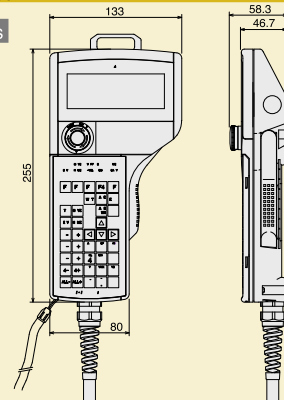

PC Software (Windows Version Only)

Model **IA-101-X-MW** (DOS/V version)  
**IA-101-X-CW** (PC98 version)

Caution  
A product older than Ver. 2.0.0.0 cannot be used with the SCARA robot.

Features A support software with program/position data input, test operation and monitoring functions. It offers significantly improved debugging functions to help reduce the development time for your equipment.

Description  
• Software (floppy disk)  
(Windows 95, 98, NT, 2000 and ME are supported)  
• PC connection cable (5m) + Emergency-stop box (Model: CB-ST-E1MW050-EB)

Dimensions

PC connection cable (Model: CB-ST-E1MW050)

Caution  
If you are ordering a PC connection cable separately for maintenance purposes, specify CB-ST-E1MW050. If you are ordering the cable together with an emergency-stop box, specify CB-ST-E1MW050-EB.

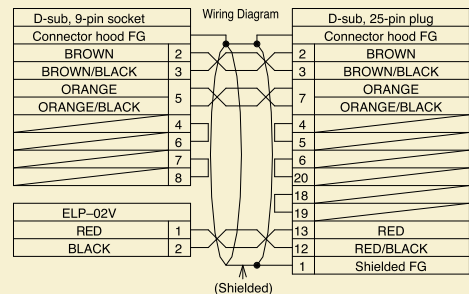
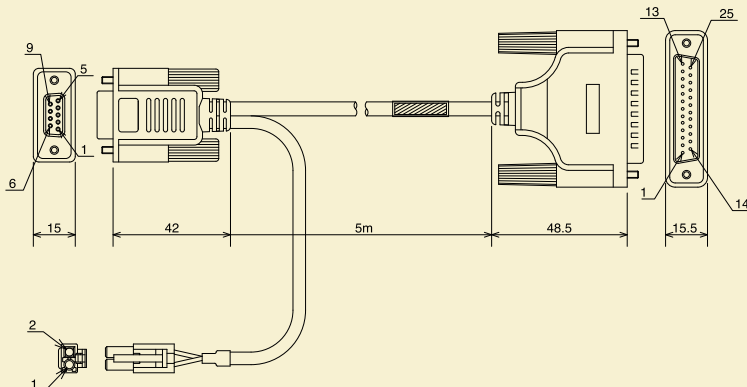



■ Multipoint I/O Board & Terminal Block

A set of board and terminal block used when many PIO points are required for the controller.

System Configuration

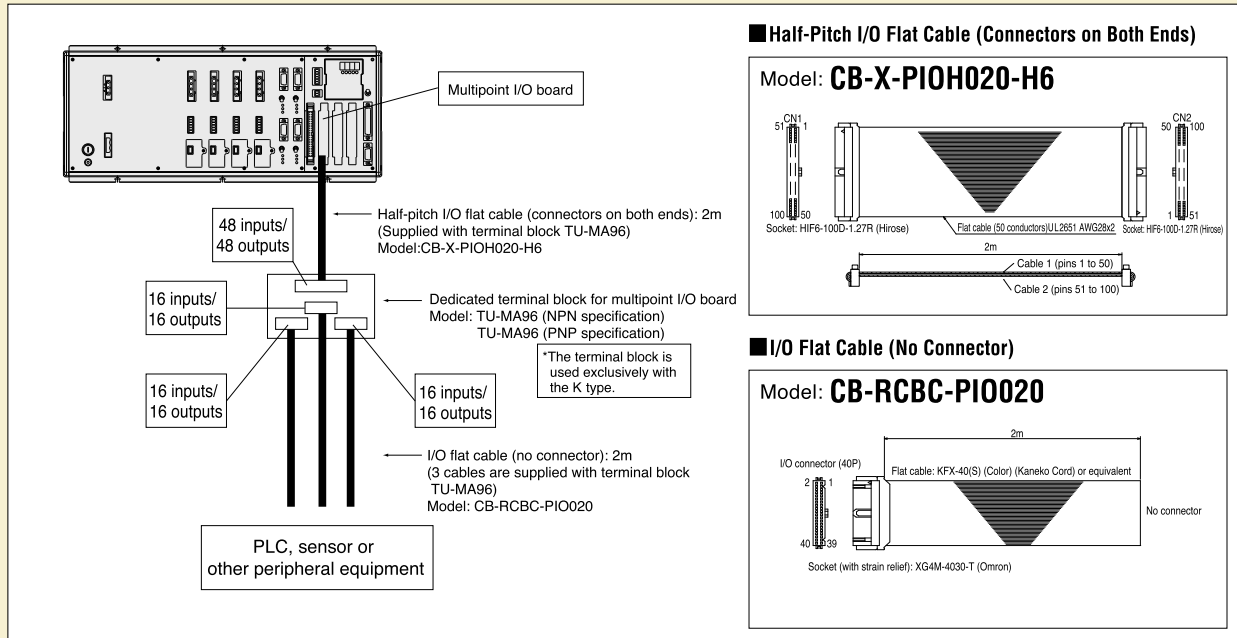

■ Half-Pitch I/O Flat Cable (Connectors on Both Ends)

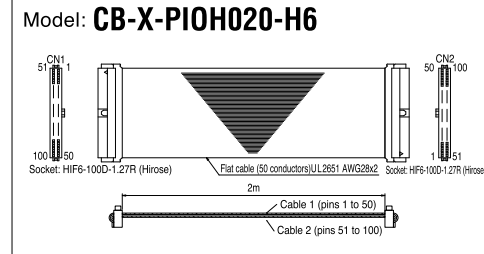

■ I/O Flat Cable (No Connector)

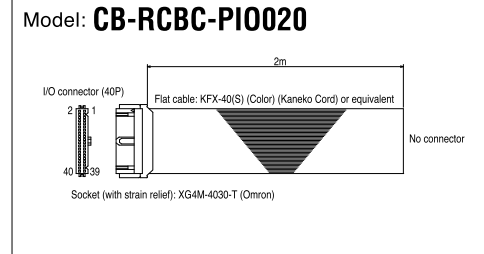

Multipoint I/O Board

**Description** This I/O board uses a half-pitch connector to provide 48 inputs and 48 outputs on a single board. The supplied half-pitch flat cable has thin wires and thus difficult to wire. Use a dedicated terminal block for connection with external equipment.

Description	Multipoint I/O board model	Ordering model (controller model)	Multipoint I/O board slot	Total number of I/O points
48 inputs/48 outputs NPN specification	IA-IO-3205-NP	XSEL-J-□-□-N3-EEE-□-□	Expansion slot	48 inputs/48 outputs
48 inputs/48 outputs PNP specification	IA-IO-3205-PN	XSEL-J-□-□-P3-EEE-□-□	Expansion slot	48 inputs/48 outputs
48 inputs/48 outputs NPN specification	IA-IO-3204-NP	XSEL-K-□-□-N1-N3EE-□-2	Expansion slot 1	80 inputs/64 outputs
		XSEL-K-□-□-N1-N3N3E-□-2	Expansion slot 1,2	128 inputs/112 outputs
		XSEL-K-□-□-N1-N3N3N3-□-2	Expansion slot 1,2,3	176 inputs/160 outputs
48 inputs/48 outputs PNP specification	IA-IO-3204-PN	XSEL-K-c-c-P1-P3EE-c-2	Expansion slot 1	80 inputs/64 outputs
		XSEL-K-c-c-P1-P3P3E-□-2	Expansion slot 1,2	128 inputs/112 outputs
		XSEL-K-□-□-P1-P3P3P3-□-2	Expansion slot 1,2,3	176 inputs/160 outputs

<Dedicated terminal block for multipoint I/O board> **K Type Only**

**Model** **TU-MA96** (NPN specification)  
**TU-MA96-P** (PNP specification)

**Description** A terminal block for wiring a multipoint I/O board. This terminal block not only simplifies wiring, but it also offers the following functions:

1. The built-in transistor buffer circuit ensures output of 500 mA per point (0.8 A per eight points).
2. The power circuit can be divided into six input systems (each comprising eight inputs) and six output systems (each comprising eight outputs).
3. LEDs are provided for checking the power supply for output signal circuit. Six LEDs are provided, each corresponding to one output system (each system comprises eight outputs). The LED will turn off when the power is cut off or a fuse on the board is blown.

**Caution** If you are using a terminal block, be sure to use a multipoint I/O board of NPN specification. (The terminal block has been set to NPN, so a PNP board cannot be used.) This terminal block is used exclusively with the K type. (It cannot be used with the JX type.)

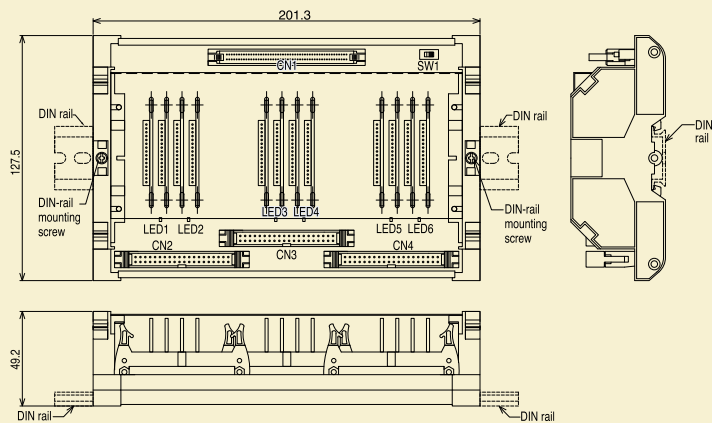



Dedicated Terminal Block for Multipoint I/O Board- Connector Pin Assignment

This connector is used for connection with an external I/O device. One connector can connect 16 DI points and 16 DO points.

External I/O Connector Specification Table

Item					
Applicable connector	XG4A-4031(OMRON) 40-pin, MIL flat connector				
DI	48 points				
DO	48 points				
Connected unit	External I/O device				
Connector name			CN2 connector	CN3 connector	CN4 connector
Pins and assigned inputs	1	Common	Common terminal (COM):	Common terminal (COM):	Common terminal (COM):
	2	Common	For IN00 to IN07	For IN16 to IN23	For IN32 to IN39
	3	General-purpose input	IN00	IN16	IN32
	4	General-purpose input	IN01	IN17	IN33
	5	General-purpose input	IN02	IN18	IN34
	6	General-purpose input	IN03	IN19	IN35
	7	General-purpose input	IN04	IN20	IN36
	8	General-purpose input	IN05	IN21	IN37
	9	General-purpose input	IN06	IN22	IN38
	10	General-purpose input	IN07	IN23	IN39
	11	General-purpose input	IN08	IN24	IN40
	12	General-purpose input	IN09	IN25	IN41
	13	General-purpose input	IN10	IN26	IN42
	14	General-purpose input	IN11	IN27	IN43
	15	General-purpose input	IN12	IN28	IN44
	16	General-purpose input	IN13	IN29	IN45
	17	General-purpose input	IN14	IN30	IN46
	18	General-purpose input	IN15	IN31	IN47
	19	Common	Common terminal (COM):	Common terminal (COM):	Common terminal (COM):
	20	Common	For IN08 to IN15	For IN24 to IN31	For IN40 to IN47
Pins and assigned outputs	21	+24V	External 24-V power input:	External 24-V power input:	External 24-V power input:
	22	0V	For OUT00 to OUT07	For OUT16 to OUT23	For OUT32 to OUT39
	23	General-purpose output	OUT00	OUT16	OUT32
	24	General-purpose output	OUT01	OUT17	OUT33
	25	General-purpose output	OUT02	OUT18	OUT34
	26	General-purpose output	OUT03	OUT19	OUT35
	27	General-purpose output	OUT04	OUT20	OUT36
	28	General-purpose output	OUT05	OUT21	OUT37
	29	General-purpose output	OUT06	OUT22	OUT38
	30	General-purpose output	OUT07	OUT23	OUT39
	31	General-purpose output	OUT08	OUT24	OUT40
	32	General-purpose output	OUT09	OUT25	OUT41
	33	General-purpose output	OUT10	OUT26	OUT42
	34	General-purpose output	OUT11	OUT27	OUT43
	35	General-purpose output	OUT12	OUT28	OUT44
	36	General-purpose output	OUT13	OUT29	OUT45
	37	General-purpose output	OUT14	OUT30	OUT46
	38	General-purpose output	OUT15	OUT31	OUT47
	39	+24V	External 24-V power input:	External 24-V power input:	External 24-V power input:
	40	0V	For OUT08 to OUT15	For OUT24 to OUT31	For OUT40 to OUT47

External Brake Box

Description

This force-release brake box can release the actuator brake even when the controller power is turned off. (Note 1)  
 The brake can be released using the switch on the brake box or by connecting an external switch (supplied with a dedicated cable).  
 When ordering, specify the models and quantities for the brake box and cable. (Up to two axes can be connected to one brake box.)  
 (Note 1) A dedicated 24-V power supply is required for releasing the brake.

System Configuration

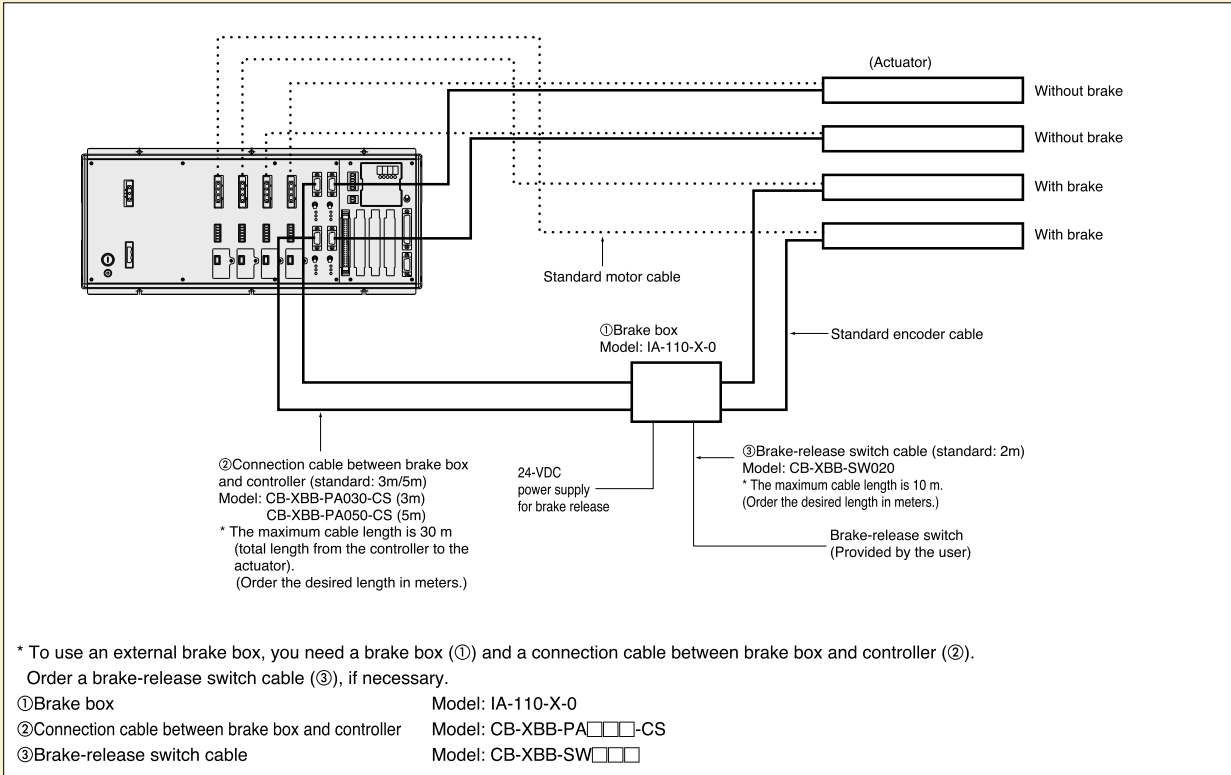

External Dimensions of Brake Box

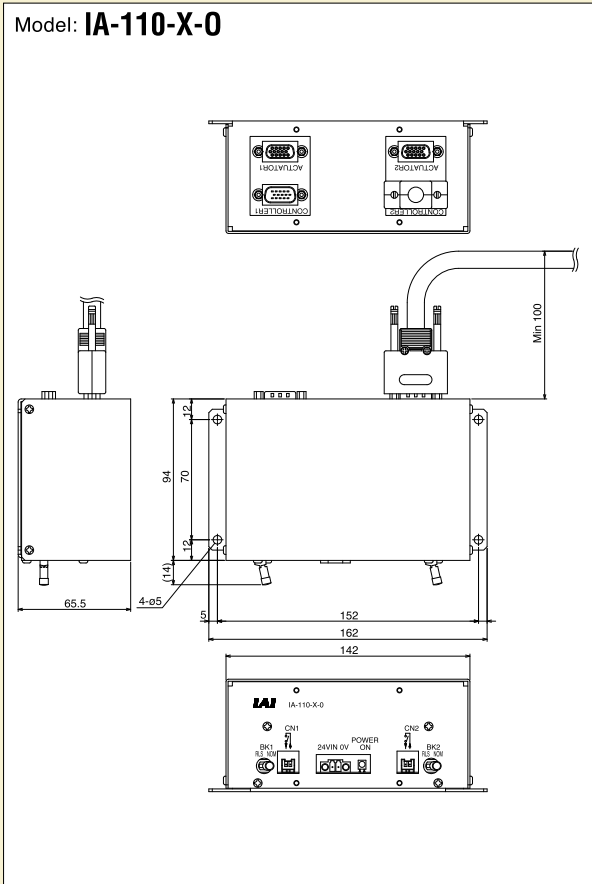

Connection cable between brake box and controller

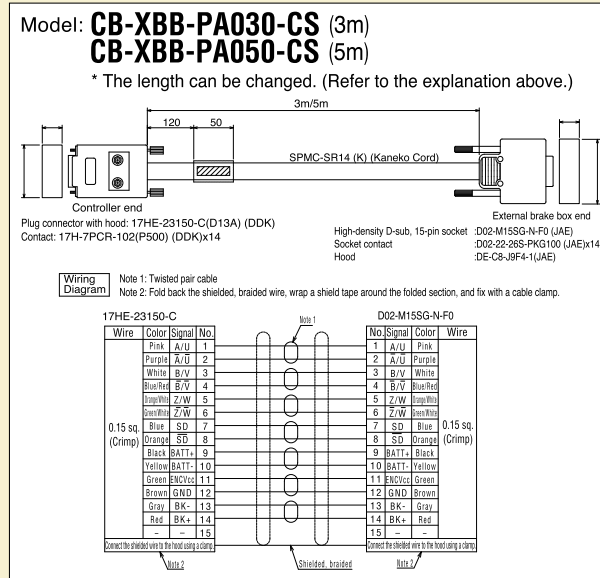

Brake-release switch cable

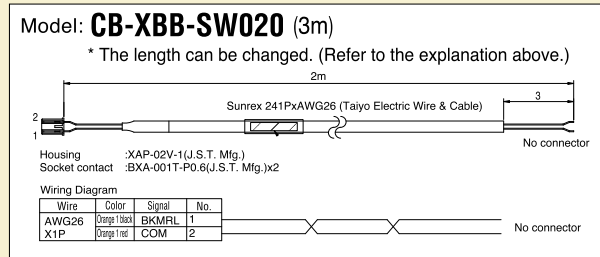

The following cables will be supplied with the actuator and controller you have purchased. If you must replace the original cables or otherwise require additional cables, place an order by referencing the model names specified below.

**Motor Cable (Single-Axis Robot Connection)**

Model **CB-X-MA** □□□

\* Indicate the desired cable length (L) of up to 30 m in □□□ (e.g., 080 = 8 m).

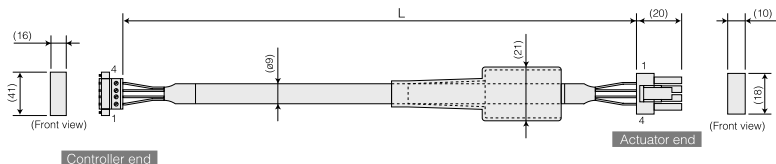

Wire	Color	Signal	No.	No.	Signal	Color	Wire
0.75sq	Green	PE	1	1	U	Red	0.75sq (Crimp)
	Red	U	2	2	V	White	
	White	V	3	3	W	Black	
	Black	W	4	4	PE	Green	

**Encoder Cable (Single-Axis Robot Connection)**

Model **CB-X-PA** □□□

\* Indicate the desired cable length (L) of up to 30 m in □□□ (e.g., 080 = 8 m).

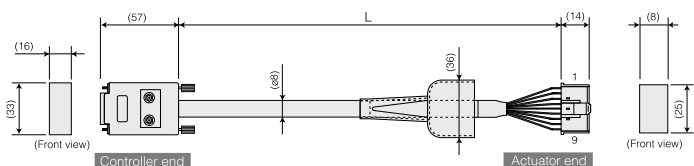

Wire	Color	Signal	No.	No.	Signal	Color	Wire
0.15sq (Crimp)	-	-	1	1	BAT+	Black	0.15sq (Crimp)
	-	-	2	2	BAT-	Yellow	
	-	-	3	3	SD	Blue	
	-	-	4	4	SD	Orange	
	-	-	5	5	VCC	Green	
	-	-	6	6	GND	Brown	
	Blue	SD	7	7	FG	Ground	
	Orange	SD	8	8	BK+	Red	
	Black	BAT+	9	9	-	-	
	Yellow	BAT-	10	10	-	-	
	Green	VCC	11	11	-	-	
	Brown	GND	12	12	-	-	
	Gray	BK-	13	13	-	-	
	Red	BK+	14	14	-	-	
	-	-	15	15	-	-	

Connect the shielded wire to the hood using a clamp. Ground wire and shielded wire, braided.

**Limit Switch Cable (Single-Axis Robot Connection)**

Model **CB-X-LC** □□□

\* Indicate the desired cable length (L) of up to 30 m in □□□ (e.g., 080 = 8 m).

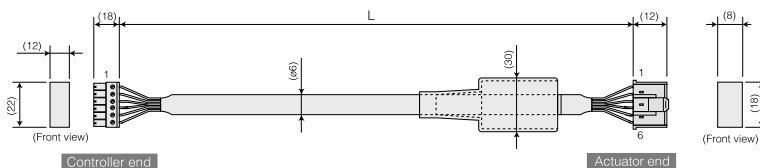

Wire	Color	Signal	No.	No.	Signal	Color	Wire
AWG24	Light Blue	2VOUT	6	1	2VOUT	Light Blue	AWG24 (Crimp)
	Pink	N	5	2	N	Pink	
	Grass	LS	4	3	LS	Grass	
	Pink	CREEP	3	4	CREEP	Pink	
	Gray	OT	2	5	OT	Gray	
	1B/Light Blue	RSV	1	6	RSV	1B/Light Blue	

Note) \*1B\* indicates one black dot mark.

**I/O Flat Cable (X-SEL)**

**I/O Flat Cable (X-SEL)**

Model **CB-X-PIO** □□□

\* Indicate the desired cable length (L) of up to 10 m in □□□ (e.g., 080 = 8 m).

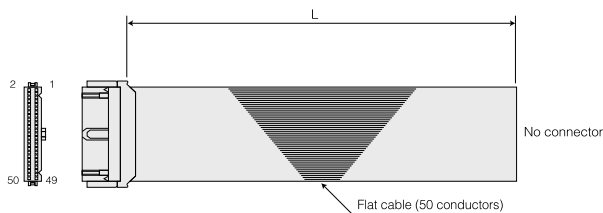

No.	Color	Wire	No.	Color	Wire	No.	Color	Wire
1	Brown1	Flat cable	18	Gray2	Flat cable	35	Green4	Flat cable
2	Red1		19	White2		36	Blue4	
3	Orange1		20	Black2		37	Purple4	
4	Yellow1		21	Brown-3		38	Gray4	
5	Green1		22	Red3		39	White4	
6	Blue1		23	Orange3		40	Black4	
7	Purple1		24	Yellow3		41	Brown-5	
8	Gray1		25	Green3		42	Red5	
9	White1		26	Blue3		43	Orange5	
10	Black1		27	Purple3		44	Yellow5	
11	Brown-2		28	Gray3		45	Green5	
12	Red2		29	White3		46	Blue5	
13	Orange2		30	Black3		47	Purple5	
14	Yellow2		31	Brown-4		48	Gray5	
15	Green2		32	Red4		49	White5	
16	Blue2		33	Orange4		50	Black5	
17	Purple2		34	Yellow4				

# Large Capacity Controller **X-SEL**



# A Compact Yet Powerful Controller with a Maximum Output of 2400 W

A new high-performance controller series capable of controlling six axes

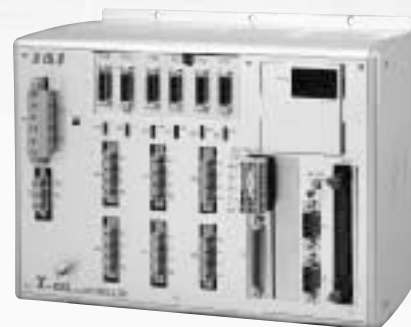

## 1 Maximum output of 2400 W

(Reference: IAI's conventional general-purpose type – 1600 W, compact type – 800 W)

Six 400W single-axis robots or three 750W single-axis robots can be operated simultaneously.

## 2 "Global Specification" corresponding to Safety Category 4

The "Global Specification" provides an external safety circuit, instead of incorporating a drive-power cutoff circuit into the controller. This design ensures correspondence to Safety Category 4 under ISO 13849-1.

## 3 Capable of driving one to six axes

- A maximum of six axes can be operated complementarily using only one controller unit.
- Six axes are operated with a single program, allowing easy programming.

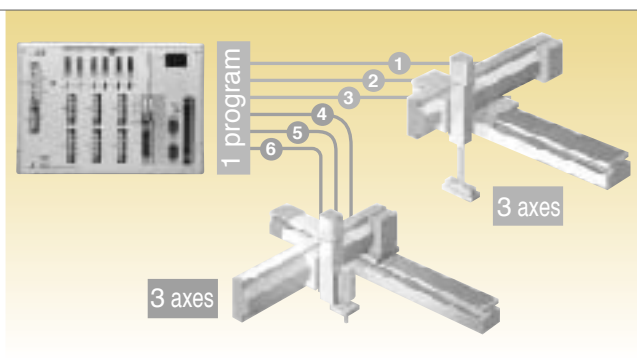

## 4 Compact and high performance

- A slim design of approx. 40% the volume of IAI's conventional controller (X-SEL general-purpose controller)
- Significantly higher speed compared with IAI's conventional controller (the command processing time is nearly half)
- Connectable to DeviceNet, CC-Link, Ethernet and other networks

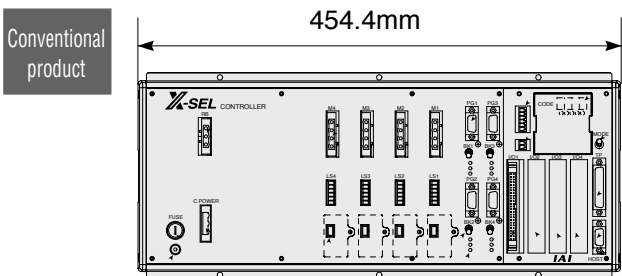

XSEL-K (general-purpose type) 4 axes, 1.6 Kw

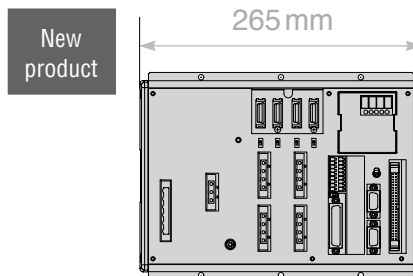

XSEL-P 4 axes, 2.4 Kw

# XSEL - P - 3 - 400AL - 200AL - 60ABL - DV - NI - EEE - 2 - 3







① Series	② Controller type	③ Number of axes	④ Details of axis 1 to axis 6						⑤ Network (dedicated slot)	⑥ Standard I/O (Slot 1)	⑦ Expansion I/O slots			⑧ Flat cable length	⑨ Power-supply voltage
			Motor Output	Encoder type	Brake	Creep	Home Sensor	Synchronization designation			Slot 2	Slot 3	Slot 4		
XSEL	P (Standard) Q (Global)	1 (1 axis)	20 (20W) 30D (30W for DS) 30R (30W for RS)	I (Incremental) A (Absolute)	Not Specified (w/o brake) B (w/ brake)	Not Specified (w/o creep) C (w/ creep)	Not Specified (w/o home sensor) L (w/ home sensor)	Not Specified (No synchronization) M (Master-axis designation) S (Slave-axis designation)	Not Specified (No network) DV DeviceNet 256/256 board CC CC-Link 256/256 board PR ProfiBus 256/256 board ET Ethernet Data communication board	E (Not used)	E (Not used)	E (Not used)	2 : 2 m (Standard) 3 : 3 m 5 : 5 m 0 : None	3: Three-phase 200V	
		2 (2 axes)	60 (60W)							N1	N1	N1			
		3 (3 axes)	100 (100W)							N2	N2	N2			
		4 (4 axes)	150 (150W)							N3	N3	N3			
		5 (5 axes)	200 (200W)							P1	P1	P1			
		6 (6 axes)	300 (300W)							P2	P2	P2			
		400 (400W)	P3	P3	P3										
		600 (600W)	Multipoint I/O PNP 48/48	Multipoint I/O PNP 48/48	Multipoint I/O PNP 48/48	Multipoint I/O PNP 48/48									

**Main Specifications**

	Standard		Global	
	Axis 1 to axis 4	Axis 5 to axis 6	Axis 1 to axis 4	Axis 5 to axis 6
Total output when maximum number of axes are connected	2400W			
Control power input	Single-phase 200/230VAC -15%, +10%			
Motor power input	Three-phase 200/230VAC -10%, +10%			
Power capacity (*1)	MAX 4878VA (600W x 4 axes)	MAX 4998VA (400W x 6 axes)	MAX 4878VA (600W x 4 axes)	MAX 4998VA (400W x 6 axes)
Safety circuit configuration	Redundant design not supported		Redundant design supported	
Drive-power cutoff method	Internal relay cutoff		External safety circuit	
Enable input	Contact-B input (internal power supply)		Contact-B input (external power supply, redundancy)	
Position detection method	Incremental encoder/absolute encoder			
Speed setting (*2)	1 mm/sec ~ 2000 mm/sec			
Acceleration/deceleration setting (*2)	0.01 G ~ 1 G			
Program language	Super SEL language			
Number of program steps	6000 steps (total)			
Number of positions	4000 positions (total)			
Number of programs (multitasking)	64 programs (16 programs)			
Operating temperature/humidity	0~40°C, 10%~95% (non-condensing)			
Weight (*3)	5.2 kg	5.7 kg	4.5 kg	5 kg

\*1 Based on the maximum wattage of each connected axis.  
 \*2 The maximum limit will vary depending on the actuator type.  
 \*3 Including the absolute battery, brake mechanism and expansion I/O box.

**X-SEL Series Product Lineup**

	XSEL-J	XSEL-K	XSEL-KE	XSEL-KT	XSEL-P	XSEL-Q
	Compact type	General-purpose type	CE-compatible type	Global specification (Safety Category 4)	Large-capacity type, standard specification	Large-capacity type, global specification (Safety Category 4)
						
Operating method	Program operation					
Programs	64 programs (6000 steps)					
Number of positions	3000 positions			4000 positions		
Maximum number of connectable axes	4 axes			6 axes		
Maximum output	0.8 kw	1.6 kw	1.6 kw	1.6 kw	2.4 kw	2.4 kw
Power supply	Single-phase 100VAC / Single-phase 200VAC				Three-phase 200VAC	Three-phase 200VAC
Safety category	B			Corresponds to Category 4	B	Corresponds to Category 4
Safety standard	—		CE	ANSI (*1)	CE	CE, ANSI (*1)

\*1 To support ANSI, the ANSI-compatible teaching pendant (IA-T-XA) is required.

• **System Configuration**

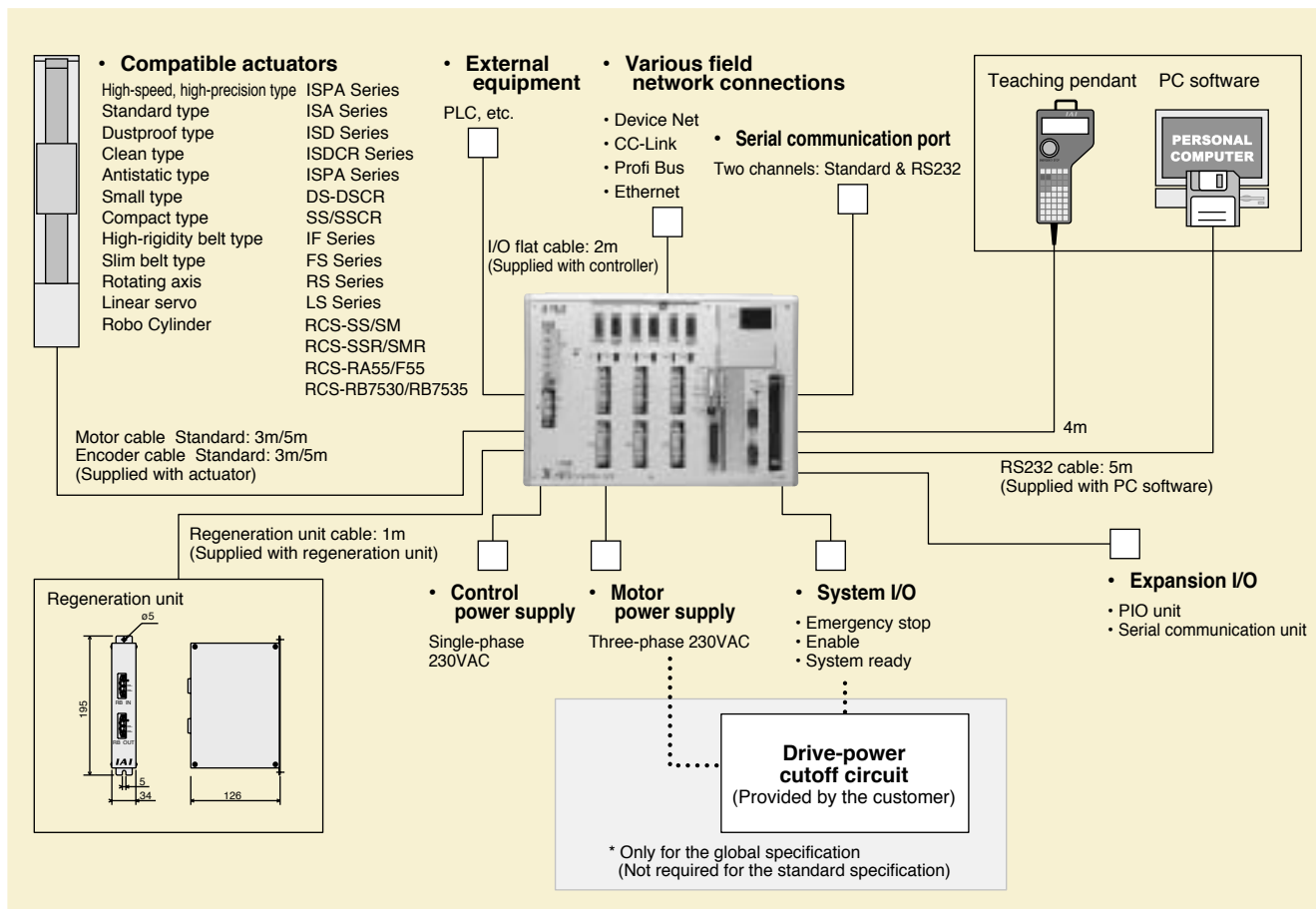

• **External Dimensions**

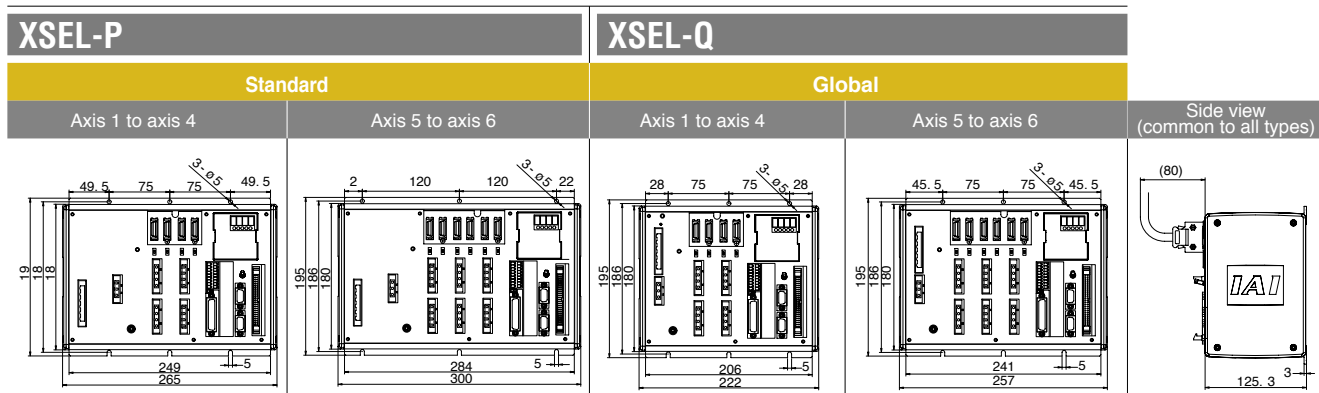

In the case of the following specifications, the overall width will follow the table below (mounting hole positions are the same).

	Standard		Global	
	Axis 1 to axis 4	Axis 5 to axis 6	Axis 1 to axis 4	Axis 5 to axis 6
With absolute battery/brake unit *1	285	340	242	297
With I/O expansion base *2	338	373	295	330
With I/O expansion base + absolute battery/brake unit *3	358	413	315	370

\*1 With absolute battery or brake, or absolute battery with brake.

\*2 When expansion I/Os are added.

\*3 With absolute battery or brake, or absolute battery with brake, plus expansion I/Os.